

# EDMA<sup>®</sup>

UN OUTIL D'AVANCE



GENERAL  
CATALOGUE  
**2024**

French  **MANUFACTURER**  
since **1937**

Drywall  
Painter  
Tiler  
Flooring installer  
Facade installer  
Roofer  
Mason  
Landscaper







# MAKING TOOLS FOR BUILDING PROFESSIONALS SINCE 1937

**For over 85 years, EDMA has been manufacturing and marketing tools for building professionals and DIY users.**

Discover a complete range of quality, innovative products for drywallers, painters, tilers, flooring installers, facade installers, roofers, masons and landscapers to provide them with real solutions for real time and effort saving day to day work.

## EDMA EXCLUSIVE DISTRIBUTOR OF CONDTROL BRAND IN FRANCE

In February 2022, EDMA acquired TOPOMESURE, adding a complete range of measuring instruments, professional laser levels and diagnostic tools to its range of tools for professionals building workers.

Condtrol powered by Edma, is the know-how, experience and expertise to provide professionals a reference measurement.



# RESPONSIBLE FRENCH MANUFACTURING

Based in the south-east part of France, **EDMA is committed to manufacturing a growing number of products in France**, while continuing to integrate its business into a global approach to sustainable development.



## FRENCH INDUSTRY

In 2020, EDMA was awarded the French Fab label, which embodies the desire for French industry to be innovative, export-oriented and open to change.

With this strategic approach in mind, in 2023 EDMA has been optimising its production resources and relocating all its teams from Baillet-en-France (95) and Saint-Raphaël (83) to a brand new 6,300 m<sup>2</sup> building in Puget-sur-Argens (83). This relocation, which complements the company's existing production facilities, has given EDMA the opportunity to install new machinery, enabling it to internalise the know-how involved in manufacturing its products.

## A COMMITTED COMPANY

For over 10 years, EDMA has consistently renewed its ISO 9001 certification primarily driven by a commitment to excellence.

However, it is more recently, since 2023, that Edma can assure its clients and partners of the control of its environmental impact through ISO 14001 certification and obtaining the PEFC label.

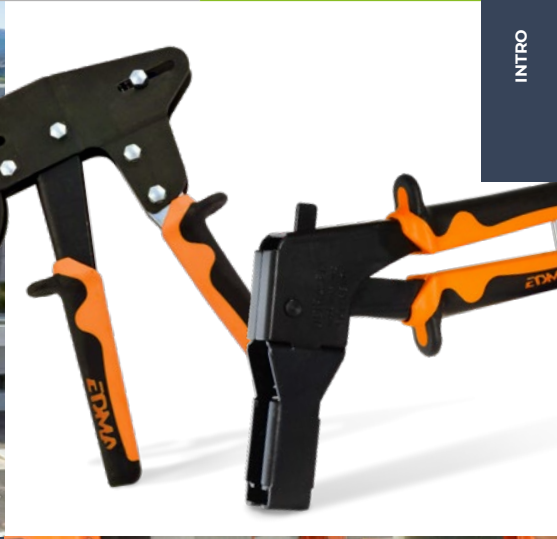

Decorated with the Ecovadis silver medal, EDMA is among the top 8% of the most high-performing companies in the sector of manufacturing Hand Tools, and Hardware.

## RESPONSIBLE PACKAGING

As part of our commitment to responsible packaging, many of our products have been redesigned to significantly reduce the use of plastic in favour of recyclable cardboard.

## REPAIRABLE TOOLS

Many EDMA tools are designed in such a way that one or more of their component parts can be replaced.

This repairability allows users to extend the life of their EDMA tools and helps to reduce waste production.

An online shop at [www.edma.fr/en](http://www.edma.fr/en) offers all available EDMA spare parts for sale.







# INNOVATION AND QUALITY AT THE HEART OF OUR DNA

Because EDMA understands the daily challenges faced by professionals building workers, our tools are designed in a constant quest for innovation and quality to provide real **«TIME AND EFFORT SAVING SOLUTIONS»**.

## CLOSE TO PROFESSIONAL USERS

Thanks to the close relationship that EDMA cultivates with the users of its products, it is able to gather their needs and feedback, which feeds into the design of ever more appropriate and efficient tools.

## QUALITY & STRENGTH

Whether for handling materials, cuts precision or the fasteners strength, our products are designed to guarantee superior results.

Quality is present at every stage in the design and manufacture of EDMA tools. It is a combination of field experience and technological advances. Various certifications attest to this constant concern, such as ISO 9001 and LNE.



Drywaller



Painter



Tiler



Flooring installer



Facade installer



Roofer



Mason



Landscaper



# TOOLS EXPORTED WORLDWIDE

**EDMA products are recognised by professionals and occasional users on all 5 continents and are exported to 60 countries.**

Present in many tool shops in France, EDMA also has a strong export culture. The «Authorised Economic Operator» (AEO) approval obtained in 2020 facilitates and secures its trades and transactions at international customs level.

Thus, EDMA continues its evolution and development, started over 85 years ago, while demonstrating more than ever its commitment to the values of innovation and quality that it holds close. Today, EDMA has more than 60 employees and a strong sales force, contributing to the daily growth of the business. All EDMA services, whether administrative, commercial, or logistical, are capable of responding to various national and international demands.

**EDMA**<sup>®</sup>  
UN OUTIL D'AVANCE



PRESENT IN OVER  
**60 COUNTRIES**

**+ 8000  
DISTRIBUTORS**



# EDMA<sup>®</sup>

UN OUTIL D'AVANCE

## IN NUMBERS

**+ 1 500**

**TOOL  
REFERENCES**  
SAVE TIME AND  
EFFORT

**1937**

**CREATION  
OF THE SOLE  
PROPRIETORSHIP  
PIERRE GREHAL**



**8**

**PROFESSIONS**

**1950**

**CREATION OF  
THE FAMOUS  
NIBBLER  
SHEARS**



**1953**

**REGISTRATION  
OF THE EDMA<sup>®</sup>  
TRADEMARK**

**5 PATENTS  
A YEAR**

ON AVERAGE  
SUBMITTED  
BY OUR R&D  
DEPARTMENT







**+ 80**

ROBUST AND  
RELIABLE  
PRECISION  
MEASUREMENT  
TOOLS



**2022**

**EDMA ACQUIRES  
TOPOMESURE AND  
BECOMES EXCLUSIVE  
DISTRIBUTOR OF THE  
CONDROL® BRAND IN  
FRANCE**



**2023**

**RELOCATION OF  
HEAD OFFICE AND  
MANUFACTURING  
PLANT TO  
PUGET-SUR-ARGENS**



**6 300 M<sup>2</sup>  
OF BUILDING  
DEDICATED  
TO FRENCH  
KNOW-HOW**



## YOUR ORDERS

Your orders are processed in the shortest possible time by a team of multilingual collaborators.

» [commercial@edma.fr](mailto:commercial@edma.fr)



## YOUR QUESTIONS

Technicians help you to use your EDMA tools as efficiently as possible and answer your different technical and after-sales questions.

» [qualite@edma.fr](mailto:qualite@edma.fr)



**EDMA**  
UN OUTIL D'AVANCE

**BY  
YOUR  
SIDE**

## EDMA VIDEOS

Learn how to assemble and/or use your favourite EDMA products in the EDMASCOPE videos series, available on EDMA's Youtube channel:

» [https://bit.ly/EDMASCOPE\\_YOUTUBE](https://bit.ly/EDMASCOPE_YOUTUBE)



**EDMA  
SCOPE**  
La chaîne vidéo



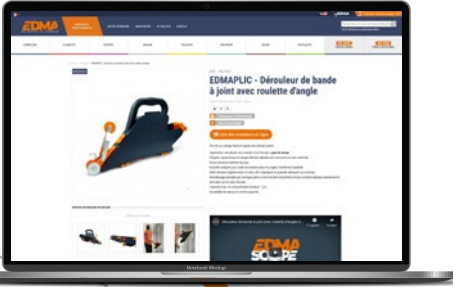

## EDMA WEBSITE

Find out a large amount of information on EDMA's website [www.edma.fr/en](http://www.edma.fr/en): products datasheets, pictures, videos, spare parts' lists linked to a product...

Create your [myEDMA](#) account on EDMA's website to benefit from even more content on your products.



«To be at your side» means to bring a maximum of services along your customer experience with EDMA.

## SPARE PARTS ONLINE SHOP

Give a longer life to your EDMA products by replacing some wearing parts. Find all the available EDMA spare parts and consumables and order them in a few clicks from home.



## CLEARANCE ONLINE SHOP









Benefit from bargains with EDMA tools from previous generations (previous colors, logo and packagings, discontinued products...etc) at discounted prices.







# CONTENTS

	<b>DRYWALLER</b>	<b>14</b>
	<b>PAINTER</b>	<b>82</b>
	<b>TILER</b>	<b>100</b>
	<b>FLOORING INSTALLER</b>	<b>132</b>
	<b>FACADE INSTALLER</b>	<b>148</b>
	<b>ROOFER</b>	<b>176</b>
	<b>MASON</b>	<b>228</b>
	<b>LANDSCAPER</b>	<b>248</b>
	<b>INDEX</b>	<b>276</b>

Find all our tools, videos  
and much more at

[WWW.EDMA.FR/EN](http://WWW.EDMA.FR/EN)

# DRYWALLER RANGE

## ERGONOMICS AND EASY USE

EDMA's range of specific tools for plasterboard is designed to give users a real time and effort saving on daily work.

Find out the entire range of must have tools for installing your linings, partitions, and ceilings.

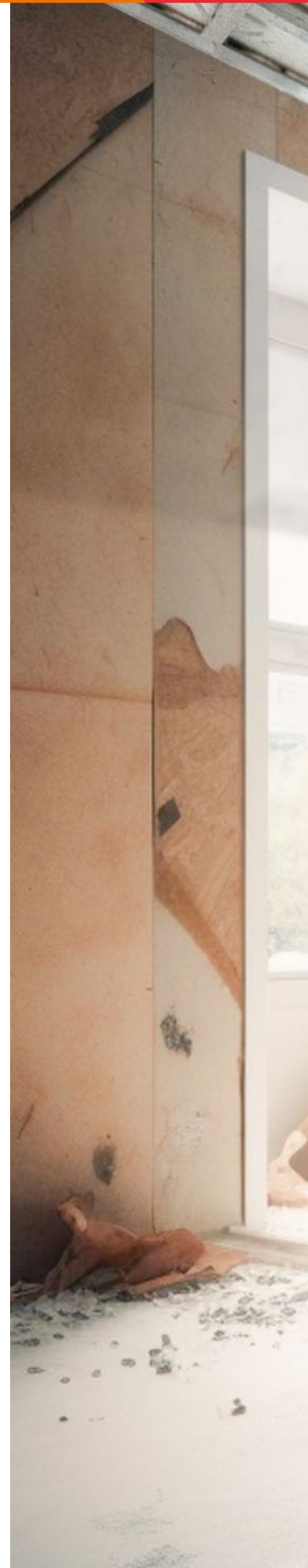







**NEW**

## STORAGE CASE

**Lightweight and impact resistant.**

Made of EVA and elastane.

Zip closure system with 2 sliders.

Zipped interior storage net.

Equipped with a handle for easy transport.

STORAGE CASE	S	XL
Ref.	743035	743036
Dimensions	650 x 250 x 90 mm	1350 x 350 x 100 mm



Ref.: 743006 **EDMABOX**

## STACKABLE STORAGE BOX

Compatible with Sortimo and L-BOXX system.

### DIMENSIONS

Outer	445 x 358 x 118 mm
Inner	378 x 313 x 65 mm



Ref. : 743032

## TOOL TRAY

**EDMABOX compatible**

**Made of high-resistance polyester.**

Sturdy plastic base protecting from shocks and dirt.

Convenient, accessible storage, offering better visibility of contents.

Metal carrying handle with foam padding + adjustable shoulder strap = comfort of use.

Thanks to its coupling levers, the tray can be stacked on the EDMABOX (or other L-Boxx) to optimize the transport of tools.

The integrated interfaces on the sides allow the use of ProClick bags and accessories. Equipped with reflective safety strips.

### SPECIFICATIONS

Max. load	24 kg
Dimensions	480 x 240 x 330 mm

### STORAGE COMPARTMENTS

Exterior compartments	8
Flap pocket with self-gripping fastener	1
Interior loops	16
Exterior loops	5
Zippered pocket ideal for storing a hacksaw	1
Bands with self-gripping fastener to hold a level	2



Ref. : 260055

### LEATHER TOOL POUCH

Made of smooth top-grain cowhide leather.  
Clip-on, adjustable belt included.

#### SPECIFICATIONS

Storage compartments	8
Tool holders	2
Tape measure holder	1



Ref. : 280155

### NYLON CONTRACTOR RIG

Reinforced adjustable belt with roller buckle.

#### SPECIFICATIONS

Storage compartments	8
Tool holders	2
Tape measure holder	1



Ref. : 280055

### NYLON CONTRACTOR RIG XL

Reinforced adjustable belt with roller buckle.

#### SPECIFICATIONS

Storage compartments	12
Steel hammer holders	2
Tape measure holder	1



Ref. : 280255

### JOINT KNIFE STORAGE POUCH

Nylon fabric  
With handle.  
Zip closure system.

#### SPECIFICATIONS

Storage compartments	6
----------------------	---





## MAGNETIC TAPE MEASURE

### DIMENSIONS

Ref. : 175555	5 m x 25 mm
Ref. : 175855	8 m x 25 mm 

### Magnetic *double hook* for easy measuring.

- Nylon-coated tape protected against dust and water.
- Double marking : horizontal and vertical reading.
- Class II accuracy.
- Ergonomic and compact design.
- Reinforced and anti-slip case.
- Equipped with 2 buttons: braking and locking of the tape.
- Belt hook + leash.

Complies with the applicable essential requirements of Directive 2014/32/EU of the European Parliament and of the Council of 26 February 2014, Module D1.

Ref. : 175055

## TAPE MEASURE 5 m x 25 mm

- Antishock rubber box.
- Nylon coated tape protected against dust and water.
- Class II accuracy.
- Equipped with 2 buttons: braking and locking of the tape.
- Belt hook + leash.

Complies with the applicable essential requirements of Directive 2014/32/EU of the European Parliament and of the Council of 26 February 2014, Module D1.





Ref. : 010755 **FLYER'S**  
**FORGED AVIATION SNIP**

Drop forged chromium molybdenum steel jaws.  
 Effortless cut.  
 Blade length : 42 mm.  
 Handle spring.  
 One hand automatic latch release.  
 Finger guard.

**CUTTING CAPACITIES**

Stainless steel	0,8 mm
Soft metal	1,2 mm

Ref. : 109055  
**Left cut**



Ref. : 010955  
**Right cut**

**APOLLO**  
**FORGED AVIATION SNIP**

Articulated tin snip.  
 Drop forged chromium molybdenum steel jaws.  
 Blade length : 35 mm.  
 Handle spring.  
 One hand automatic latch release.  
 Finger guard.

**CUTTING CAPACITIES**

Stainless steel	0,9 mm
Blue sheet steel	1 mm
Galvanised sheet, zinc	1,2 mm
Copper, brass, sheet metal	1,5 mm
PVC, aluminium	2 mm
Polycarbonate	2,5 mm



Ref. : 074555 **PLURICOUP' ERGO**  
**MULTI PURPOSE PLIERS WITH ANGLED BLADES**

**Light and handy.**  
 42 mm stainless steel polished serrated blades.  
 Ergonomic handles and easy-to-close latch.  
 Angled blades for an optimum comfort while cutting.

# CHOOSE YOUR GUILLOTINE FOR METAL PROFILES AND THREADED RODS



SPECIFICATIONS	STUD CUTTER	PROFILCUT®	PROFILCUT® MEGA	DUOTOP	MINI RODCUT M6
Ref.	161555	061755	065855	061655	065055
Profiles from 40 to 100 mm wide			✓		
48 mm tracks	✓	✓	✓	✓	
48 mm studs	✓	✓	✓	✓	
F530 studs	✓	✓	✓	✓	
F530 tracks		✓			
Corner beads	✓	✓	✓	✓	
Ceiling suspension system (T form)	✓	✓		✓	
M6 threaded rods (ø 6 mm)				✓	✓
Ø 4 mm metal wires				✓	✓



Ref. : 161555 **STUD CUTTER**

## **GUILLOTINE FOR METAL STUDS AND TRACKS**

**Allows to quickly cut without burr 48 mm studs and tracks, corner beads, ceiling suspension system and F530 studs thanks to its adaptor.**

Time-saving.  
Noise free.  
No sparks, no metal filings.  
+ F530 adaptor.



Ref. : 068655  
**F530 ADAPTOR**



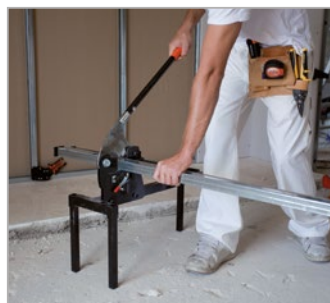

Ref. : 061755 **PROFILCUT®**

## GUILLOTINE FOR METAL STUDS AND TRACKS

**Effortless** *clean cut* **without burr.**

Time-saving.

Noise free.

No sparks - No risk of fire - No special permit.

No metal filings.

**4-die revolver plate for 6 shapes of metal profiles : F530 studs and corresponding tracks, 48 mm studs and tracks, corner beads and ceiling suspension system.**

Quick change of dies.

Trestle for optimal positioning of the profile.

Adjustable stop for custom cutting.

Integrated chip ejector prevents the revolver plate from jamming.

Support feet included.



Ref. : 065855 **PROFILCUT® MEGA**

## GUILLOTINE FOR METAL PROFILES UP TO 100 MM WIDE

Fast and *clean cut* without burrs.

Compact ergonomic design.

Time-saving, noise free, no sparks and no steel filings.

**Double non-sharp cutting blade to adapt to the width of the profile, from 40 to 100 mm :**

- **Narrow blade: from 40 to 60 mm + F530 profile.**

- **Wide blade: from 60 to 100 mm.**

Max. height of studs and tracks: 60 mm.

Width of dies easily adjustable to fit the profile.

Also cuts corner angles.

Integrated F530 die.



Ref. : 506583  
**SPARE DOUBLE BLADE**

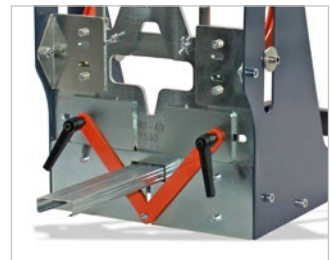

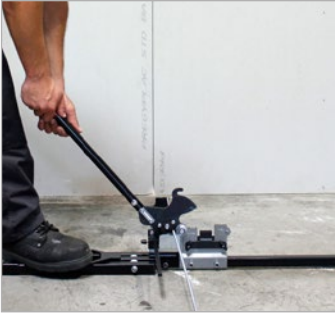

Réf. : 061655

**DUOTOP**

## **GUILLOTINE FOR 48 MM METAL STUDS AND TRACKS, M6 THREADED ROD**

**Allows to cut 48 mm metal studs and tracks, corner beads, ceiling suspension system, F530 profiles, M6 threaded rods and Ø 4 mm metal wires.**

Ideal to install drywall suspended ceilings.



*Clean cut* without burr.

No noise.

No sparks - No risk of fire - No special permit.

Immediate bolting, can be used to repair damaged rod.

545 mm adjustable cutting guide can be positioned on the right or left.

Up to 6.6 soft steel : 60 kg/mm<sup>2</sup>.

Cannot cut stainless steel threaded rod.



Ref. : 068655  
**F530 ADAPTOR**



Ref. : 165055  
**SPARE DIE**



Ref. : 065055

**MINI RODCUT M6**

## **6 MM (M6) THREADED ROD AND 4 MM SUSPENSION WIRE CUTTER**

*Clean cut* = immediate bolting.  
No noise.

Can be used to repair damaged rod.  
No metal scrap (no metal filings).  
No sparks - No risk of fire - No special permit.  
545 mm adjustable cutting guide can be positioned  
on the right or left.

Up to 6.6 soft steel : 60 kg/mm<sup>2</sup>.  
Cannot cut stainless steel threaded rod.

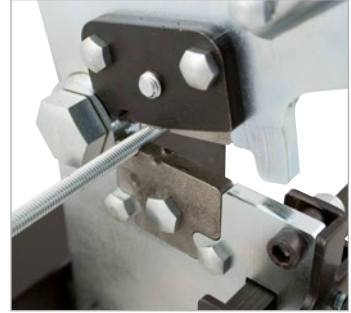

Ref. : 165055  
**SPARE DIE**





Ref. : 060755 **ALU LINE**  
**ALUMINIUM CHALK**  
**LINE REEL**  
**30 m**



Built-in filter system to prevent excess chalk.  
 Rope diameter: 1 mm.  
 Capacity: 80g.

Ref. : 060555 **FAST LINE**  
**FAST REWINDING**  
**CHALK LINE REEL**  
**30 m**



Rewinds 5 times faster.  
 Built-in filter system to prevent excess chalk.  
 Rope diameter: 1 mm.  
 Capacity: 100 g.

Ref. : 060955 **MAX LINE**  
**CHALK LINE REEL**  
**WITH LARGE HANDLE**  
**50 m**



For long distance marking.  
 Built-in filter system to prevent excess chalk.  
 Rope diameter: 2,5 mm (braided).  
 Capacity: 300 g.



Ref. : 160555  
 Ø 1 MM BRAIDED  
 SPARE ROPE FOR  
 FAST LINE AND  
 ALU LINE



Ref. : 260555  
 Ø 2.5 MM BRAIDED  
 SPARE ROPE FOR  
 MAX LINE



**MARKING CHALK**

WEIGHT	200 G	400 G	1 000 G	3 500 G
<b>BLUE</b> (Ref.)	063355	063255	063155	065255
<b>RED</b> (Ref.)	063855	064955	064355	065155

## LEVEL WITH XL MAGNETIC SLOTS

**Special for back-to-back studs**



90 cm aluminium level profile.

900 g/m profile = strong.

76 mm slots to fit all types of studs, even back-to-back or F530 studs.

Put the studs against the left edge of the slot to ensure a precise spacing.

Built-in carrying handle.

### 2 epoxy locked, solid acrylic vials :

- 1 vertical vial also visible from the front by mirror effect

- 1 horizontal vial

Milled surface.

Shockproof end caps.

Accuracy : 0.5 mm/m.

LEVEL WITH SLOTS	90 CM	120 CM
Ref.	175455	175355
Magnetic slot	3	4
Built-in gauge to install studs quicker and easier	Spacing of 40 and 60 cm	Spacing of 40, 60 and 90 cm*

The spacing of 90 cm is dedicated to 90 cm plasterboards installation, special for collective housing constructions.

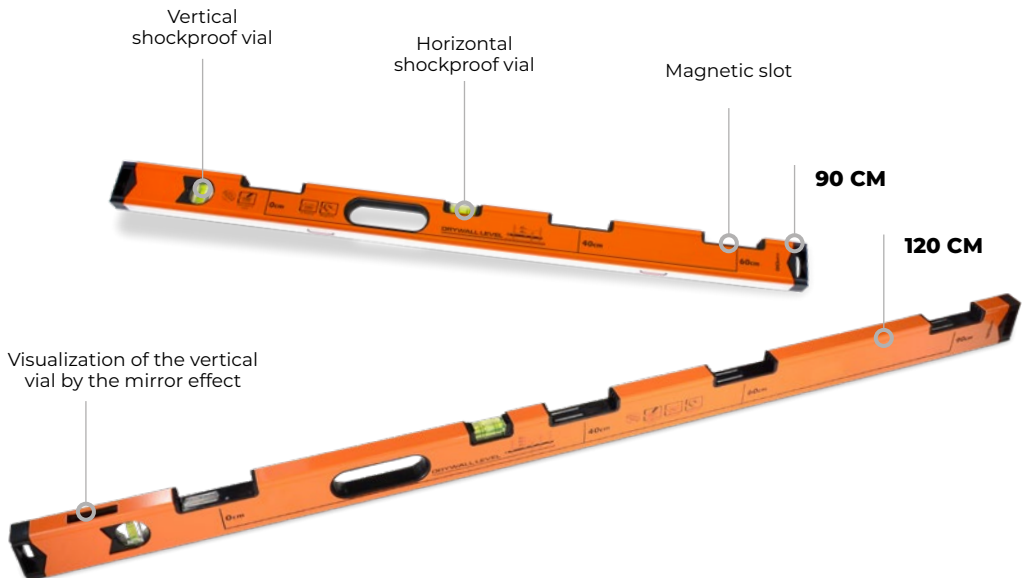

# CHOOSE YOUR SECTION SETTING PLIERS



SPECIFICATIONS	PROFIL	PROFIL 2 RM	MASTER-PROFIL®	ERGOTOP®
Ref.	060055	061055	062055	061955
Max. capacity	1+1 mm	0,8 + 0,8 mm	1+1 mm	1+1 mm
One handed operation			✓	
Right and left setting		✓		✓
Back-to-back stud setting				



SPECIFICATIONS	ULTRA PROFIL®	DUO PROFIL	TWIN PROFIL®	POWER PROFIL
Ref.	066855	160455	060355	161455
Max. capacity	1+1 mm	1+1 mm	1+1 mm	1+1 mm
One handed operation	✓			✓
Right and left setting				✓
Back-to-back stud setting		✓	✓	



Ref. : 060055 **PROFIL**

## SECTION SETTING PLIERS FOR STUDS AND TRACKS

Max. capacity : 1 + 1 mm.  
Patented punch.  
Fastening 60 % stronger.  
30 % less effort.



Ref. : 060155  
**SPARE PUNCHING BLADE**

Ref. : 061055 **PROFIL 2 RM**

## SECTION SETTING PLIERS FOR STUDS AND TRACKS

Max. capacity : 0,8 + 0,8 mm.  
For right and left setting.  
Articulated head which is ideal along the wall.  
Patented punch.  
Fastening 60 % stronger.  
30 % less effort.



Ref. : 061855  
**SPARE PUNCHING BLADE**







**ONE  
HANDED  
OPERATION**

Ref. : 062055 **MASTER-PROFIL®**  
**ONE HAND SECTION  
SETTING PLIERS FOR  
STUDS AND TRACKS**

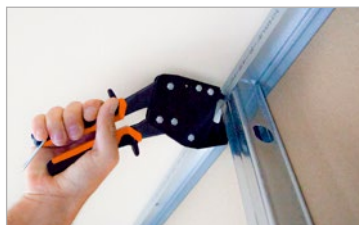
One handed operation.  
 Max. capacity : 1 + 1 mm.  
 Sprung handle.  
 Patented punch.  
 60 % stronger fastening.  
 30 % less effort.



 Ref. : 062155  
**SPARE PUNCHING BLADE**

 Ref. : 062255  
**SPARE SPRING**  
 x 5 pcs.

Ref. : 061955 **ERGOTOP®**  
**SECTION SETTING PLIERS  
FOR ALL TYPES OF STUDS  
AND TRACKS**

**For all types of studs and tracks, F530  
studs and corresponding tracks.**  
 Max. capacity : 1 + 1 mm.  
 For right and left setting.  
 Patented punch.  
 Fastening 60 % stronger.  
 30 % less effort.



 Ref. : 061855  
**SPARE PUNCHING BLADE**



ONE  
HANDED  
OPERATION

Ref. : 066855 **ULTRA PROFIL®**

## SECTION SETTING PLIERS FOR ALL TYPES OF STUDS AND TRACKS

**Effortless one handed operation**

**For all types of studs and tracks, F530 studs and corresponding tracks.**

Effortless one handed operation thanks to its ratchet system (3 notches to move the punch to the metal framing and 1 notch and a half to crimp).

Max capacity : 1 + 1 mm.

Patented punch.

Fastening 60 % stronger.

30 % less effort.



Ref. : 566855  
**SPARE PUNCHING BLADE**





Ref. : 160455 **DUO PROFIL**

## SECTION SETTING PLIERS FOR BACK-TO-BACK STUDS

Specially designed to crimp back-to-back metal studs.  
 Recommended in case of ceiling above 2,50 m height.  
 Regular stud-to-track crimping from 90 mm width.  
 Max. capacity : 1 + 1 mm.  
 Holding magnet included.





 Ref. : 260455  
**SPARE PUNCHING BLADE**

Ref. : 060355 **TWIN PROFIL®**

## SECTION SETTING PLIERS FOR BACK-TO-BACK STUDS

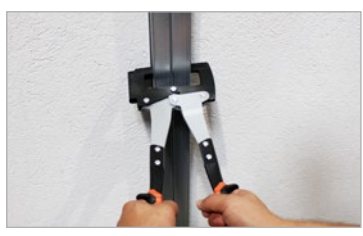
**Easy to use and time-saving.**  
 Large jaw opening to crimp back-to-back studs in one shot.  
 Regular stud-to-track crimping from 90 mm width.  
 Max. capacity : 1 + 1 mm.  
 Holding magnet included.  
 Patented punch.  
 Fastening 60 % stronger.  
 30 % less effort.



 Ref. : 061855  
**SPARE PUNCHING BLADE**



Ref. : 161455 **POWER PROFIL**

## **AUTOMATIC SECTION SETTING PLIERS FOR ALL TYPES OF STUDS AND TRACKS, FITS ON CORDLESS POWER DRILLS/ SCREWDRIVERS**

**No crimping *effort***: let the drill do the job !

To crimp all types of studs and tracks (even F530 studs for ceiling application).

Max. capacity: 1 + 1 mm.

It fits all types of cordless power drills/screwdrivers (from 14,4 Volts).

Patented punch.

Fastening 60 % stronger.

30 % less effort.



Ref. : 061855  
**SPARE PUNCHING BLADE**









Ref. : 162655

## STEP DRILL

**Use for precision drilling of sheet metal and plastic up to 30 mm**

HSS.

Drilling Ø : from 4 to 30 mm in 2 mm increments.

Max. drilling depth : 3 mm.

Stud drilling (even back-to-back type) to insert pipes.



Ref. : 069055

**CANALCUT**

## PRECISION INSULATION CUTTER

**For all types of insulation materials, such as : E.P.S., polyurethane, rock wool, glass wool, underfloor heating.**

Groove stainless steel blade for making 35 mm (width) x 35 mm (depth) channel to insert pipes up to 32 mm diameter max.

### 2 INTERCHANGEABLE BLADES :

#### 1/ 35 x 35 mm groove blade :

Thermal bridges are easily avoided while cutting.

#### 2/ 80 mm blade for curved shape removal :

Scoring E.P.S. plasterboard.

Roofing water insulation grading.

To cut insulation material.

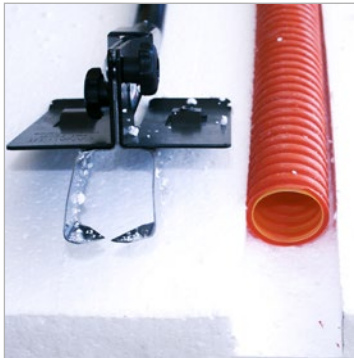

Ref. : 069555

**GROOVE BLADE 35 X 35 MM**



Ref. : 068155

**BLADE SET 40, 60, 80, 100 MM**



## INSULATION CUTTER

Easy to use for all types of insulation materials.

2 different tooth shapes.

Holster included.

Symmetrical bi-material handle.

To cut without any effort rock wool, glass wool, wood wool or hemp insulating panels, flax, cellulose wadding panels, etc... from 3 to 20 cm thick.



DIMENSIONS	300 MM	420 MM
Ref.	066455	168055

Ref. : 064655 **ROLL PLAC**

## **MINI TROLLEY FOR BOARD CARRYING**

**Effortless and autonomous  
plasterboard carrying.**

Allows to carry up to 2 boards by one person.

2 built-in wheels for a fast, effortless movement in a comfortable position.

The wide base allows a better stability and prevents from damaging the plasterboard.

Steel frame = strong.

Bi-material handle for an optimum comfort.

Light and compact tool = very easy to store.



Ref. : 064555 **TRANSPLAC**

## **HEAVY DUTY BOARD LIFTER**

Allows to carry boards and panels by one person.

Wide base for better stability.





Ref. : 064055 **DUOPLAC**  
**BOARD CARRIER HANDLES**

Set of 2 pieces.  
 Steel handles to carry boards and panels by 2 persons.  
 Anti-slip grips



Ref. : 066055 **FOOTPLAC**  
**BOARD LEVER WITH STEEL STIRRUP**

To lift panels for an accurate positioning thanks to its rocker system.  
 Wide base for better balance.  
 Ideal to unhinge doors.  
 Extra wide loop suitable for most safety footwear.

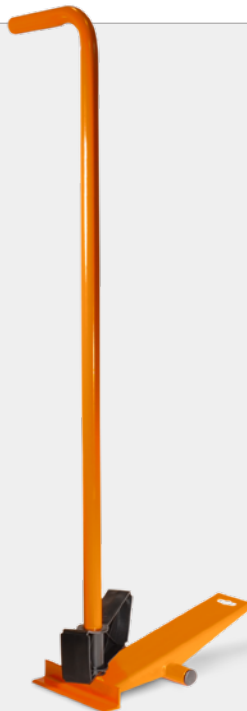

Ref. : 066555 **BLOCPLAC**  
**BOARD HOLDER**

**Durable tool and easy to use.**  
 Allows to work alone thanks to the moveable block.  
 To lift and to hold the board or insulation panel in position while screwing it to the metal framing.  
 Offset handle.  
 Beveled edge to avoid damaging the plasterboard.



Ref. : 064755 **VARIO RAP**  
**PLANE FOR  
 PLASTERBOARDS &  
 WOOD**

3 adjustable working positions.  
 Replaceable rasps.



Ref. : 164755  
**FLAT RASP**



Ref. : 066755 **EASY RAP**  
**MINI PLANE FOR  
 PLASTERBOARD**

Compact, ergonomic design.  
 Replaceable rasp.



Ref. : 166755  
**FLAT RASP**



Ref. : 163155  
**DRYWALL SCORING  
 SQUARE**

Fast and clean cut.  
 Max. 62 cm.  
 Ideal to score and cut plasterboard.  
 Compatible with all types of utility knife.  
 Double measurement units : inch/mm.





Ref. : 160655

## DRYWALL UTILITY KNIFE

With 25 mm snap-off blades

3 spare blades included.  
Security locking blade action.  
Ergonomic and heavy duty design.



Ref. : 160755  
**SNAP-OFF  
BLADE**  
25 mm x 10 pcs.

## SNAP OFF KNIFE WITH ZINC-ALLOY BODY

**DIMENSIONS**      **9 MM**      **18 MM**

Ref.                      170355      170455



Ref. : 170255

## FOLDABLE KNIFE

Ergonomic design.  
Security locking system.  
Quick blade-changing system.



**SPARE BLADES  
FOR CUTTERS  
REF. 170255,  
060655, 170155**



Ref. : 170755  
**TRAPEZE  
CUTTER  
BLADE  
DISPENSER**  
50 blades.

Ref. : 060655

## FOLDABLE KNIFE WITH HOLSTER

Foldable knife for trapeze blades and  
hook blades.  
4 blades storage compartment.  
Holster included.



**SPARE BLADES  
FOR CUTTERS  
REF. 170255,  
060655, 170155**



Ref. : 199255  
**TRAPEZE  
BLADE FOR  
CUTTER**  
x 10 pcs.

Ref. : 170155

## DUAL-SYSTEM KNIFE

Cut string integrated.  
4 blades in the storage  
compartment + 1 on the cutter.  
Quick blade-changing system.  
Soft-touch grip.



Ref. : 170655

## SAFETY KNIFE

Safety carton and plastic film opener.  
Double blade not replaceable.



Ref.: T74255

## PLASTERBOARD SAW

**550 mm**

Blade thickness : 0.85 mm.

Non-stick coating.

8 teeth per inch.

Triple bevel teeth.



**Holster included**



### CROCOPLAC II

## JAB SAW WITH TEETH ON BOTH SIDES

To cut plasterboard, cellular concrete, wooden panels, etc...

Triple bevel blade and teeth on both sides for multidirectional cutting.

8 teeth per inch.

Trident head to make the pre-holes or metal anchor installation.

Light and easy to handle.

Ergonomic bi-material handle.



#### DIMENSIONS

	150 MM	250 MM
Ref.	067055	067255



Ref. : 062955 **PLAC & ROLL**

## DRYWALL STRIPPER

Fast and simultaneous cutting on both sides of the plasterboard.

Adjustable cutting depth up to 150 mm.

Adjustable wheels for a cutting thickness up to 18 mm.

2 ergonomic bi-material handles for straight and guided cuts



Ref. : 506292  
**SPARE WHEEL**  
x 2 pcs.



Ref. : 069255

**RAP-PLAC VERSATILE**

## CHAMFERING PLANE FOR PLASTERBOARD

**Zinc plated steel body = durable tool.**

Chamfering angle : from 22 to 45°.



Ref. : 199255  
**TRAPEZE BLADE FOR CUTTER**  
x 10 pcs.

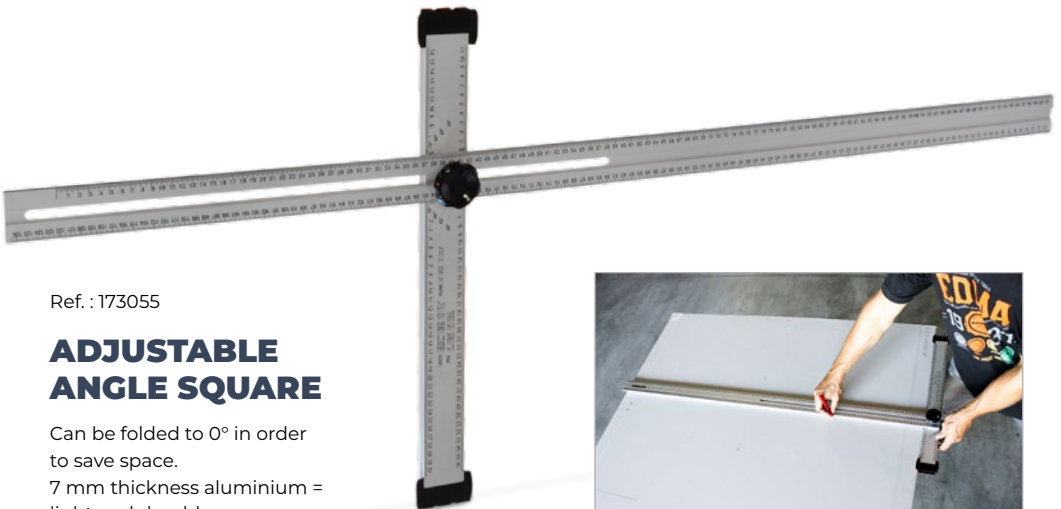

Ref. : 173055

## ADJUSTABLE ANGLE SQUARE

Can be folded to 0° in order to save space.

7 mm thickness aluminium = light and durable.

Length : 120 cm.





**MAX.  
LOAD:  
80 KG**

**MAX. HEIGHT  
with extension :  
4,50 M**

**MAX. HEIGHT  
IN VERTICAL  
POSITION  
with 2,50 m height  
panel :  
5,75 M**

**UNIQUE**

Rack and pinion system

**SAFE**

Braking system

**EFFORTLESS**

Power drill support

**PRACTICAL**

Removable wooden board

**STABLE**

3 wheels including  
2 wheels with brake

CE

Ref. : 267355 **EDMAPLAC 450**



## RACK AND PINION PANEL LIFTER



### Power drill assistance *available.*

To lift plasterboard in every positions : horizontal (ceiling installation), angled (sloping ceiling installation) and vertical (wall installation).

Innovative braking system with 2 handles (main brake + safety brake) to lower the top rack quickly under control.

Automatic operation thanks to power drill assistance.

Its rack and pinion system allows to lift plasterboards with less effort.

Ergonomic design with bi-material handle to tilt the top rack up to vertical position.

Tool carrier wooden board included.

Easy to pass through doorway thanks to its foldable feet.

Equipped with 3 wheels Ø 125 x 32 mm, 2 of which with brake = better stability and safety.

No noise while lifting on job sites.

### SPECIFICATIONS

Max. load.	80 kg
Max. board dimensions	1,20 x 3,60 m
Min. board dimensions	0,15 x 0,60 m
Max. height with extension part	4,50 m
Max. height without extension part	3,50 m
Min. height	1,61 m
Max. height for vertical lifting with 2,50 m height board	5,75 m
Board loading height without extension part	84 cm
Min. width in moving/storage position	63 cm

CE certified.

Complies with European directive MACHINERY-2006/42/CE.

Approved by the VERITAS conformity report# 628 8214-1.



Ceiling installation

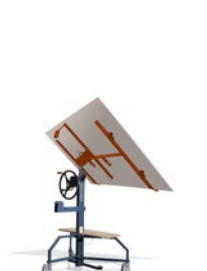

Sloping ceiling  
installation



Wall installation





# QUICK SUPPORT

*Safety* lock.



Ref. : 066355

**75-125 cm**

To block equipments during transport.  
 Extendable from 0.75 m to 1.25 m.  
 90° max. support : 60 kg.  
 65° max. support : 20 kg.  
 Articulated top and bottom pads.



Ref. : 068855

**101-177 cm**

To block equipments during transport.  
 Extendable from 1.01 m to 1.77 m.  
 90° max. support : 60 kg.  
 65° max. support : 20 kg.  
 Articulated top and bottom pads.



Ref. : 066155

**160-290 cm**

To hold plasterboard to the top.  
 Extendable from 1.60 m to 2.90 m.  
 90° max. support : 50 kg.  
 65° max. support : 20 kg.  
 Articulated top and bottom pads (20 x 6 cm).

Ref. : 067855

**210-390 cm**

To hold plasterboard to the top.  
 Extendable from 2.10 m to 3.90 m.  
 90° max. support : 40 kg.  
 65° max. support : 13 kg.  
 Articulated top and bottom pads (20 x 6 cm).



Ref. : 264055

**THE DIMPLER®**

## MAGNETIC DRYWALL SCREW RETAINER

*Powerful magnet.*

- Automatically countersinks screws to proper depth.
- Prevents stripping screw head.
- Eliminates paper tear of drywall.
- Ideal for plasterboard and particle board.
- Replaceable bit.
- Reverse mode.
- Not suitable for impact power drills.



Ref. : 564055

**PH2 DRYWALL BIT**



Ref. : 263955

## PH2 DRYWALL BIT

**x 6 pcs**

Depth stop to screw perfectly in plasterboards without drilling through them.



Ref. : 062855

**CORNER FIX**

## HAND TOOL FOR FIXING CORNER BEADS

*Easy punching.*

- For crimping expanded metal corner bead on outside corner.
- Ergonomic design.
- Replaceable jaws.



Ref. : 262855

**REPLACEABLE TIP**



Ref. : 162855

**REPLACEABLE JAW**

x 2 pcs.



**COVERABSORB**

**PROTECTION AND PACKING COVER**

For all types of surfaces.  
 Waterproof.  
 Absorbs possible shocks.  
 Anti-slip, enhances safety on site.  
 Quick installation and removal.  
 Width : 1 m.

LENGTH	10 M	25 M
Ref.	178555	178655



Ref. : 178855 **COVERPROTECT**

**ANTI-SLIP AND REUSABLE PROTECTIVE COVER**

For all types of surfaces.  
 Waterproof.  
 Absorbs possible shocks.  
 Anti-slip, reinforces safety on site.  
 Easy to install and remove.  
 Reusable.  
 25 m roll.  
 Width : 1 m.



Ref. : 178755 **COVERUP**

**ANTI-SLIP AND BREATHABLE PROTECTIVE COVER**

**Allows soil moisture to *evaporate*, prevents condensation.**

For all types of surfaces.  
 Waterproof against all types of liquids and projections.  
 Absorbs possible shocks.  
 Anti-slip, reinforces safety on site.  
 Easy to install and remove.

*Reusable.*

Robust = tear-resistant.  
 Easy to clean, leaves no residue.  
 25 m roll.  
 Width : 1 m.

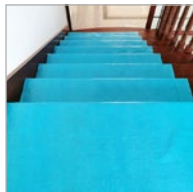



Anti-slip pads

Ref. : 260255

**STEP STOOL**  
**3 steps double sided**  
**Made of aluminium = light**

*Anti-slip* pads.  
 Double sided access.

**SPECIFICATIONS**

Max. height	65,4 cm
Max. load	150 kg
EN-14183 certified.	



Anti-slip pads

Ref. : 260355

**DRYWALL BENCH**  
**Made of aluminium = light**

*Anti-slip* pads.

**SPECIFICATIONS**

Length	98 cm
Width	45 cm
Working height	48,5 cm
Max. load	150 kg

96-333 decree compliant





Ref. : 161155

## DRYWALLER STILTS

**Made of aluminium = light and easy to handle**

*Optimized* comfort and stability.

Time-saving for work at height.  
Articulated to allow a fluid and stable walking.  
Adjustable nylon heels for comfort.

Equipped with quick release ankle straps.  
Calf and ankle protectors.

### SPECIFICATIONS

Adjustable height	from 45 cm to 76 cm
Max. load	102 kg

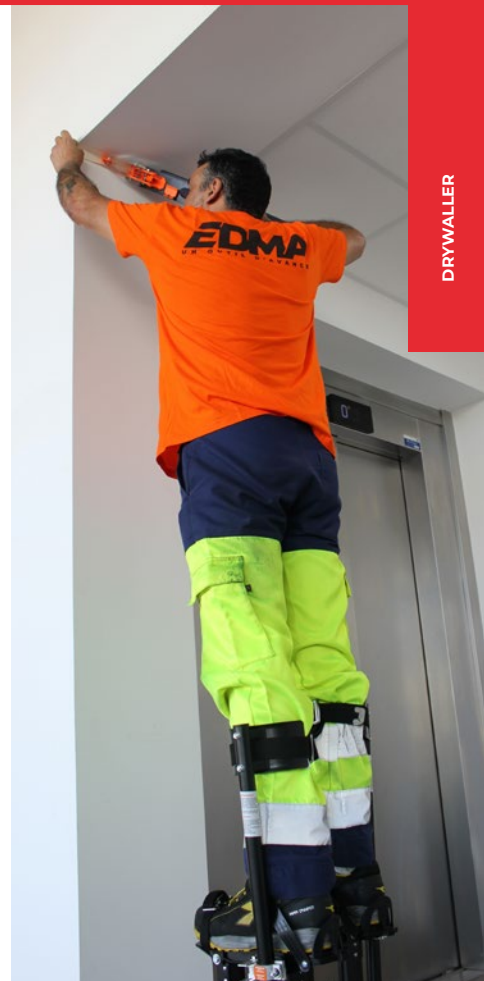

DRYWALLER



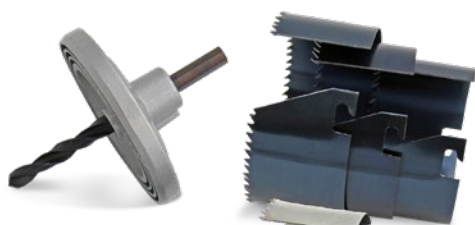

Ref. : 162255

### 3-HOLE SAW SET

Ø 60, 67, 74 mm

For plasterboard, wood, and PVC.  
Bayonet fastening system.

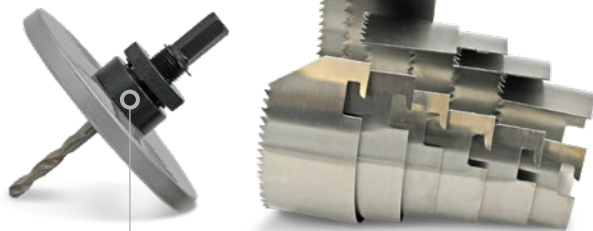

Ref. : 162355

### 6-HOLE SAW SET

Ø 60, 68, 74, 80, 90 and 100 mm

For plasterboard, wood, and PVC.  
Bayonet fastening system.

Drill locking system = better stability.



Ref. : 261255

**HOT BALL**

### STAINLESS STEEL HOT BALL

Ø 35 mm

To make a 40 mm diameter channel on insulating materials behind plasterboard without damaging them.

Perfect to make your multimedia connections, switch and socket installations invisible.

**Time-saving = no need to groove the wall and to repaint it!**

**Step 1 :** drill two 40 mm diameter holes on the plasterboard, in vertical way to each other with maximum 2,50 m width.

**Step 2 :** uniformly heat the hot ball surface with a welding torch during 3 minutes.

**Step 3 :** insert the hot ball into the hole above. The hot ball melts the polystyrene to make a channel connecting the 2 holes.



Ref. : 164355

## MULTI PURPOSE TOOL

8 cm

Stainless steel blade.  
Bi-material handle with metal head.



### FEATURES :

- Joint knife
- Unmasking knife
- Filling knife/crack cleaner
- Nail puller and hammer
- Paint can opener
- Roller cleaner
- Scraper
- Rasp
- Cutter
- 11 mm (1/4") wrench
- 14 mm (3/8") wrench
- Bottle opener

Ref. : 164555

## HEAVY DUTY SCRAPER

8 cm

Striking scraper, *adjustable* to a pole.  
Stainless steel blade.

Bi-material handle with metal head.  
Compatible with EDMA telescopic poles  
(not included, see page 73).



Ref. : 178055

**PATCH'UP**

## PLASTERBOARD REPAIRER

15 cm

Easy and *fast* to apply.

Fastly repairs damaged walls and ceilings. The repaired surface is smooth, clean and without any crack.

Light and self-adhesive for an easy application.

Made of galvanized steel for a permanent repair.

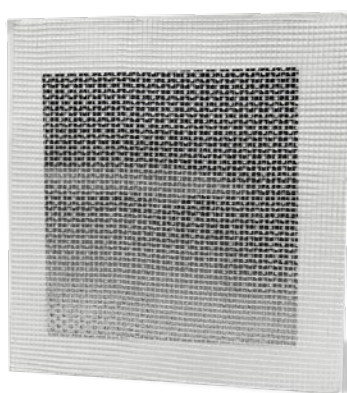

**Step 1 :** lightly sand around the area to be repaired and clean it. Remove the backing paper from the patch.

**Step 2 :** apply the patch on the area to be repaired and press firmly.

**Step 3 :** cover the entire patch and the surrounding area with compound. Let dry then sand to obtain a smooth surface. Repeat the operation if necessary.





Ref. : 283055 **NEW**

## GRADUATED MULTIFUNCTION BUCKET 33 l

Versatile = allows mixing, transporting, storing, distributing...

Integrated graduations (from 5 to 24 l) for dosing glue preparations, jointing, compound, mortars. Convenient to use thanks to its metal handle and its 2 side handles.

Easy to clean.

Transparent lid sold separately (ref. 528300).

### SPECIFICATIONS

Material	PP
Upper outer diameter	380 mm
Upper inner diameter	357 mm
Lower outer diameter	322 mm
Height	370 mm
Volume to the top edge	33 l



Ref. : 528300

## TRANSPARENT LID

For 33 l graduated  
multifunction bucket

Ref. : 276755

## BUCKET SCOOP KNIFE

**Allows to scrape/clean to the bottom of the bucket = avoids waste.**

Curved stainless steel blade facilitates the taking of compound.

Blade with a 13 cm radius and 16,5 cm width adapted to large buckets of compound.

Equipped with a hook to put the knife on the bucket.

Ideal for filling the EDMAPLIC drywall taper. Bi-material handle with metal head.

Stainless  
steel  
blade

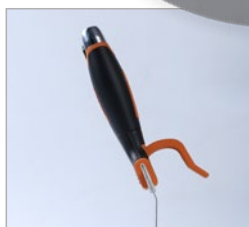



Ref. : 066655

**STAINLESS STEEL  
MUD PAN**

**300 mm**

Ideal for repairs on plasterboard.  
Very resistant.



Galvanized steel blade

Ref. : 066955

**PLASTIC MUD PAN**

**250 mm**

With galvanized steel blade to  
strike-off excess compound.  
Soft strap to easily hold the mud pan.  
2 knife holders.



Ref. : 069855

**DRYWALL TAPE  
HOLDER**

To hold and to dispense  
drywall tape.  
Can be hooked on belt.  
Quick opening design to  
replace tape easier.





Ergonomic handle

Holding hooks

Adjustable side strap

Built-in corner roller

Adjustable compound flow

Can be filled by filling tube

Quick roller lock



Ref. : 367955

**EDMAPLIC**

## **DRYWALL TAPER WITH CORNER ROLLER**

Allows *easy* and quick gluing of drywall tapes.

Simultaneous application of tape and compound = time saving.

Ergonomic handle and adjustable side strap for optimal grip.

Toothed wheels for easy application.

Max. capacity of the compound compartment : 1,8 l (around 2,5 kg of compound).

Possibility to switch to left-handed version.  
Built-in roller for gluing tape in corners, easily foldable.

Compound flow is adjustable in 5 steps to apply the right amount to the tape.

Filling the drywall taper with a filling tube is possible thanks to the opening cap and side hooks that hold it on the compound bucket.

Removable cover = easier cleaning.

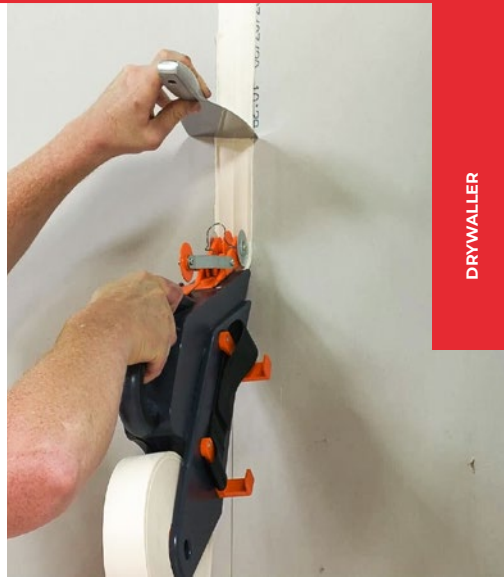



Ref. : 278055

## INSIDE CORNER ROLLER

To tighten the drywall tape in the horizontal and vertical inside corners.

Supplied with an adapter for connection to EDMA telescopic poles (not included, see page 73).

Also compatible with a handle with M10 female end.



Ref. : 278155

## OUTSIDE CORNER ROLLER

To tighten the drywall tape in the horizontal and vertical outside corners.

Supplied with an adapter for connection to EDMA telescopic poles (not included, see page 73).

Also compatible with a handle with M10 female end.



# CHOOSE YOUR JOINT KNIFE

	KNIFE TYPE	BLADE TYPE	AVAILABLE WIDTHS (CM)
	<b>JOINT KNIFE</b>	Flexible	2,5 / 4 / 6 / 8 / 10 / 12 / 15 / 18 / 20 / 22 / 24
	<b>JOINT KNIFE</b>	Stiff	4 / 5 / 8 / 10
	<b>JOINT KNIFE</b> With 4 removable bits	Flexible	10 / 12,5 / 15
	<b>PREMIUM JOINT KNIFE</b>	Flexible	4 / 6 / 8 / 10 / 12 / 15 / 20 / 25
	<b>PREMIUM JOINT KNIFE</b>	Stiff	4 / 5 / 8 / 10
	<b>JOINT KNIFE WITH ROUNDED BLADE</b>	Flexible	10 / 12 / 14 / 16 / 18 / 20 / 22 / 24 / 30
	<b>REINFORCED JOINT KNIFE</b>	Stiff	20 / 25 / 30 / 35
	<b>ERGONOMIC JOINT KNIFE</b>	Stiff	25 / 35 / 60

## JOINT KNIFE

Stainless steel blade, mirror finish.  
Bi-material handle with metal head.



JOINT KNIFE	2,5 CM	4 CM	5 CM	6 CM	8 CM	10 CM	12 CM	15 CM	18 CM	20 CM	22 CM	24 CM
Flexible blade (Ref.)	165255	165355	--	165455	165555	165655	165755	165855	265555	265655	265755	265855
Stiff blade (Ref.)	--	268155	268255	--	268355	268455	--	--	--	--	--	--

### Flexible blade



Stainless  
steel  
blade

### Stiff blade

Carbon  
steel  
blade





Ref. : 610160

## SET OF JOINT KNIVES + STORAGE POUCH

### COMPOSED OF

Ref. : 165355	JOINT KNIFE Flexible blade	4 CM
Ref. : 165655	JOINT KNIFE Flexible blade	10 CM
Ref. : 169255	JOINT KNIFE + 4 removable bits	15 CM
Ref. : 265655	JOINT KNIFE Flexible blade	20 CM
Ref. : 265855	JOINT KNIFE Flexible blade	24 CM
Ref. : 164355	MULTI PURPOSE TOOL	8 CM
Ref. : 280255	STORAGE POUCH for joint knives	



**Flexible blade**

## JOINT KNIFE

### With 4 removable bits



Flexible stainless steel blade, mirror finish.  
With removable PH1, PH2 bits as well as 5 mm and 6 mm flathead bits.

Integrated bit storage system in the handle.  
Bi-material handle with metal head.

JOINT KNIFE	10 CM	12,5 CM	15 CM
Flexible blade (Ref.)	169055	169155	169255



Ref. : 280255

## JOINT KNIFE STORAGE POUCH

Nylon fabric.  
6 storage compartments.  
With handle.  
Zip closure system.

# PREMIUM JOINT KNIFE

Single material, in stainless steel = *more resistant.*  
Mirror-finish blade.



PREMIUM JOINT KNIFE	4 CM	5 CM	6 CM	8 CM	10 CM	12 CM	15 CM	20 CM	25 CM
Flexible blade (Ref.)	181055	--	181155	181255	181355	181455	181555	182055	182155
Stiff blade (Ref.)	181655	181755	--	181855	181955	--	--	--	--

**Flexible blade**

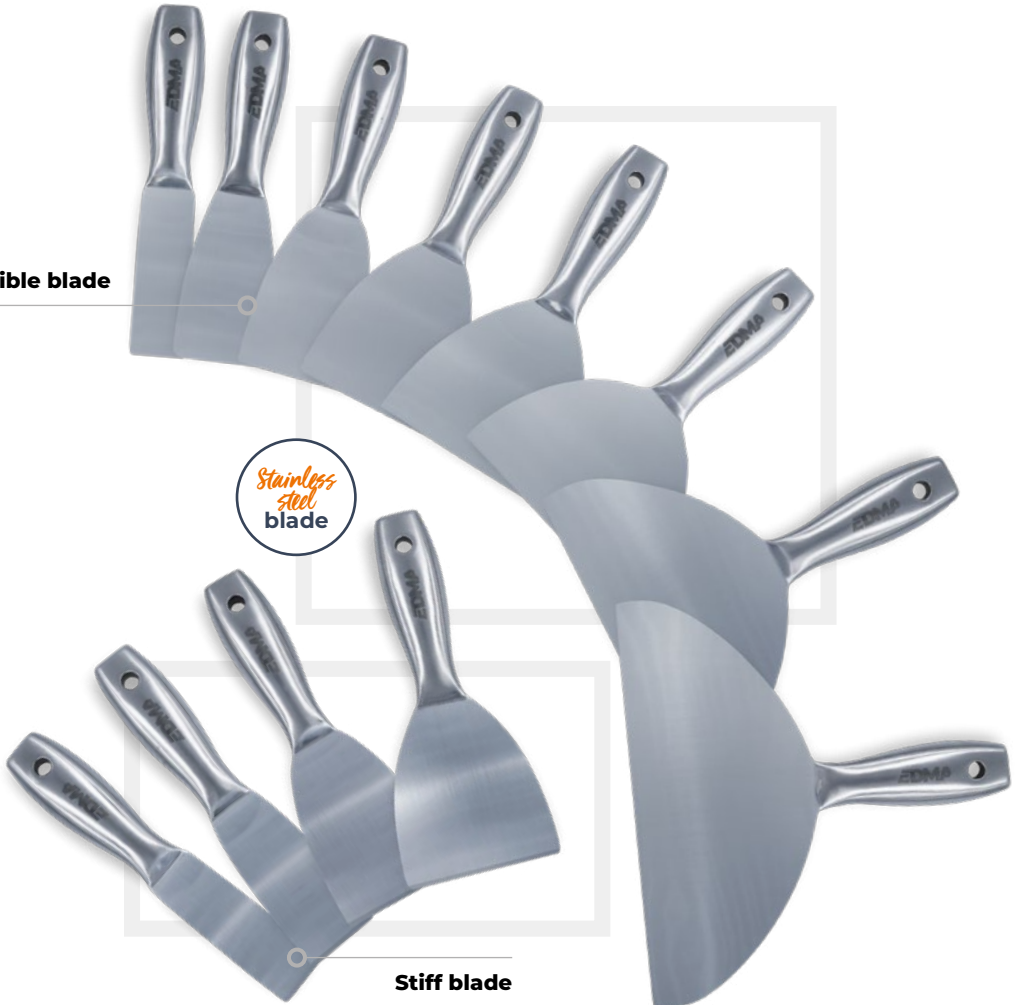

**Stiff blade**



Ref. : 610161

## SET OF PREMIUM JOINT KNIVES + STORAGE POUCH

### COMPOSED OF

Ref. : 181055	PREMIUM JOINT KNIFE Flexible blade	4 CM
Ref. : 181355	PREMIUM JOINT KNIFE Flexible blade	10 CM
Ref. : 181455	PREMIUM JOINT KNIFE Flexible blade	12 CM
Ref. : 181555	PREMIUM JOINT KNIFE Flexible blade	15 CM
Ref. : 182055	PREMIUM JOINT KNIFE Flexible blade	20 CM
Ref. : 164355	MULTI PURPOSE TOOL	8 CM
Ref. : 280255	STORAGE POUCH for joint knives	



## JOINT KNIFE WITH ROUNDED BLADE

0,5 mm thick stainless steel blade.  
 Rounded blade allowing to stay flat on the surface to work.  
 Reinforcement stiffening the blade over its entire width.  
 Bi-material handle with metal head.

JOINT KNIFE WITH ROUNDED BLADE									
	10 CM	12 CM	14 CM	16 CM	18 CM	20 CM	22 CM	24 CM	30 CM
Ref.	277055	277155	277255	277355	277455	277555	277655	277755	278255



## REINFORCED JOINT KNIFE

Stainless steel blade mounted on rigid aluminium reinforcement.

Bi-material handle with metal head.

REINFORCED JOINT KNIFE	20 CM	25 CM	30 CM	35 CM
Ref.	169355	169455	169555	169655

## ERGONOMIC JOINT KNIFE

Stainless steel blade mounted on rigid aluminium reinforcement.

Riveted bi-material handle.

Ideal to spread compound on large areas.



ERGONOMIC JOINT KNIFE	25 CM	35 CM	60 CM
Ref.	174355	174455	166355







Stainless  
steel  
blade

Ref. : 167055

## CORNER COATING KNIFE

Stainless steel blade.  
Ideal to spread compound in inaccessible areas.  
Bi-material handle with metal head.



Stainless  
steel  
blade

Ref. : 167955

## HALF ROUND KNIFE

Stainless steel blade.  
Ideal to spread compound in angles.  
Bi-material handle with metal head.



Stainless  
steel  
blade

Ref. : 065455

## INSIDE CORNER TROWEL

Stainless steel blade.  
To spread compound on both interior sides of the wall in one single pass.  
Ergonomic handle.  
Angle 103°.



Stainless  
steel  
blade

Ref. : 065755

## OUTSIDE CORNER TROWEL

Stainless steel blade.  
To spread compound on both exterior sides of the wall in one single pass.  
Ergonomic handle.  
Angle 87°.

Ref. : 164055

## RUBBER JOINT KNIFE

To joint inner angles as well as round and hard-to-reach areas.

With nylon reinforcement.

Very light and easy to clean.

Can be used by hand or with an handle (not included).



Ref. : 069955

## HAWK

**330 x 330 mm**

To hold compound before application.

Bi-material handle and EVA foam.

Aluminium blade with corrugated surface to maintain compound on the trowel.

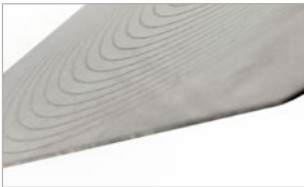



## PLASTERING TROWEL

Stainless steel blade.

Fiberglass-reinforced polyamide mounting = light and durable.

Bi-material handle.

			
BLADE	FLAT	CURVED	BEVELED
Ref.	266055	266155	266255
Dimensions	280 x 125 mm	280 x 125 mm	280 x 128 mm

**EDMABLADE**

**SMOOTHING BLADE**

Allows smoothing of compounds, drywall tapes, plaster.  
 Easy to use thanks to its light and ergonomic structure.  
 Stainless steel blade with rounded edges for a result without  
 trace or loss of compound.

EDMABLADE	15 CM	25 CM	35 CM	45 CM	60 CM	80 CM	100 CM
Flexible blade (Ref.)	171655	171755	171855	171955	172055	172155	172255
Stiff blade (Ref.)	371655	371755	371855	371955	372055	372155	372255

**Flexible blade**

Blade thickness : 0,3 mm.

**Stiff blade**

Blade thickness : 0,5 mm.

Adaptable to EDMA telescopic poles (handle and poles not included, see page 73).

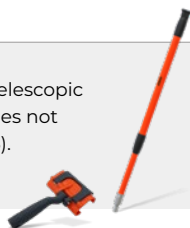



Ref. : 610190 **NEW**

# SET OF EDMABLADE S

## COMPOSED OF

Ref. : 743035	STORAGE CASE	S
Ref. : 171755	EDMABLADE - Flexible smoothing blade	25 CM
Ref. : 171855	EDMABLADE - Flexible smoothing blade	35 CM
Ref. : 171955	EDMABLADE - Flexible smoothing blade	45 CM
Ref. : 172055	EDMABLADE - Flexible smoothing blade	60 CM
Ref. : 271555	EDMABLADE - Handle	
Ref. : 179555	TELESCOPIC POLE	0,55 - 0,90 M
Ref. : 181555	PREMIUM JOINT KNIFE - Flexible blade	15 CM





Ref. : 610191 **NEW**

# SET OF EDMABLADE **XL**

## COMPOSED OF

Ref. : 743036	STORAGE CASE	<b>XL</b>
Ref. : 171655	<b>EDMABLADE</b> - Flexible smoothing blade	<b>15 CM</b>
Ref. : 171755	<b>EDMABLADE</b> - Flexible smoothing blade	<b>25 CM</b>
Ref. : 171855	<b>EDMABLADE</b> - Flexible smoothing blade	<b>35 CM</b>
Ref. : 171955	<b>EDMABLADE</b> - Flexible smoothing blade	<b>45 CM</b>
Ref. : 172055	<b>EDMABLADE</b> - Flexible smoothing blade	<b>60 CM</b>
Ref. : 172155	<b>EDMABLADE</b> - Flexible smoothing blade	<b>80 CM</b>
Ref. : 172255	<b>EDMABLADE</b> - Flexible smoothing blade	<b>100 CM</b>
Ref. : 271555	<b>EDMABLADE</b> - Handle	
Ref. : 169955	TELESCOPIC POLE	<b>1,20 - 2,40 M</b>
Ref. : 181355	PREMIUM JOINT KNIFE - Flexible blade	<b>10 CM</b>
Ref. : 181555	PREMIUM JOINT KNIFE - Flexible blade	<b>15 CM</b>
Ref. : 164355	MULTI PURPOSE TOOL	<b>8 CM</b>



**NEW**

## STORAGE CASE

**Lightweight and impact *resistant.***

Made of EVA and elastane.

Zip closure system with 2 sliders.

Zipped interior storage net.

Equipped with a handle for easy transport.

STORAGE CASE	S	XL
Ref.	743035	743036
Dimensions	650 x 250 x 90 mm	1350 x 350 x 100 mm

Storage case **S**



Storage case **XL**





Ref. : 271555

### EDMABLADE HANDLE

Allows the EDMABLADE smoothing blades to be connected to an EDMA pole.

Quick and easy fastening system.

Swivel head to adapt to the work support.

Ergonomics for an easy use without a pole.



### TELESCOPIC POLE

Aluminium head.

Flat, rotating and anti-slip handle tip.

DIMENSIONS	0,55 - 0,90 M	0,85 - 1,50 M	1,20 - 2,40 M
Ref.	179555	179655	169955





Ref. : 274055 **EDMALIGHT**

## CORDLESS LED SURFACE INSPECTION LIGHT

Powerful LED light for detecting imperfections and surface irregularities on walls and ceilings. Lightweight and wireless for optimal handling. Head tilts 100° and swivels 140° with anti-slip coating to adapt to the work surface.

### Adaptable to :

- EDMA tripod (not included)
- EDMA telescopic poles (not included, see page 73).

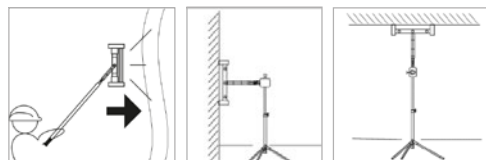

IP54



### SPECIFICATIONS

Power	7,5 W
Luminous flux	715 lm
LED L70B20	+ 30000 h of use
Colour of light source	6000 K = cool white
CRI	> 80 = good colour rendering
Grazing beam	30° x 10°

### Delivered with :

- Battery 14,8 V - Type 18650 - 2600 mAh - Li-ion
- Battery charger



Ref. : 274155

## EDMALIGHT COMPATIBLE TELESCOPIC TRIPOD

Steel.

Foldable feet.

Supplied with adapter for EDMALIGHT connection.

Compatible with any product with M8 thread.

### SPECIFICATIONS

Min. height	1,08 m
Max. height	2,80 m (reaches 3 m with the EDMALIGHT)





Ref. : 163355

## ANGULAR ABRASIVE SPONGE

**Grit 60**

Special for angles and corners.

Dimensions : 120 x 90 x 25 mm.



Ref. : 161255 **EASY LOCK SANDER**

## ABRASIVE HAND SANDER

Allows sanding and finishing of walls and ceilings.

No dust accumulation on the abrasive sheet.

Quick and easy abrasive sheet replacement.



Ref. : 161355 **EASY LOCK TELESCOPIC SANDER**

## ABRASIVE HAND SANDER ADAPTABLE TO A TELESCOPIC POLE

Allows to sand walls and ceilings without using scaffolding or step ladder.

Adjustable to EDMA telescopic poles (not included, see page 73).



### ABRASIVE MESH SANDING SHEET 290 X 100 MM

*No dust accumulation!*

Ref. : 163555

**Grit 80**

x10 pcs.

Ref. : 163655

**Grit 120**

x10 pcs.

Ref. : 163755

**Grit 240**

x10 pcs.



# CHOOSE YOUR EXPANSION TOOL



SPECIFICATIONS	BABY-FIX® BRICO	BABY-FIX® JUNIOR	FIX
Ref.	020155	021155	020355
Grips		✓	✓
Ratchet system			
Max. capacity Ø metal anchor	6 mm	8 mm	8 mm
Stroke length	18 mm	18 mm	19 mm
Support surface	100 x 20 mm	100 x 20 mm	20 x 29 mm
Difficult access			✓



SPECIFICATIONS	SUPER-FIX®	SUPRA-FIX®	ULTRA-FIX®
Ref.	021355	023155	023255
Grips	✓	✓	✓
Ratchet system			✓
Max. capacity Ø metal anchor	8 mm	8 mm	8 mm
Stroke length	19 mm	20 mm	30 mm
Support surface	22 x 27 mm	20 x 20 mm	20 x 20 mm
Difficult access	✓	✓	



## EXPANSION TOOLS FOR METAL ANCHORS



Ref. : 020155

### **BABY-FIX® BRICO**

Double hinge.  
Anti finger pinch.  
Support surface : 100 x 20 mm.  
Stroke length : 18 mm.  
Sprung handles.

**Max. capacity: ø 6 mm.**

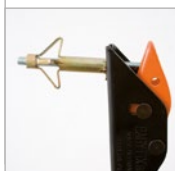

Ref. : 021155

### **BABY-FIX® JUNIOR**

Double hinge.  
Hardened steel arms and jaws.  
Support surface : 100 x 20 mm.  
Stroke length : 18 mm.  
Sprung handles.

**Max. capacity : ø 8 mm.**



Ref. : 020355

### **FIX**

Direct setting along the line of the hole.  
Can be used with minimum effort.  
Special for difficult access areas.  
Support surface : 20 x 29 mm.  
Stroke length : 19 mm.  
Sprung handles.

**Max. capacity : ø 8 mm.**





Ref. : 021355

**SUPER-FIX®**

Angled head to expand metal anchors in corners in one easy action.

Easy to use in confined spaces.

Support surface : 22 x 27 mm.

Stroke length : 19 mm.

Sprung handles.

**Max. capacity :  $\varnothing$  8 mm.**



Ref. : 023155

**SUPRA-FIX®**

Easy to use in corners.

Compact.

Support surface : 20 x 20 mm.

Increased stroke length : 20 mm.

Sprung handles.

**Max. capacity :  $\varnothing$  8 mm.**



Ref. : 023255

**ULTRA-FIX®**

**5 notches ratchet action.**

**Specially designed for effortless use with  $\varnothing$  8 mm metal anchors.**

Easy handle release system.

Support surface : 20 x 20 mm.

Exceptional stroke length : 30 mm.

Sprung handles.

**Max. capacity :  $\varnothing$  8 mm.**





Ref. : 070055 **MULTI-COUP®**

## MITRE SHEAR FOR VARIABLE CORNERS AND ANGLES

Fast, *neat* and effortless cutting.

Steel blade guard.

Interchangeable utility blade.

### IDEAL TO CUT THE FOLLOWING MATERIALS :

- Plastic sections
- Rubber glazing joints
- PVC decorative mouldings
- PVC tiling edging trim
- PVC tape



Ref. : 199255  
**TRAPEZE BLADE FOR CUTTER**  
x 10 pcs.

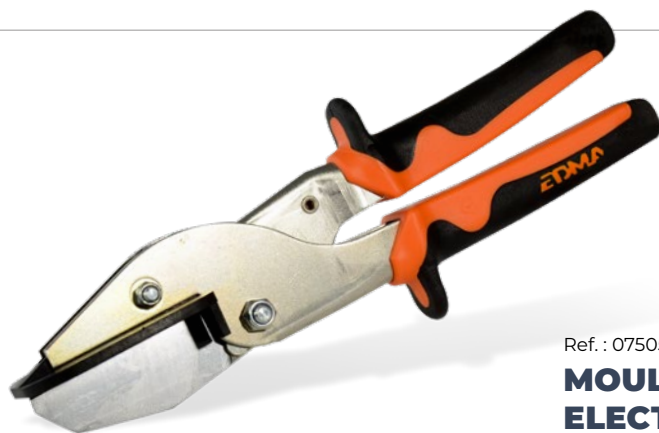

Ref. : 075055 **PLURI COUP EXTRA**

## MOULDINGS AND PVC ELECTRIC BASEBOARDS CUTTING PLIERS

65 mm blade which can be sharpened.

Cuts at 90°.

Cuts up to 40 x 10 mm.



Ref. : 071155  
**STAINLESS STEEL BLADE 65 MM**  
Re-sharpenable single-block blade.





Ref. : 170055

## MULTI COUP BOX

### SHEARS WITH 4 INTERCHANGEABLE BASES :

- **65 mm flat cutting base :**  
PVC electric baseboards, cords, rubber, cardboard, etc.
- **Mitre cutting base :**  
Flat surfaces and quarter round of wood or composite, decorative molding, PVC profiles for tile finishing, rubber seals, etc.

• **Cutting base for cutting 16 mm and 20 mm pipes :** for IRL, ICTA, PVC pipes.

• **Cutting base for cutting 45 x 25 mm wire duct.**

Clean cut without any distortion.  
No need to deburr : time-saving.  
65 mm stainless steel blade, interchangeable, can be sharpened.  
Carrying case included.

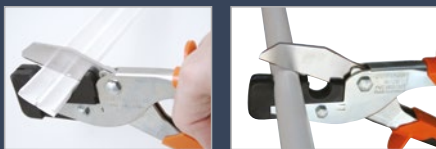

Ref. : 260655

## HAND AND SURFACE CLEANING WIPE

x 90 pcs

### No rinsing, drying or residue.

Safe for the epidermis, the wipe has a strong cleaning and detergent power.  
Effective on hands as well as on smooth, non-porous surfaces such as worktops, tools, machines, computers, copiers/fax, whiteboards, car interiors, wheel rims.  
Removes ordinary dirt as well as hard greases, fresh paints, adhesives, oils, lubricants, sludge, inks, waxes, bitumen, tar and other stubborn stains such as coal, graphite and grass marks.

**Composition :** vegetable solvents combined with an abrasive towel, which does not scratch.  
Classified in cosmetic products.

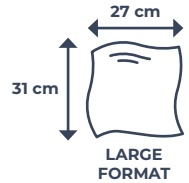

Program listed  
A1-A8-E4  
(Registration  
#147279).



# Painter Range

## **SURFACE PREPARATION AND PRECISION FINISHING**

EDMA's range of specific tools for painters is designed to give users a real time and effort saving on daily work.

Find out the entire range of must have specific tools to create your paintings and carry out your touch-ups for perfect completion.





Ref. : 274055

**EDMALIGHT**

## CORDLESS LED SURFACE INSPECTION LIGHT

Powerful LED light for detecting imperfections and surface irregularities on walls and ceilings. Lightweight and wireless for optimal handling. Head tilts 100° and swivels 140° with anti-slip coating to adapt to the work surface.

### Adaptable to :

- EDMA tripod (not included)
- EDMA telescopic poles (not included, see page 98).

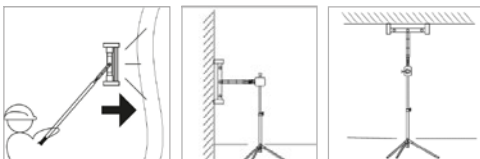

IP54



### SPECIFICATIONS

Power	7,5 W
Luminous flux	715 lm
LED L70B20	+ 30000 h of use
Colour of light source	6000 K = cool white
CRI	> 80 = good colour rendering
Grazing beam	30° x 10°

### Delivered with :

- Battery 14,8 V - Type 18650 - 2600 mAh - Li-ion
- Battery charger



Ref. : 274155

## EDMALIGHT COMPATIBLE TELESCOPIC TRIPOD

Steel.

Foldable feet.

Supplied with adapter for EDMALIGHT connection.

Compatible with any product with M8 thread.

### SPECIFICATIONS

Min. height	1,08 m
Max. height	2,80 m (reaches 3 m with the EDMALIGHT)





Ref. : 277855

## TRIANGULAR PAINTER'S SCRAPER

Allows to dig, to widen the cracks in the wall or the ceiling before filling.

Replaceable stainless steel blade, 3 mm thick.  
Long bi-material handle usable with 2 hands.



Ref. : 527781  
**SPARE BLADE**



Ref. : 277955

## PRECISION SCRAPER + 7 BLADES

Multi-purpose thanks to its blades of different shapes and sizes. 4 tungsten carbide blades ideal for meticulous, precise work, such as window frames, skirting boards but also places that are difficult to access.

3 stainless steel blades for stripping paint, varnish, compound on different shapes.

6-blade case for easy storage.

Ergonomic bi-material handle for a comfortable grip.

Delivered with a belt holster for storage.



Ref. : 527791  
**SPARE BLADE**  
x 6 pcs.



Ref. : 527782  
**SPARE TRIANGULAR BLADE**



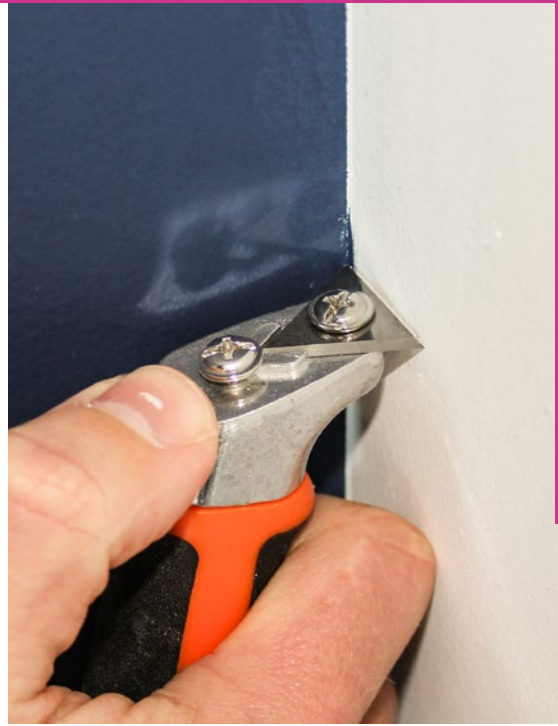

Ref. : 164355

## MULTI PURPOSE TOOL

8 cm

Stainless steel blade.  
Bi-material handle with metal head.

Stainless  
steel  
blade



### FEATURES :

- Joint knife
- Unmasking knife
- Filling knife/crack cleaner
- Nail puller and hammer
- Paint can opener
- Roller cleaner
- Scraper
- Rasp
- Cutter
- 11 mm (1/4") wrench
- 14 mm (3/8") wrench
- Bottle opener

Ref. : 164555

## HEAVY DUTY SCRAPER

8 cm

Striking scraper, *adjustable* to a pole.  
Stainless steel blade.

Bi-material handle with metal head.  
Compatible with EDMA telescopic poles  
(not included, see page 98).

Stainless  
steel  
blade





Ref. : 283055 **NEW**

## GRADUATED MULTIFUNCTION BUCKET 33 l

Versatile = allows mixing, transporting, storing, distributing...

Integrated graduations (from 5 to 24 l) for dosing glue preparations, jointing, compound, mortars.

Convenient to use thanks to its metal handle and its 2 side handles.

Easy to clean.

Transparent lid sold separately (ref. 528300).

### SPECIFICATIONS

Material	PP
Upper outer diameter	380 mm
Upper inner diameter	357 mm
Lower outer diameter	322 mm
Height	370 mm
Volume to the top edge	33 l



Ref. : 528300

## TRANSPARENT LID

For 33 l graduated  
multifunction bucket

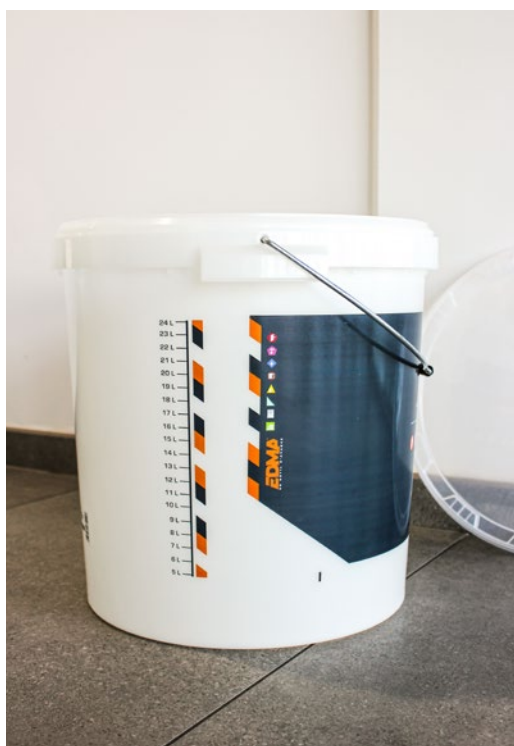

Stainless  
steel  
blade



Ref. : 276755

## BUCKET SCOOP KNIFE

**Allows to scrape/clean to the bottom of the bucket = avoids waste.**

Curved stainless steel blade facilitates the taking of compound.

Blade with a 13 cm radius and 16,5 cm width adapted to large buckets of compound.

Equipped with a hook to put the knife on the bucket.

Ideal for filling the EDMAPLIC drywall taper. Bi-material handle with metal head.



PAINTER



# PREMIUM JOINT KNIFE

Single material, in stainless steel = *more resistant.*  
Mirror-finish blade.



PREMIUM JOINT KNIFE	4 CM	5 CM	6 CM	8 CM	10 CM	12 CM	15 CM	20 CM	25 CM
Flexible blade (Ref.)	181055	--	181155	181255	181355	181455	181555	182055	182155
Stiff blade (Ref.)	181655	181755	--	181855	181955	--	--	--	--

**Flexible blade**

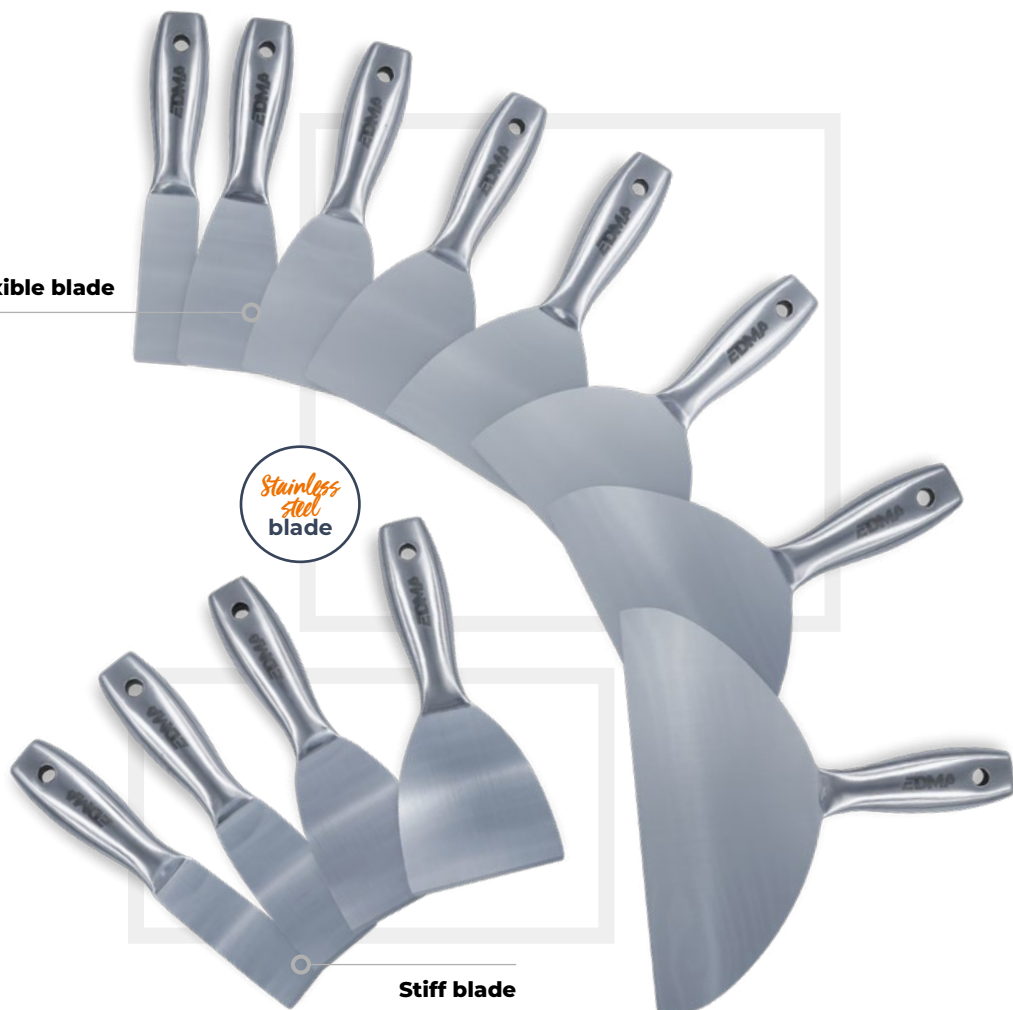

**Stiff blade**



Ref. : 610161

## SET OF PREMIUM JOINT KNIVES + STORAGE POUCH

### COMPOSED OF

Ref. : 181055	PREMIUM JOINT KNIFE Flexible blade	4 CM
Ref. : 181355	PREMIUM JOINT KNIFE Flexible blade	10 CM
Ref. : 181455	PREMIUM JOINT KNIFE Flexible blade	12 CM
Ref. : 181555	PREMIUM JOINT KNIFE Flexible blade	15 CM
Ref. : 182055	PREMIUM JOINT KNIFE Flexible blade	20 CM
Ref. : 164355	MULTI PURPOSE TOOL	8 CM
Ref. : 280255	STORAGE POUCH for joint knives	



## JOINT KNIFE WITH ROUNDED BLADE

0,5 mm thick stainless steel blade.  
 Rounded blade allowing to stay flat on the surface to work.  
 Reinforcement stiffening the blade over its entire width.  
 Bi-material handle with metal head.

JOINT KNIFE WITH ROUNDED BLADE									
	10 CM	12 CM	14 CM	16 CM	18 CM	20 CM	22 CM	24 CM	30 CM
Ref.	277055	277155	277255	277355	277455	277555	277655	277755	278255





Ref. : 167055

## CORNER COATING KNIFE

Stainless steel blade.  
Ideal to spread compound in inaccessible areas.  
Bi-material handle with metal head.



Ref. : 167955

## HALF ROUND KNIFE

Stainless steel blade.  
Ideal to spread compound in angles.  
Bi-material handle with metal head.

**EDMABLADE**

**SMOOTHING BLADE**

Allows smoothing of compounds, drywall tapes, plaster.  
 Easy to use thanks to its light and ergonomic structure.  
 Stainless steel blade with rounded edges for a result without  
 trace or loss of compound.

EDMABLADE	15 CM	25 CM	35 CM	45 CM	60 CM	80 CM	100 CM
Flexible blade (Ref.)	171655	171755	171855	171955	172055	172155	172255
Stiff blade (Ref.)	371655	371755	371855	371955	372055	372155	372255

**Flexible blade**

Blade thickness : 0,3 mm.

**Stiff blade**

Blade thickness : 0,5 mm.

Adaptable to EDMA telescopic poles (handle and poles not included, see page 98).

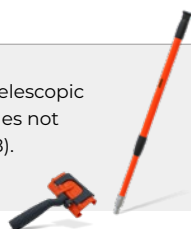



Ref. : 610190 **NEW**

# SET OF EDMABLADE S

## COMPOSED OF

Ref. : 743035	STORAGE CASE	S
Ref. : 171755	EDMABLADE - Flexible smoothing blade	25 CM
Ref. : 171855	EDMABLADE - Flexible smoothing blade	35 CM
Ref. : 171955	EDMABLADE - Flexible smoothing blade	45 CM
Ref. : 172055	EDMABLADE - Flexible smoothing blade	60 CM
Ref. : 271555	EDMABLADE - Handle	
Ref. : 179555	TELESCOPIC POLE	0,55 - 0,90 M
Ref. : 181555	PREMIUM JOINT KNIFE - Flexible blade	15 CM



Ref. : 610191 **NEW**

## SET OF EDMABLADE **XL**

### COMPOSED OF

Ref. : 743036	STORAGE CASE	<b>XL</b>
Ref. : 171655	<b>EDMABLADE</b> - Flexible smoothing blade	<b>15 CM</b>
Ref. : 171755	<b>EDMABLADE</b> - Flexible smoothing blade	<b>25 CM</b>
Ref. : 171855	<b>EDMABLADE</b> - Flexible smoothing blade	<b>35 CM</b>
Ref. : 171955	<b>EDMABLADE</b> - Flexible smoothing blade	<b>45 CM</b>
Ref. : 172055	<b>EDMABLADE</b> - Flexible smoothing blade	<b>60 CM</b>
Ref. : 172155	<b>EDMABLADE</b> - Flexible smoothing blade	<b>80 CM</b>
Ref. : 172255	<b>EDMABLADE</b> - Flexible smoothing blade	<b>100 CM</b>
Ref. : 271555	<b>EDMABLADE</b> - Handle	
Ref. : 169955	TELESCOPIC POLE	<b>1,20 - 2,40 M</b>
Ref. : 181355	PREMIUM JOINT KNIFE - Flexible blade	<b>10 CM</b>
Ref. : 181555	PREMIUM JOINT KNIFE - Flexible blade	<b>15 CM</b>
Ref. : 164355	MULTI PURPOSE TOOL	<b>8 CM</b>





Ref. : 271555

### EDMABLADE HANDLE

Allows the EDMABLADE smoothing blades to be connected to an EDMA pole.  
 Quick and easy fastening system.  
 Swivel head to adapt to the work support.  
 Ergonomics for an easy use without a pole.

### TELESCOPIC POLE

Aluminium head.  
 Flat, rotating and anti-slip handle tip.

DIMENSIONS	0,55 - 0,90 M	0,85 - 1,50 M	1,20 - 2,40 M
Ref.	179555	179655	169955







**NEW**

## STORAGE CASE

**Lightweight and impact resistant.**

Made of EVA and elastane.

Double zip closure system.

Zipped interior storage net.

Equipped with a handle for easy transport.

STORAGE CASE	S	XL
Ref.	743035	743036
Dimensions	650 x 250 x 90 mm	1350 x 350 x 100 mm

Ref. : 260655

## HAND AND SURFACE CLEANING WIPE

x 90 pcs

**No rinsing, drying or residue.**

Safe for the epidermis, the wipe has a strong cleaning and detergent power.

Effective on hands as well as on smooth, non-porous surfaces such as worktops, tools, machines, computers, copiers/fax, whiteboards, car interiors, wheel rims.

Removes ordinary dirt as well as hard greases, fresh paints, adhesives, oils, lubricants, sludge, inks, waxes, bitumen, tar and other stubborn stains such as coal, graphite and grass marks.

**Composition :** vegetable solvents combined with an abrasive towel, which does not scratch. Classified in cosmetic products.

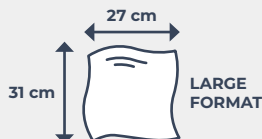

Program listed  
A1-AB-E4  
(Registration  
#147279).



# TILER RANGE

## PRECISION CUTTING, EASY INSTALLATION

EDMA's range of specific tools for tiler is designed to give users a real time and effort saving on daily work.

Find out the entire range of must have specific tools on laying tiles and mosaics application.

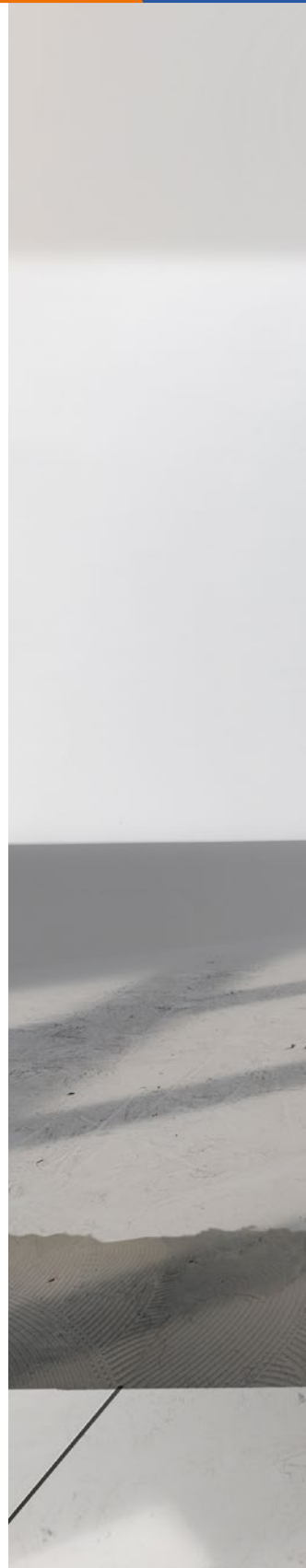





CE

Ref. : 259755

## GEL KNEE PADS

**Comfortable and *resistant.***

Soft nylon shell.

Breathable SBR neoprene fabric.

Injected foam and gel padding for maximum comfort.

Double adjustable straps with buckles = easy adjustment, no shearing effect.

Ideal to protect your knees from hard surfaces such as cement, overall floor coverings or roofs.

CE certified.

EN14404: 2004+A1: 2010 - Type 1 level 1.

CE

Ref. : 259855

## GEL KNEE PADS WITH STABILIZING REINFORCEMENT

***Optimal* stability and protection thanks to TPR reinforcements.**

Breathable SBR neoprene fabric.

Injected foam and gel padding for maximum comfort.

Double adjustable straps with buckles = easy adjustment, no shearing effect.

Ideal to protect your knees from hard surfaces such as cement, overall floor coverings or roofs.

CE certified.

EN14404: 2004+A1: 2010 - Type 1 level 1.



Ref. : 258555

## ROLLER KNEE SUPPORTS

**Lightweight and *comfortable* for optimal mobility.**

Ideal for laying all types of flooring.  
 360° rotation thanks to its 3 wheels, allowing quick movements without leaving marks.  
 Gel cushion for more comfort.  
 Straps reduce tension behind the knee.  
 Close to the floor to avoid premature back fatigue.  
 Possibility to remove the wheeled base by pressing a button.



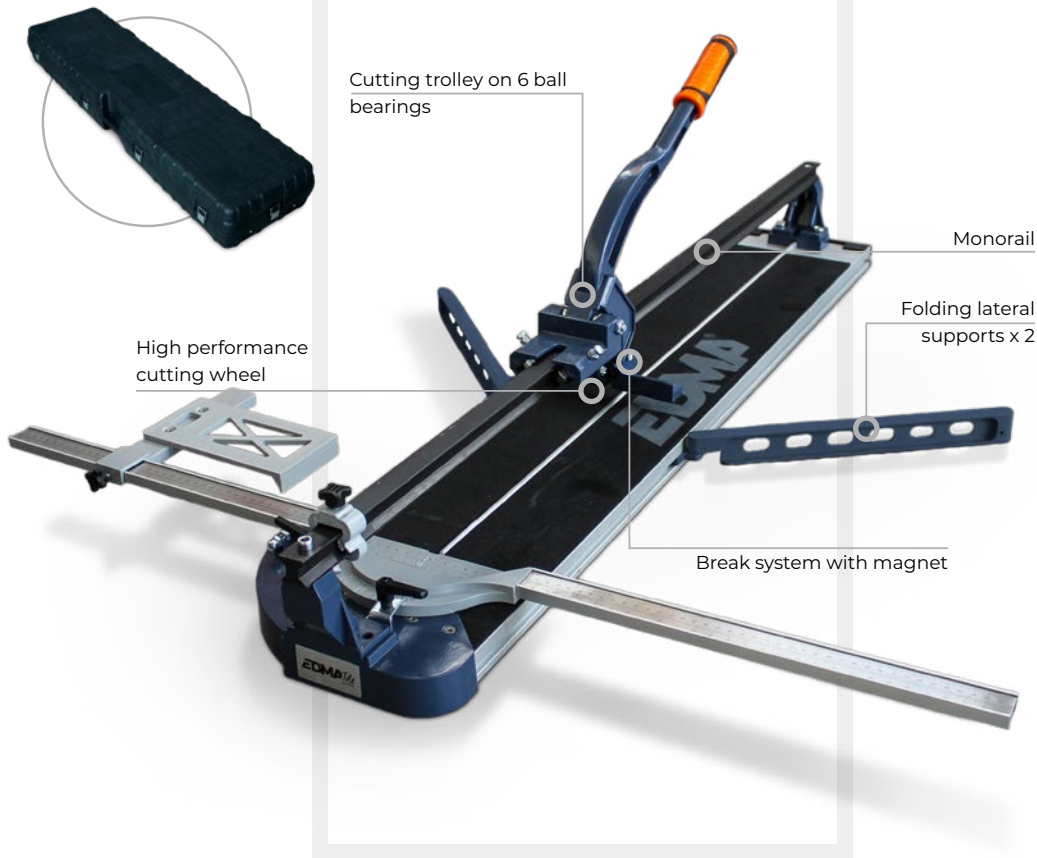

Cutting trolley on 6 ball bearings

Monorail

Folding lateral supports x 2

High performance cutting wheel

Break system with magnet

**EDMATILE**

## MONORAIL TILE CUTTER



### Fast and precise *cutting.*

For straight and angled cuts up to 45°.

Cutting trolley on 6 ball bearings.

Aluminium base = lightweight tool.

Break system with magnet for easy handling.

2 different separators to adapt to the thickness of the tiles.

High performance tungsten carbide cutting wheel.

Graduated lateral supports with adjustable and swivelling stop.

Folding lateral supports.

Ergonomic handle.

Carrying bag included.

EDMATILE	650	950	1350
Carrying bag (Ref.)	251055	251155	251255
Carrying bag + case (Ref.)	251001	251101	251201
Max. cutting thickness	20 mm	20 mm	20 mm
Max. tile size / straight cut	650 x 650 mm	950 x 950 mm	1350 x 1350 mm
Max. tile size / diagonal cut	455 x 455 mm	670 x 670 mm	950 x 950 mm



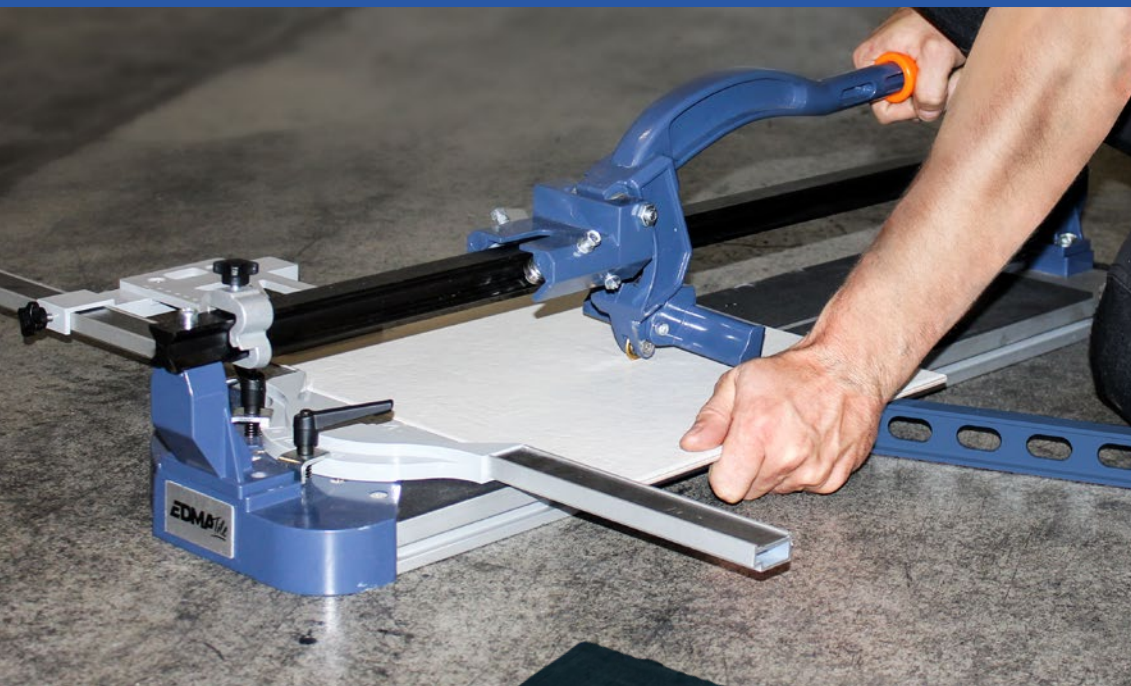

## CARRYING CASE

Transportation and storage in *all safety*.  
 Double thickness = rigid, shock-resistant.  
 Metal buckle closure.  
 With integrated handle.

CARRYING CASE	M	L	XL
Ref.	743021	743022	743023
EDMATILE model	<b>650</b>	<b>950</b>	<b>1350</b>
Outer dimensions	1030 x 390 x 250 mm	1330 x 390 x 250 mm	1730 x 390 x 250 mm
Inner dimensions	945 x 265 x 222 mm	1255 x 265 x 222 mm	1650 x 265 x 222 mm



### MAIN GAUGE

Ref. : 525101 For EDMATILE 650.  
 Ref. : 525104 For EDMATILE 950.  
 Ref. : 525105 For EDMATILE 1350.



Ref. : 525109  
**COMPLETE MAGNETIC CUTTING TROLLEY**  
 For EDMATILE 650, 950, 1350.



Ref. : 525100  
**BALL BEARING CUTTING WHEEL**  
 For EDMATILE and EDMATILE XXL.  
 Ø 22 x Ø 6 x 2 mm.

Ref. : 251355 **EDMATILE XXL**

## CUTTING SYSTEM FOR LARGE TILES

### COMPOSED OF

Push-on aluminium guides of 1100 mm	3
Aluminium suction cups	2
Trolley with cutting wheel	1
Separating pliers	2
Carrying bag	1

### SPECIFICATIONS

Max. cutting length	3000 mm
Max. cutting thickness	8 mm



Ref. : 525100

**BALL BEARING CUTTING WHEEL**  
For EDMATILE and EDMATILE XXL.  
Ø 22 x Ø 6 x 2 mm.

Ref. : 251455

## SCRIBE TIP

Enables to draw on tile and ceramic.  
Tungstene carbide point.  
Swivelling head = right-handed or left-handed use.  
Ergonomic handle.  
Can be used to scrub the seals.



Ref. : 251655

## TILE CUTTING PLIERS

Wheel and breaking system integrated.  
Handle spring.  
Bi-material ergonomic handle.

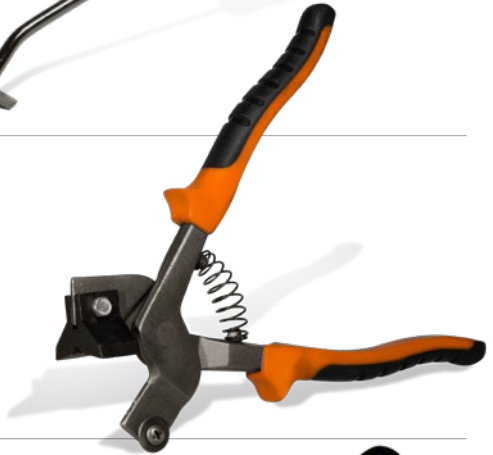

Ref. : 251755

## MOSAIC TILE CUTTING PLIERS

Enables to make small cuts and croppings.  
Deported tungsten carbide jaws.  
Handle spring.  
Bi-material ergonomic handles.



Ref. : 070055 **MULTI-COUP®**

## MITRE SHEAR FOR VARIABLE CORNERS AND ANGLES

**Fast, neat and effortless cutting.**  
Steel blade guard.  
Interchangeable utility blade.

**IDEAL TO CUT THE FOLLOWING MATERIALS :**

- Plastic sections
- Rubber glazing joints
- PVC decorative mouldings
- PVC tiling edging trim
- PVC tape



Ref. : 199255  
**TRAPEZE BLADE FOR CUTTER**  
x 10 pcs.



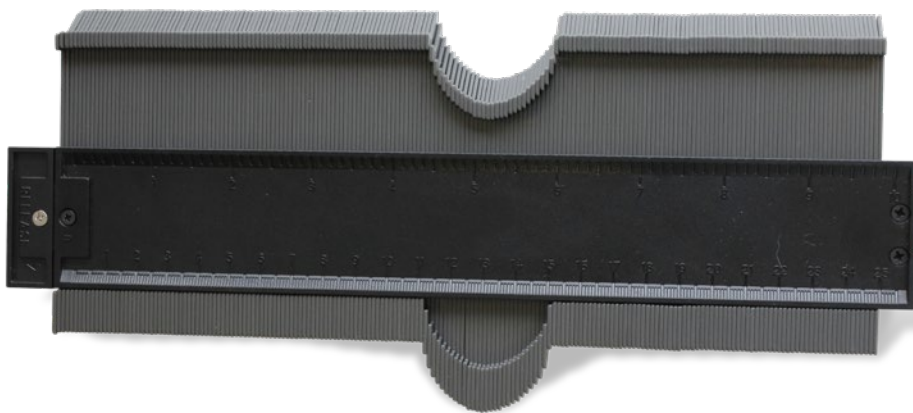

Ref. : 088255 **DUPLIC FORM**  
**CONTOUR GAUGE**  
**250 mm**

To match contours to be cut.  
 For plumbing pipes as well as mouldings  
 and so on.

**SPECIFICATIONS**

Width	250 mm
Depth	45 mm

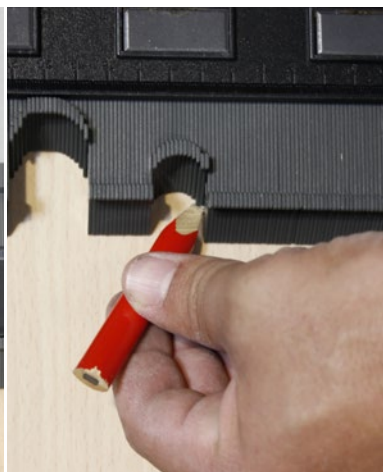
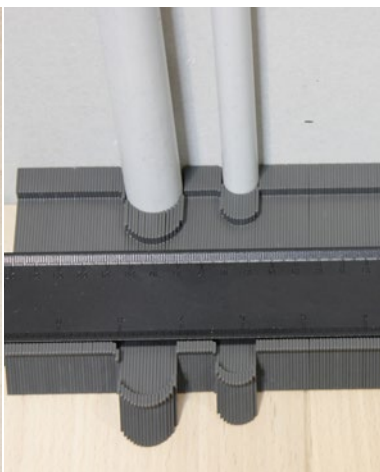





Ref. : 262055 **NEW**

## MULTI-ANGLE CONTOUR GAUGE

**With tracing templates Ø 25, 40, 45, 55 and 75 mm.**

Allows to quickly transfer and trace the location of a hole before drilling.

Equipped with 6 sliding segments of 175 mm in aluminium, graduated in cm and inch.

108 x 108 mm locator, including 5 templates of different diameters.

Foldable and easy to adjust thanks to its cross-shaped buttons in order to adapt to various angles and shapes.





## DRILL BIT

For water drilling of ceramics, stoneware and porcelain.

DRILL BIT	Ø 6 MM	Ø 8 MM	Ø 10 MM	Ø 12 MM	Ø 28 MM	Ø 35 MM	Ø 43 MM	Ø 68 MM	Ø 100 MM	Ø 120 MM
Ref.	272355	272455	272555	274255	274355	272655	272755	272855	272955	273055



## CORE DRILL

For dry drilling of ceramics, stoneware and porcelain.

Max. 14000 RPM.

CORE DRILL	Ø 6 MM	Ø 8 MM	Ø 10 MM	Ø 12 MM	Ø 28 MM	Ø 35 MM	Ø 40 MM	Ø 45 MM	Ø 65 MM	Ø 68 MM	Ø 100 MM	Ø 120 MM
Ref.	273155	273255	273355	274455	274555	273455	274655	273555	274755	273655	273755	273855





Ref. : 251955

## **BOX OF 8 DIAMOND DRILL BITS**

**Ø 6, 8, 10, 12, 28, 35, 43, 68 mm**

For water drilling of ceramics, stoneware and porcelain.



Ref. : 252055

## **BOX OF 10 DIAMOND CORE DRILLS**

**Ø 6, 8, 10, 12, 28, 35, 40, 45, 65, 68 mm**

For dry drilling of ceramics, stoneware and porcelain.

Max. 14000 RPM.

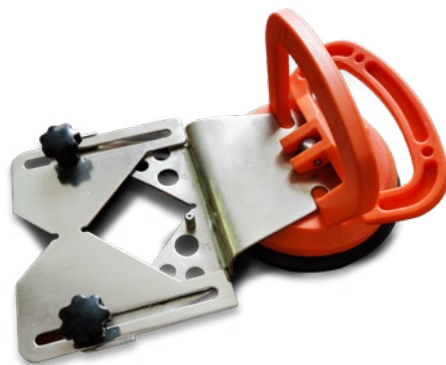

Ref. : 273955

## **DRILL GUIDE FOR DRILL BITS**

**Ø 6 to 84 mm**

Centring holes Ø 6, 8, 10 and 12 mm.

Max. capacity of the central guide: Ø 84 mm.

Easy adjustment and locking.

Allows optimum centring of the drill bit when drilling.

Can be fixed on the surface to be drilled thanks to its suction cup.

Equipped with connection for water cooling system.



Ref. : 258355

## ABRASIVE BLOCK

150 x 50 x 25 mm

Double grit : 120 and 240.

To sand, adjust, bevel the edges of the tiles.



Ref. : 283055 **NEW**

## GRADUATED MULTIFUNCTION BUCKET

33 l

Versatile = allows mixing, transporting, storing, distributing...

Integrated graduations (from 5 to 24 l) for dosing glue preparations, jointing, compound, mortars.

Convenient to use thanks to its metal handle and its 2 side handles.

Easy to clean.

Transparent lid sold separately (ref. 528300).

### SPECIFICATIONS

Material	PP
Upper outer diameter	380 mm
Upper inner diameter	357 mm
Lower outer diameter	322 mm
Height	370 mm
Volume to the top edge	33 l



Ref. : 528300

## TRANSPARENT LID

For 33 l graduated multifunction bucket





Ref. : 252155

## FLEXIBLE MIXING BUCKET 42 l

Ideal for glue preparation, jointing and transport of rubble.

Made of polyethylene.

Integrated graduations (liter and gallon).

Equipped with 2 handles for easy transport.

## MIXING PADDLE

Ref. : 254855

**Ø 100 mm**

SDS mounting.

Also

compatible

with

conventional

chucks.



Ref. : 254955

**Ø 120 mm**

Ref. : 255055

**Ø 140 mm**

M14 mounting.





Ref. : 257355

## MODULAR TRANSPORT CART

Light and *compact.*

EVA resin tray and retractable steel handle.

7 rubber wheels.

### SPECIFICATIONS

Extendable length	up to 70 cm
Dimensions	58 x 40 cm
Max. load	220 kg

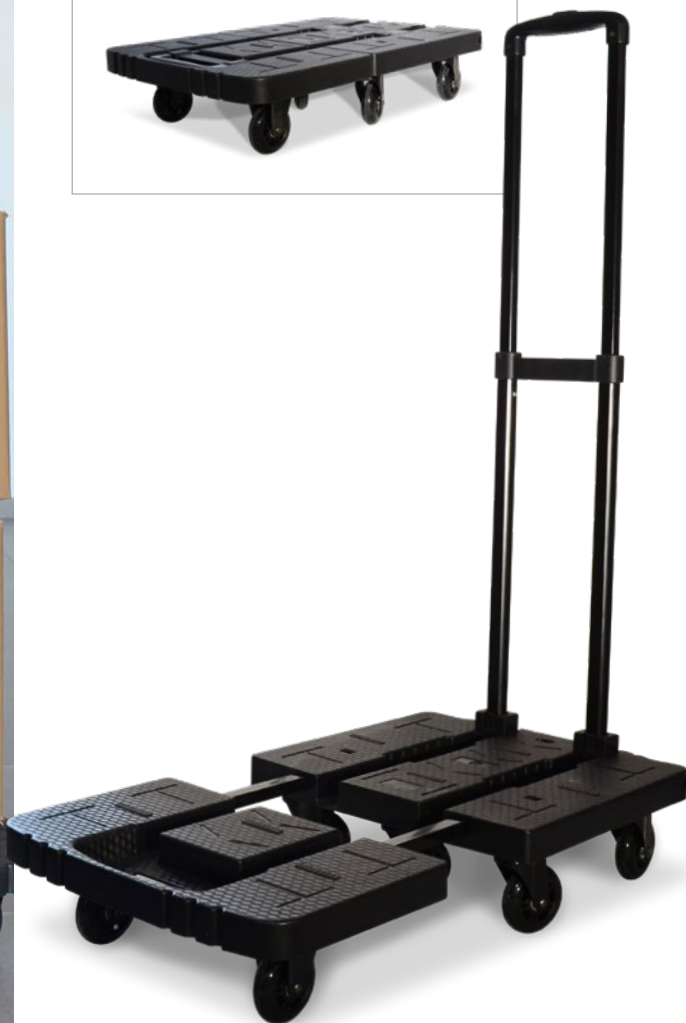

## TILE LIFTER

Quick adjustment system.  
Ideal to easily carry tiles.  
Centered handle whatever the width of tile to carry.

ADJUSTABLE FROM	280 TO 665 MM	280 TO 800 MM
Ref.	269055	369055
Max. carried load*	35 kg	50 kg

\* Test performed by **SGS** on a 40 cm x 40 cm tile.





## SUCTION CUP

Aluminium alloy.  
For smooth tiles and surfaces.



SUCTION CUP	SINGLE	DOUBLE	TRIPLE
Ref.	250155	250255	250355
Diameter	1 head Ø 120 mm	2 heads Ø 120 mm	3 heads Ø 120 mm
Max. capacity	40 kg	80 kg	120 kg

Ref. : 257255

## SINGLE VACUUM SUCTION CUP

Double lip.  
Equipped with a gauge to check the pressure = safety and reliability.  
With required pressure mark.  
Pressure release button and tab for easy removal.  
For smooth and rough surfaces.  
Carrying case and protective cover included.

### SPECIFICATIONS

Diameter	200 mm
Max. capacity	150 kg





Ref. : 269455 **NEW**

## CORDLESS ELECTRIC SUCTION CUP

Double lip.

Automatic on/off function : the pump stops when the required pressure is reached (-450 mmHg).

Automatic pressure regulation : if pressure drops below -350 mmHg, the pump switches on and draws vacuum again until -450 mmHg is reached.

Equipped with a gauge to check the pressure = safety and reliability.

Double-click ON/OFF button to release pressure and tab for easy removal.

Anti-slip handle.

For smooth and rough surfaces.

Carrying case and protective cover included.

CE certified.

### SPECIFICATIONS

Diameter	198 mm
Handle length	110 mm
Net weight	0,922 kg
Max. capacity	130 kg
Built-in battery	3,7 V - 900 mAh Li-ion
Rated power	3 W
Autonomy	approx. 8 h
Charging cable	USB C
Charging time	2 h



CE

## ACCESS PANEL TO BE TILED

Easy to install, invisible, easy to open.



DIMENSIONS	30 X 30 CM	40 X 40 CM
Ref.	257455	257555
Outer dimensions	309 x 309 mm	409 x 409 mm
Frame height	25,5 mm	25,5 mm

Ref. : 257655 **EDMAGNETIK**

## MAGNETIC SYSTEM FOR MAKING INSPECTION HATCHES

Quick and invisible installation.  
Composed of 4 legs with magnet and 4 magnetic plates.  
The tile becomes the hatch = custom-made.  
Max. adhesion power : 3 kg.

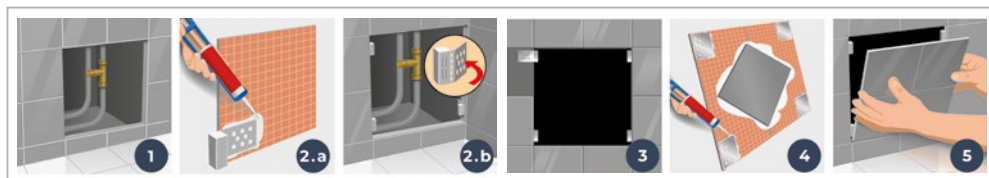

## WATERPROOF STAINLESS STEEL FLOOR HATCH

Double seal.  
Stainless steel.  
Opening keys included.

DIMENSIONS	30 X 30 CM	40 X 40 CM	60 X 60 CM
Ref.	257755	257855	257955
Outer frame height	50 mm	50 mm	50 mm





## NOTCHED SPREADER 300 mm



Stainless steel blade.

TEETH DIMENSIONS	4 X 4 MM	6 X 6 MM	8 X 8 MM	10 X 10 MM	HALF MOON 20 X 10 MM
Ref.	255155	255255	255355	255455	255555



## NOTCHED TROWEL 280 mm

Stainless steel blade.

Fiberglass-reinforced polyamide frame = lightweight and durable.  
Ergonomic bi-material handle.

TEETH DIMENSIONS	4 X 4 MM	6 X 6 MM	8 X 8 MM	10 X 10 MM	<b>N</b> 12 X 12 MM	10 X 10 MM 45°	HALF MOON 20 X 10 MM
Ref.	258655	255655	255755	255855	260755	255955	259455

Ref. : 256055

## MARGIN TROWEL 80 mm

Stainless steel blade.  
Bi-material ergonomic handle.



## SINGLE-USE TILE SPACER

Enables to make steady  
spacing between tiles.  
In bag.



## RECOVERABLE TILE SPACER

**Reusable**  
Enables a steady  
aligning of tiles.  
In bag.



THICKNESS	1,5 MM	2 MM	2,5 MM	3 MM	4 MM	5 MM	
<b>SINGLE USE</b> (Ref. / Qty)	252355	252455	262255 <b>N</b>	---	252555	262355 <b>N</b>	252655
	x 300 pcs	x 300 pcs	x 1000 pcs		x 200 pcs	x 1000 pcs	x 200 pcs
<b>REUSABLE</b> (Ref. / Qty)	252755	252855	252955	253055	253155	253255	
	x 100 pcs	x 100 pcs	x 100 pcs	x 75 pcs	x 50 pcs	x 40 pcs	

Consumption table (for information)

Tile dimensions	10x10	15x15	20x20	30x30	40x40	45x45	50x50	60x30	60x60
Necessary tile spacers/m <sup>2</sup>	100	49	25	16	9	9	4	8	4

Ref. : 253955

## TILE WEDGE 5 mm - x 500 pcs

Dimensions : 30 x 6 mm.  
Thickness from 1 to 5 mm.  
In bag.





**NEW**

## PREMIUM MULTIPURPOSE MALLET

Multi-angle head with chamfered edges for easy positioning of flooring without damaging it.

Avoids traces.

Ergonomic, anti-slip handle.

### PREMIUM MALLET

**250 G**

**500 G**

Ref.

261855

261955



TILER



## MARKLESS MALLET

1 spherical face and 1 flat face.

To position the tile and facilitate its adhesion.

Avoids traces.

### MARKLESS MALLET

**250 G**

**500 G**

Ref.

254055

254155

**EDMALEVEL**

**SELF-LEVELLING SYSTEM**

Quick and easy *installation.*

Eliminates level differences and maintains a constant joint width.



**STARTING KIT**

**100 pcs**

Allows tiles from 3 to 13 mm thick to be laid and levelled. In bucket.

STARTING KIT	1,5 MM	2 MM
Ref.	259255	259355
Composed of	- 1 adjusting pliers - 100 tile spacers of 1.5 mm - 100 wedges	- 1 adjusting pliers - 100 tile spacers of 2 mm - 100 wedges





Ref. : 254555

## ADJUSTING PLIERS

Double die for wide or narrow spacers.

Adjustable spacing.

Stop screw allowing a steady pressure during serial laying.

Ergonomic bi-material handle.

Removable plastic stops.

## TILE SPACER

Resistant.

Clear break at the base of the foot for an invisible result.



**THICKNESS / QUANTITY**

1 MM

1,5 MM

2 MM

3 MM

**Tile spacer for laying and levelling tiles from 3 to 13 mm thick.**

250 pcs in bag

---

258955

259055

---

500 pcs in bag

276655

258855

258055

258155

1000 pcs in bucket

---

283455 N

283555 N

---

**XL tile spacer for laying and levelling tiles from 11 to 20 mm thick.**

250 pcs in bag

---

259555

259655

---



Ref. : 258255

## TILE WEDGE x 250 pcs

Dimensions : 91 x 23 mm.

Thickness from 2 to 18 mm.

Toothed.

Reusable.

In bag.

**Consumption table** (for information)

pcs / m<sup>2</sup>

X	15	20	25	30	33	40	50	60	75	90	100	120	150	180	200	240	300	Y
15	89																	
20	67	50																
25	53	40	32															
30	67	50	40	44														
33	61	45	36	40	37													
40	50	38	30	25	31	25												
50	40	30	24	27	24	20	16											
60	33	25	20	22	20	17	13	11										
75	33	25	20	21	19	17	12	10	9									
90	30	22	18	15	15	11	9	8	7									
100	33	25	20	15	15	12	10	9	8	8								
120	28	21	17	15	15	10	8	7	6	7	6							
150	27	20	16	15	15	10	8	8	6	6	5	5						
180	26	20	16	13	14	12	9	8	7	9	6	5	5	4				
200	27	20	16	14	14	12	9	8	7	6	6	5	4	4	4			
240	25	19	15	13	13	11	9	7	7	6	5	5	4	4	4	3		
300	37	25	19	15	13	10	9	8	7	5	5	4	4	3	3	3	3	
	15	20	25	30	33	40	50	60	75	90	100	120	150	180	200	240	300	Y

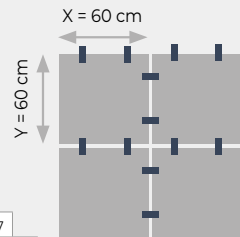

**EDMA LEVEL SCREW** NEW

## SELF-LEVELLING SYSTEM

*Self-screwing* = quick and easy installation.

Eliminates level differences and maintains a constant joint width.

Allows tiles from 3 to 20 mm thick to be laid and levelled.

Innovative = break the spacer in any direction.

Clear break at the base of the foot for an invisible result.

Transparent clamping head for better visibility of the work.

Does not mark the tile, does not damage it.

NEW

### STARTING KIT

For all types of installations.  
In bucket.



STARTING KIT	1 MM	2 MM
Ref.	282055	282155
Composed of	- 100 linear spacers 1 mm - 50 clamping heads	- 100 linear spacers 2 mm - 50 clamping heads













**NEW**

**SELF-LEVELLING SYSTEM**

**Linear spacer**

x 200 pcs.

For all types of installations.  
In bag.

	1 MM	2 MM	3 MM	
<p><b>Linear spacer</b> x 200 pcs.</p> <p>For all types of installations. In bag.</p>	 Ref. : 281055	 Ref. : 281355	 Ref. : 281655	
<p><b>Cross spacer</b> x 200 pcs.</p> <p>For straight, diagonal installations and cross joints. In bag.</p>	 Ref. : 281155	 Ref. : 281455	 Ref. : 281755	
<p><b>T-Spacer</b> x 200 pcs.</p> <p>For herringbone, Roman opus, parquet, offset joints, cross joints. In bag.</p>	 Ref. : 281255	 Ref. : 281555	 Ref. : 281855	
<p><b>Clamping head</b> x 50 pcs.</p> <p>Ergonomic design for optimal handling. Reusable. In bag.</p>				 Ref. : 281955



Ref. : 256355 **EDMACLEAN**

## 24 L TILE JOINT KIT + ACCESSORIES

For cleaning and grouting tiles.

### COMPOSED OF

Bucket of 24 L graduated	1
Removable wheels, 2 of which with brakes	4
Removable perforated spin rollers	2
Cleaning grid	1
Sponge float	1
Medium grout float	1





## GROUT SPREADER

Allows to pour and clean the joints.

GROUT SPREADER	200 MM	300 MM
Ref.	256155	256255

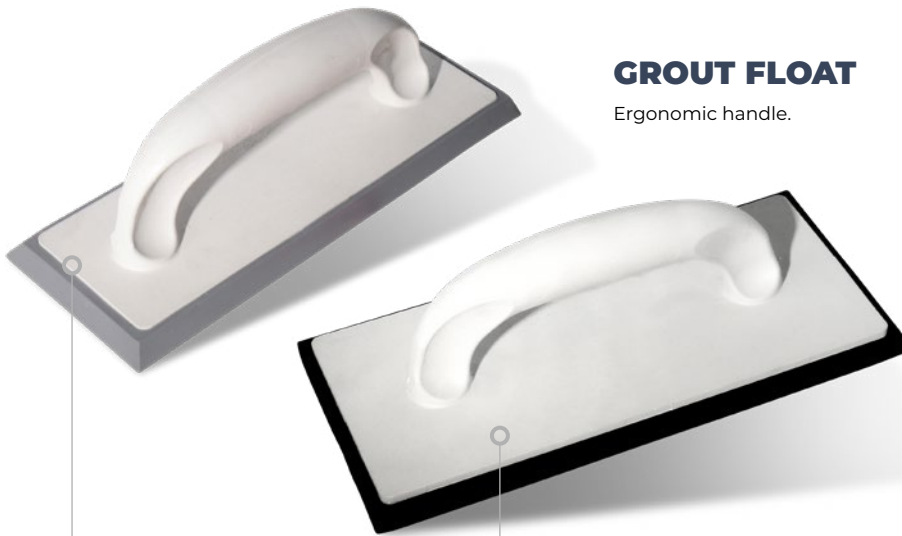

## GROUT FLOAT

Ergonomic handle.

Ref. : 256455

**Hard - 250 x 100 mm**

For epoxy joints.  
Bevelled edges.

Ref. : 256555

**Medium - 270 x 130 mm**

## TILE SPONGE



Ref. : 254255  
**200 x 100 x 60 mm**  
 1 abrasive side and  
 1 absorbent side.



Ref. : 258455  
**190 x 130 x 50 mm**  
 Rounded edges.



## SPONGE FLOAT

Thickness 30 mm.  
 Ergonomic handle.

Ref. : 257155  
**Cutted - 280 x 140 mm**  
 Optimized efficiency.

Ref. : 257055  
**280 x 140 mm**





Ref. : 256655

## CLEANING FLOAT

### Self-gripping

Allows to clean tiles and joints.

#### COMPOSED OF

Plastic support with ergonomic handle	1
Hard abrasive self-gripping pad 250 x 100 mm	1
Soft abrasive self-gripping pad 250 x 100 mm	1

#### SPARE PAD - 250 X 100 MM



Ref. : 256755

*Self-gripping*  
**Soft abrasion x 1 pc +  
hard abrasion x 1 pc.**



Ref. : 256855

**Soft abrasion x 2 pcs.  
Ideal for cleaning.**



Ref. : 256955

**Hard abrasion x 2 pcs.  
Ideal for stripping.**





## FLOOR SQUEEGEE

Enables to clean and grout.  
Double foam.  
Reinforced bush  $\varnothing$  24 mm.

DIMENSIONS	55 CM	75 CM
Ref.	254355	259955



Ref. : 254655

## CLEANING BRUSH + SQUEEGEE

**42 cm**

2 in 1.  
Double row of hard hair.  
Adaptable on EDMA telescopic poles  
(not included, see page 98).



Ref.: 254755

## GROUT SAW

Use with 1 or 2 blade(s).

Supplied with 2 tungsten carbide blades :  
1 set on the tool, the additional one within the storage compartment.



Ref.: 525470  
SPARE BLADE

Ref.: 260655

## HAND AND SURFACE CLEANING WIPE

x 90 pcs

**No rinsing, drying or residue.**

Safe for the epidermis, the wipe has a strong cleaning and detergent power.

Effective on hands as well as on smooth, non-porous surfaces such as worktops, tools, machines, computers, copiers/fax, whiteboards, car interiors, wheel rims.

Removes ordinary dirt as well as hard greases, fresh paints, adhesives, oils, lubricants, sludge, inks, waxes, bitumen, tar and other stubborn stains such as coal, graphite and grass marks.

**Composition :** vegetable solvents combined with an abrasive towel, which does not scratch.  
Classified in cosmetic products.

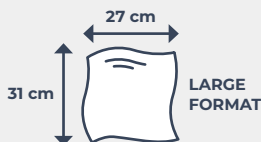

Program listed  
A1-AB-E4  
(Registration  
#147279).



# FLOORING INSTALLER RANGE

## **FAST CUTTING, PRECISE FITTING**

EDMA's range of specific tools for flooring installer is designed to give users a real time and effort saving on daily work.

Find out the entire range of must-have specific tools for laying laminate and vinyl floors.





FLOORING  
INSTALLER





CE

Ref. : 259755

### GEL KNEE PADS

**Comfortable and *resistant.***

Soft nylon shell.

Breathable SBR neoprene fabric.

Injected foam and gel padding for maximum comfort.

Double adjustable straps with buckles = easy adjustment, no shearing effect.

Ideal to protect your knees from hard surfaces such as cement, overall floor coverings or roofs.

CE certified.

EN14404: 2004+A1: 2010 - Type 1 level 1.

CE

Ref. : 259855

### GEL KNEE PADS WITH STABILIZING REINFORCEMENT

***Optimal* stability and protection thanks to TPR reinforcements.**

Breathable SBR neoprene fabric.

Injected foam and gel padding for maximum comfort.

Double adjustable straps with buckles = easy adjustment, no shearing effect.

Ideal to protect your knees from hard surfaces such as cement, overall floor coverings or roofs.

CE certified.

EN14404: 2004+A1: 2010 - Type 1 level 1.





Ref. : 258555

## ROLLER KNEE SUPPORTS

**Lightweight and *comfortable* for optimal mobility.**

Ideal for laying all types of flooring.  
360° rotation thanks to its 3 wheels, allowing quick movements without leaving marks.  
Gel cushion for more comfort.  
Straps reduce tension behind the knee.  
Close to the floor to avoid premature back fatigue.  
Possibility to remove the wheeled base by pressing a button.



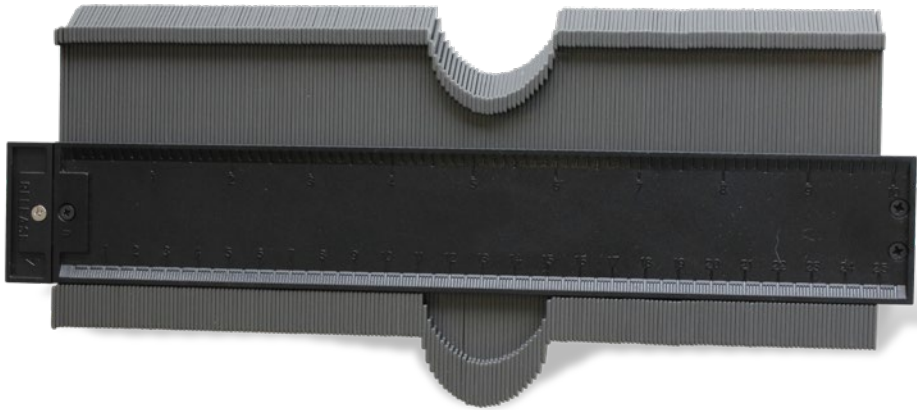

Ref. : 088255 **DUPLIC FORM**

## CONTOUR GAUGE

**250 mm**

To match contours to be cut.  
For plumbing pipes as well as mouldings  
and so on.

### SPECIFICATIONS

Width	250 mm
Depth	45 mm

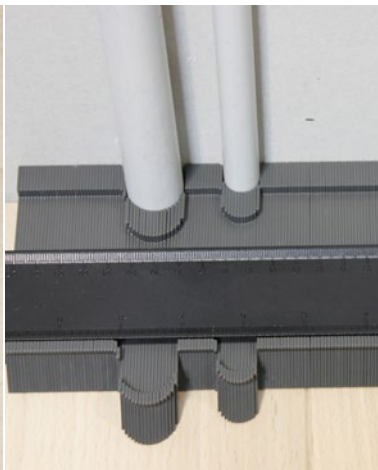



Ref. : 262055 **NEW**

## MULTI-ANGLE CONTOUR GAUGE

**With tracing templates Ø 25, 40, 45, 55 and 75 mm.**

Allows to quickly transfer and trace the location of a hole before drilling.

Equipped with 6 sliding segments of 175 mm in aluminium, graduated in cm and inch.

108 x 108 mm locator, including 5 templates of different diameters.

Foldable and easy to adjust thanks to its cross-shaped buttons in order to adapt to various angles and shapes.

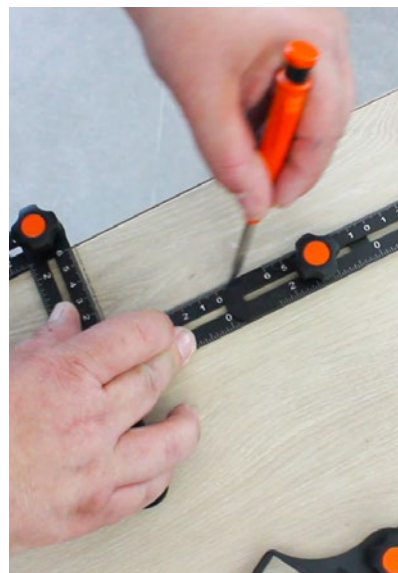
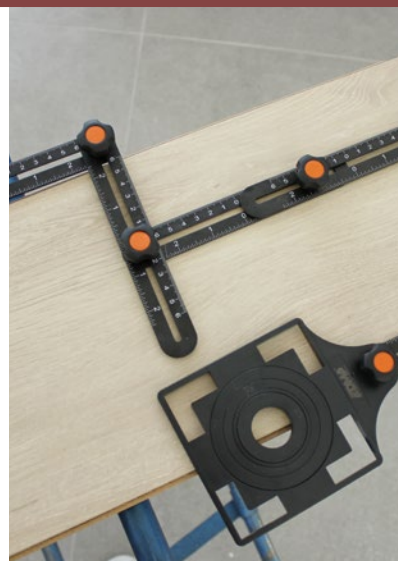

## CHOOSE YOUR FLOORING GUILLOTINE



SPECIFICATIONS	STRATICUT® 230 LVT	STRATICUT® 230	MEGA STRATICUT® 400
Ref.	089355	089055	289955
Flooring type	Laminate and vinyl	Laminate	Laminate
Max. width with stoppers	230 mm	230 mm	400 mm
Max. cutting thickness	12 mm	12 mm	15 mm
Angle cut	✓	✓	✓
Length cut	✓	✓	✓
Width cut	✓	✓	✓



Ref.: 089355 **STRATICUT® 230 LVT**  
**LAMINATE AND VINYL  
 FLOORING GUILLOTINE**

**Fast and *effortless* cutting.**

No breathable dust.

No noise.

No sharpening required ever on blade.

**Removable stoppers to make angle cuts, cuts in length and wider than 230 mm planks.**

Max. width with stoppers : 230 mm overall.

**Cutting die with 2 positions :**

- Position 1 (narrow die) : to cut LVT (Luxury Vinyl Tile), HD vinyl and PVC floorings up to 12 mm thick.

- Position 2 (wide die) : to cut laminate floorings up to 12 mm thick.

**Accessories :**

- 1 trestle.

- 1 dust collector.





Ref. : 089055 **STRATICUT® 230**

## LAMINATE FLOORING GUILLOTINE

**Fast and *effortless* cutting.**

No breathable dust.

No noise.

No sharpening required ever on blade.

**Removable stoppers to make angle cuts,  
cuts in length and wider than 230 mm  
planks.**

Max. width with stoppers : 230 mm overall.

Cutting capacity : max. 12 mm thickness.

**Accessories :**

- 1 trestle.

- 1 dust collector.







Ref. : 289955 **MEGA STRATICUT® 400**

## 400 MM LAMINATE FLOORING GUILLOTINE

**Fast and *effortless* cutting.**

No breathable dust.

No noise.

No sharpening required ever on blade.

**Removable stoppers to make angle cuts,  
cuts in length and wider than 400 mm  
planks.**

Max. width with stoppers (overall) : 230 mm,  
320 mm and 400 mm.

Cutting capacity : max. 15 mm thickness.

**Accessories :**

- 1 trestle.

- 1 dust collector.





Ref. : 283055 **NEW**

## GRADUATED MULTIFUNCTION BUCKET 33 l

Versatile = allows mixing, transporting, storing, distributing...

Integrated graduations (from 5 to 24 l) for dosing glue preparations, jointing, compound, mortars. Convenient to use thanks to its metal handle and its 2 side handles.

Easy to clean.

Transparent lid sold separately (ref. 528300).

### SPECIFICATIONS

Material	PP
Upper outer diameter	380 mm
Upper inner diameter	357 mm
Lower outer diameter	322 mm
Height	370 mm
Volume to the top edge	33 l

Ref. : 528300

## TRANSPARENT LID

For 33 l graduated  
multifunction bucket



## FLAT SHIM

Dimensions : 100 x 24 mm

To level tiles floors, parquet, laminate flooring, panellings, wooden decks, stone decks, masonry works...

Fast and efficient level set up.

Made of polyethylene.

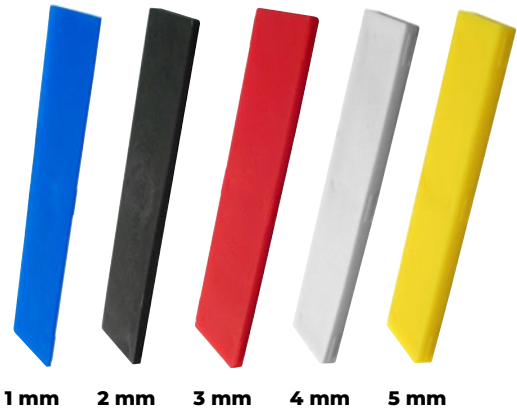

BY COLOR	BLUE	BLACK	RED	WHITE	YELLOW	ASSORTMENT
In carton box / 1000 pcs (Ref.)	186155	186255	186355	186455	186555	186055 200 shims of each thickness
In storage box / 400 pcs (Ref.)	--	--	--	--	--	188955 80 shims of each thickness
In bag / 50 pcs (Ref.)	--	--	--	--	--	188155 10 shims of each thickness



Ref. : 087055 **SET TAK-TIK**

## COMPLETE SET FOR INSTALLING LAMINATE FLOORING



Ideal to install laminate and MDF floorings (click-together design).

### THE SET INCLUDES

<b>Pulling bar (metal frame)</b> : allows easy clicking of the last board along the wall for perfect interlocking.	1
<b>Plastic tapping block</b> : evenly distributes force from hammer when tapping boards together	1
<b>Spacer blocks</b> : to make an expansion joint between the wall and the laminate flooring	50



Ref. : 087355  
**SPACER BLOCK**  
**x 48 pcs**  
 For laminate flooring installation.

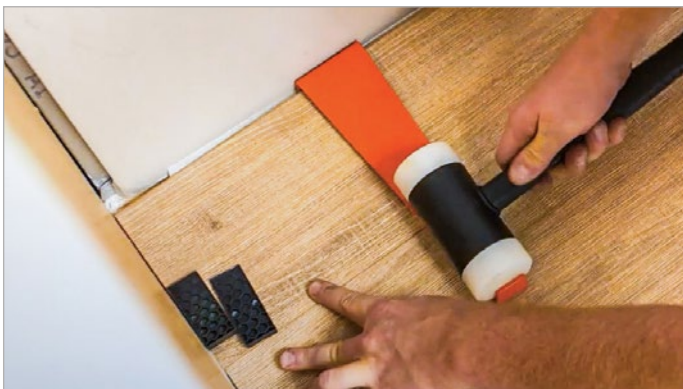



Ref. : 087255

**SUPER TAK-TIK**

## **PULLING BAR FOR LAMINATE FLOORING INSTALLATION**

With crowbar system.

Wide head for larger pulling surface.

Soft-touch material covers the base of the pulling bar to protect the laminate flooring.

For click-together laminate flooring.



Ref. : 262855

**REPLACEABLE TIP**

Ref. : 269155

**BLOC PARKET**

## **TAPPING BLOCK FOR HARDWOOD AND LAMINATE FLOORING**

Dimensions : 500 x 70 x 20 mm.

P.E block.





**NEW**

## PREMIUM MULTIPURPOSE MALLET

Multi-angle head with chamfered edges for easy positioning of flooring without damaging it.

Avoids traces.

Ergonomic, anti-slip handle.

### PREMIUM MALLET

**250 G**

**500 G**

Ref.

261855

261955



FLOORING  
INSTALLER



## MARKLESS MALLET

1 spherical face and 1 flat face.

To position the tile and facilitate its adhesion.

Avoids traces.

### MARKLESS MALLET

**250 G**

**500 G**

Ref.

254055

254155



Ref. : 085055 **CAMELEON 130**

## MITRE GUILLOTINE

130 mm stainless steel blade.

Clean cut without any dust : wooden skirting boards, mouldings, door frames, quarter rounds, flat trims, etc...

Perfect cut up to 28 mm height and 130 mm length with a range of angles from 45 to 90°.

Long handle for a fast and easy cut.

Ideal for cutting european woods (oak, beech...), american woods (cherry, southern yellow pine...), northern pine, PVC panelling, MDF panelling...



Ref. : 071055 **MULTI-COUP® EXTRA**

## MITRE SHEARS WITH VARIABLE ANGLE CUTS

Clean and effortless cut.

Allows easy cutting of decorative moulding, wood skirting boards, rubber seals, PVC sections.



Ref. : 071155  
**STAINLESS STEEL BLADE - 65 MM**  
Re-sharpenable single-block blade.



Ref. : 066055 **FOOTPLAC**

## BOARD LEVER WITH STEEL STIRRUP

### Ideal to un hinge doors.

To lift panels for an accurate positioning thanks to its rocker system.

Wide base for better balance.

Extra wide loop suitable for most safety footwear.



FLOORING  
INSTALLER

Ref. : 260655

## HAND AND SURFACE CLEANING WIPE

x 90 pcs

### No rinsing, drying or residue.

Safe for the epidermis, the wipe has a strong cleaning and detergent power.

Effective on hands as well as on smooth, non-porous surfaces such as worktops, tools, machines, computers, copiers/fax, whiteboards, car interiors, wheel rims. Removes ordinary dirt as well as hard greases, fresh paints, adhesives, oils, lubricants, sludge, inks, waxes, bitumen, tar and other stubborn stains such as coal, graphite and grass marks.

**Composition :** vegetable solvents combined with an abrasive towel, which does not scratch. Classified in cosmetic products.

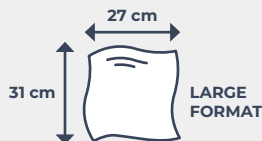

Program listed  
A1-AB-E4  
(Registration  
#147279).



# FACADE INSTALLER RANGE

## EASY CUTTING, WORKSITE QUALITY

EDMA's range of specific tools for façade installer is designed to give users a real time and effort saving on daily work.

Find out the entire range of must-have specific tools for fitting thermal insulation from the outside.

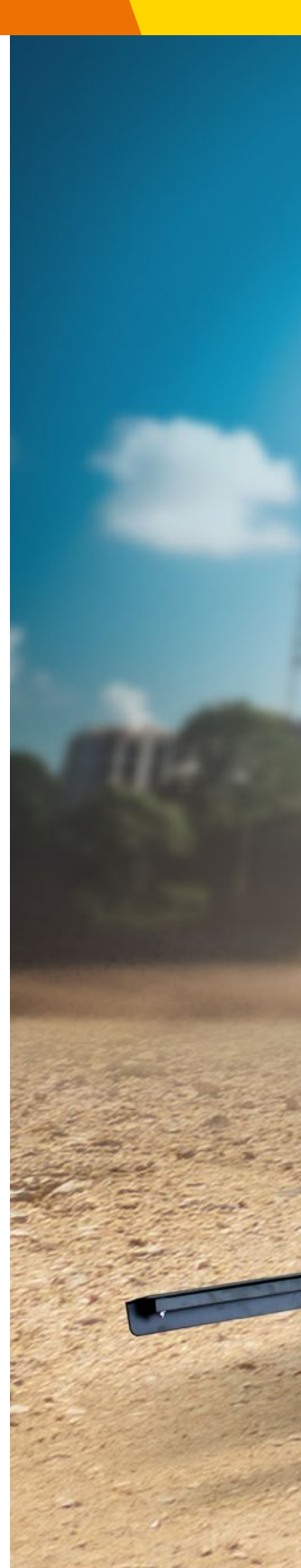



FACADE  
INSTALLER

# CHOOSE YOUR CUTTING MACHINE

SPECIFICATIONS							
	WOOLCUT	OSCILOCUT	OSCILOCUT XL	INSULACUT	EDMAFOAM	DOUBLE HOT WIRE CUTTING TABLE	FOLDABLE HOT WIRE CUTTING TABLE
Ref.	368755	368301 / 368355	368555	366255	366755 / 367555	368155	367155

### Compatible materials

Wood fiber/wool	✓						
Hemp wool	✓						
Recycled cotton wool	✓						
Rock wool	✓	✓	✓	✓			
Glass wool	✓	✓	✓	✓			
Expanded polystyrene	✓	✓	✓		✓	✓	✓
Extruded polystyrene	✓	✓	✓		✓	✓	✓
Polyurethane	✓	✓	✓				
Phenolic foam		✓	✓				
Glass foam		✓	✓				
Rubber foam		✓	✓				

<b>Cutting type</b>	Blade	Vibrating wire	Vibrating wire	Blade	Blade	Hot wire	Hot wire
<b>Power supply</b>	Lithium battery	Lithium battery	Lithium battery	Lithium battery	230 V mains supply	230 V mains supply or optional lithium battery	230 V mains supply or optional lithium battery pack
<b>Max. cutting height</b>		650 mm	1460 mm			1320 mm	Adjustable from 810 to 1400 mm
<b>Max. cutting thickness/depth</b>	240 mm	270 mm	340 mm	300 mm	200 mm / 250 mm	330 mm	320 mm
<b>Carrying case</b>	✓	According to reference	✓	✓	✓	✓	✓





**EDMA electric saw  
WOOLCUT**  
Ref. 368755

(sold separately)

**Sliding cutting  
carriage**

**CAN BE FITTED  
WITH VARIOUS  
ELECTRIC  
INSULATION SAWS**

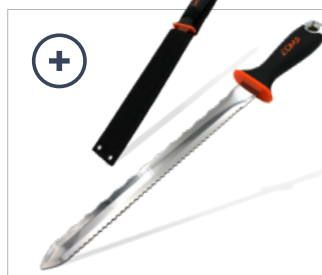
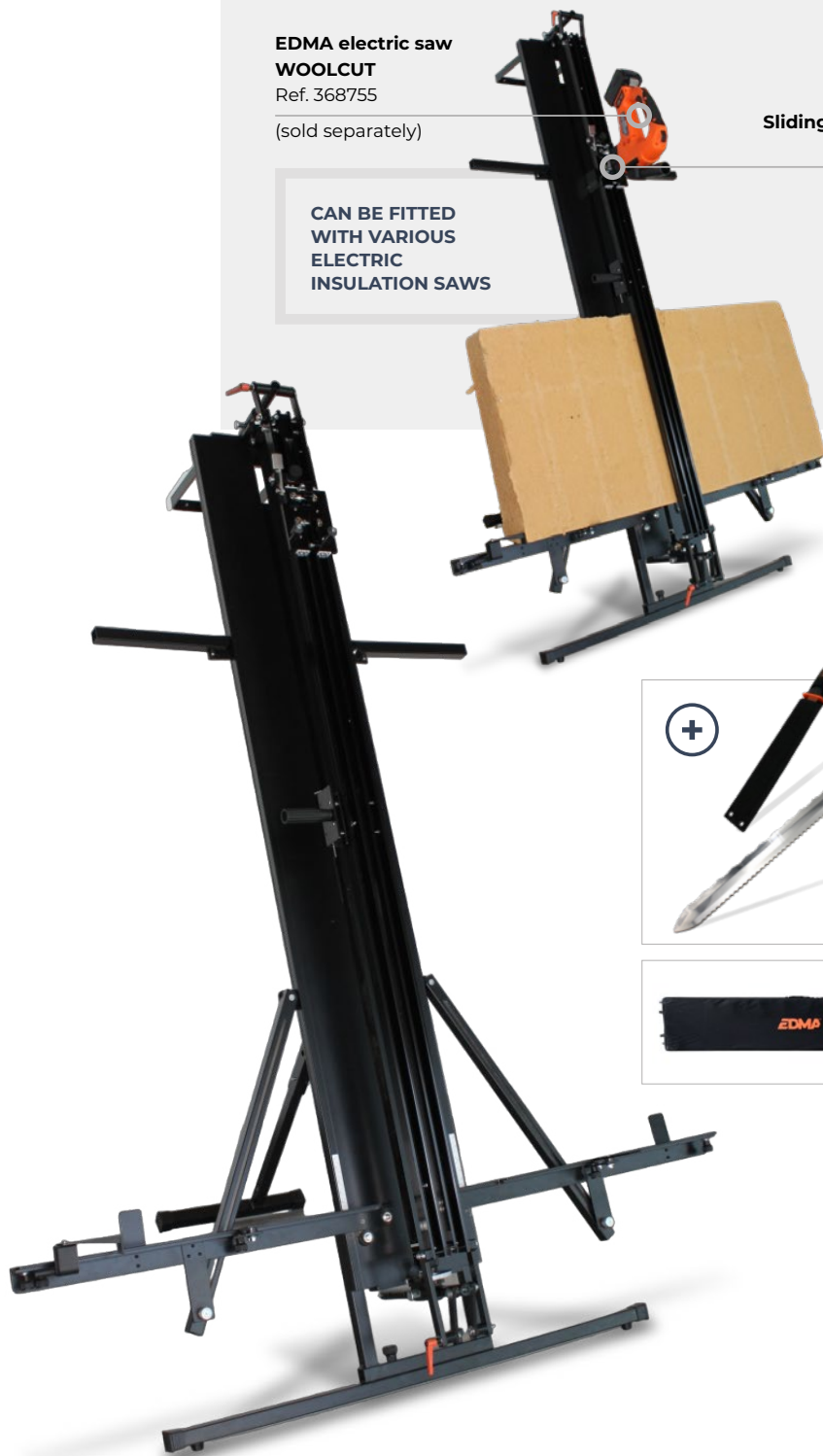



Ref. : 368655 **NEW**

## CUTTING TABLE

### For bio-based insulation materials

Stable, strong aluminum cutting jig.

Combined with the WOOLCUT electric saw ref. 368755 (sold separately), it allows to cut natural-fiber insulation (density < 90 kg/m<sup>3</sup>) such as wood fiber/wool, hemp and recycled cotton, but also rock wool, glass wool, polyurethane, polystyrene...

Can be fitted with various electric insulation saws.

Equipped with 2 adjustable-angle side guide rulers.

Cutting carriage slides on a depth-adjustable swivel guide.

### SPECIFICATIONS

Max. cutting height (with electric saw)	1350 mm
Max. cutting thickness (with electric saw)	300 mm

### Delivered with :

- 300 mm EDMA insulation knife ref. 066455.
- Drilling template for BOSCH saw GFZ 16-35 AC mounting.
- Drilling template for DEWALT DWE 397 and DSC 397 saw mounting.
- Drilling template for FESTOOL saw ISC 240 mounting.
- Angled socket wrench.
- Allen key.
- Carrying case with wheels.

### Possible cutting shapes :

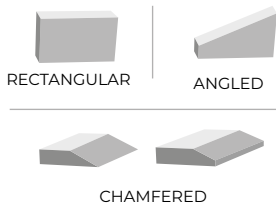

Ref. : 536865  
**ADAPTOR FOR WOOLCUT, BOSCH GFZ 16-35 AC, FESTOOL ISC 240, DEWALT DWE 397/DSC 397 SAWS**



Ref. : 536860  
**DRILLING TEMPLATE FOR BOSCH SAW GFZ 16-35 AC**



Ref. : 536861  
**DRILLING TEMPLATE FOR FESTOOL SAW ISC 240**



Ref. : 536862  
**DRILLING TEMPLATE FOR DEWALT SAWS DWE 397/DSC 397**



Ref. : 536864  
**ADAPTOR FOR INSULACUT SAW**



**Cutting guide** with adjustable angle

**Cutting guide** on wheels

Ref. : 368755

**WOOLCUT** **NEW**

## CORDLESS ELECTRIC SAW

**For bio-based and mineral insulation materials**

**Ideal for cutting natural-fiber insulation** (density < 90 kg/m<sup>3</sup>) such as wood fiber/wool, hemp and recycled cotton, but also rock wool, glass wool, polyurethane, polystyrene...

Battery operated for greater freedom of work.

Equipped with an opposed-movement double blade for fast, efficient cutting, while reducing vibration.

2 types of double blade : for flexible and compressed insulation.

Brushless motor = powerful, durable, low-maintenance.

Ergonomic design with 2 ON/OFF buttons for ease of use.

Double-click protection system prevents accidental start-up = safety.

CE certified.

### SPECIFICATIONS

Cutting angle	90° - 45°
Max. cutting thickness	240 mm
Voltage	18 V DC
Battery	18 V - 4 Ah Li-ion
Battery charger	21 V - 2,3 A
Stroke	30 mm
No-load stroke rate	2800 spm (strokes/min)

### Delivered with :

- 2 batteries 18 V - 4 Ah + charger.
- 1 double blade 240 mm for flexible insulation.
- 1 double blade 240 mm for compressed insulation.
- 2 cutting guides : top with adjustable angle and bottom on wheels.
- Vacuum hood + adapter for vacuum cleaner.
- Carrying case.



Ref. : 536888  
**240 MM BLADE HOLDER**



Ref. : 536893  
**240 MM DOUBLE BLADE FOR FLEXIBLE INSULATION**



Ref. : 536895  
**240 MM DOUBLE BLADE FOR COMPRESSED INSULATION**



Ref. : 536889  
**350 MM BLADE HOLDER**



Ref. : 536894  
**350 MM DOUBLE BLADE FOR FLEXIBLE INSULATION**



Ref. : 536896  
**350 MM DOUBLE BLADE FOR COMPRESSED INSULATION**



Ref. : 536881  
**SPARE BATTERY**  
Lithium battery 18 V - 4 Ah.



Ref. : 536832  
**BATTERY CHARGER**  
For lithium battery 18 V.



Ref. : 536843  
**DUAL BATTERY CHARGER**  
For lithium battery 18 V.



Ref. : 536887  
**CUTTING GUIDE WITH ADJUSTABLE ANGLE**



Ref. : 536892  
**CUTTING GUIDE WITH WHEELS**



Ref. : 536897  
**VACUUM HOOD**



Ref. : 536898  
**ADAPTOR FOR VACUUM CLEANER**





## OSCILOCUT

# VIBRATING WIRE CUTTING TABLE

### For insulation materials

Clean cut of insulation materials such as mineral wool : rock wool, glass wool, but also polyurethane, expanded and extruded polystyrene (E.P.S. and X.P.S.), phenolic foam, glass foam, rubber foam.

Battery operated for greater freedom of work.

Delivered assembled, compact for easy storage and transport.

CE certified.

**NEW**

	OSCILOCUT	OSCILOCUT XL
In aluminium and wood carrying case with wheels (Ref.)	368355	368555
Without carrying case (Ref.)	368301	---
Max. cutting height	650 mm	1460 mm
Max. cutting thickness	270 mm	340 mm
Motor	18 V brushless = longer life	18 V brushless = longer life
Lithium battery	18 V - 2 Ah	18 V - 2 Ah
Vibration frequency	1500 times/min	1500 times/min

### Accessories included :

- Battery + battery charger
- 6 cutting wires
- 3 spare self-adhesive rough tapes
- 5 spare brake caps

### Possible cutting shapes :

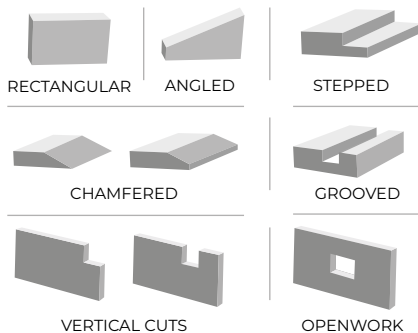

Ref. : 536830  
**SPARE CUTTING WIRE FOR OSCILOCUT**



Ref. : 536850  
**SPARE CUTTING WIRE FOR OSCILOCUT XL**



Ref. : 536831  
**SPARE BATTERY**  
Lithium battery 18 V - 2 Ah.



Ref. : 536832  
**BATTERY CHARGER**  
For lithium battery 18 V.



Ref. : 536843  
**DUAL BATTERY CHARGER**  
For lithium battery 18 V.



Ref. : 536840  
**PACK 2 BATTERIES 18 V - 2 AH + DUAL CHARGER**

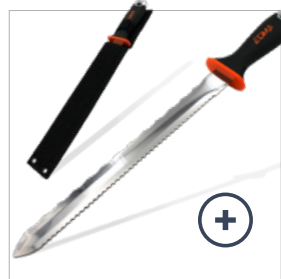

Ref. : 366955

## MINERAL WOOL CUTTING TABLE

Special for rock wool panels.  
Ideal to cut sheep wool, glass wool, cellulose wadding...  
Allows accurate and clean cuts.  
Made of aluminium.

### SPECIFICATIONS

Max. cutting height	1200 mm
Max. cutting thickness	260 mm
Chamfered cut	up to 45°
Angle cut	up to 50°

### Accessories included :

- 300 mm EDMA insulation knife ref. 066455.
- Carrying case with wheels

### Possible cutting shapes :

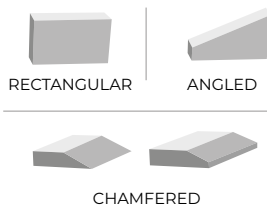



CE

Blade length :  
300 mm



Ref. : 366255 **INSULACUT**

## RECIPROCATING ELECTRIC SAW FOR MINERAL INSULATION MATERIAL

*Effortless, accurate and clean cut.*

Special for mineral insulation material such as rock wool.

14.4 V - 1.5 Ah Li-ion battery and charger included.

Blade length : 300 mm.

CE certified.



Ref. : 366355  
**SPARE BLADE - 300 MM**



Ref. : 536621  
**SPARE BATTERY**  
Lithium battery 14,4 V - 1,5 Ah.



Ref. : 536622  
**BATTERY CHARGER**  
For lithium battery 14,4 V - 1,5 Ah.



## INSULATION CUTTER

Easy to use for all types of insulation materials.

2 different tooth shapes.

Holster included.

Symmetrical bi-material handle.

To cut without any effort rock wool, glass wool, wood wool or hemp insulating panels, flax, cellulose wadding panels, etc... from 3 to 20 cm thick.

DIMENSIONS	300 MM	420 MM
Ref.	066455	168055





**EDMAFOAM**

**HOT KNIFE WITH AIR-COOLING SYSTEM**

*Faster*, clean and effortless cutting of polystyrene panels

(E.P.S./X.P.S.).

No dust.

Air-cooling system enabling to be continuously operated.

Power: 320 W.

CE certified.



EDMAFOAM	STARTING KIT	HOT KNIFE + 3 BLADES SET
Ref.	366755	367555

**DELIVERED WITH :**

Plastic case	✓	✓
200 mm blade	✓	✓
250 mm blade		✓
30 mm groove cutter		✓
Metallic brush	✓	✓
Blade fixing key	✓	✓

## ACCESSORIES FOR HOT KNIFE



**NEW**

Ref. : 536671

**EXTENSION**

**120 CM**

**Ideal for floor grooving.**

Fits on the **EDMAFOAM** hot knife ref. 366755/367555.

Makes it easier to cut expanded and extruded polystyrene panels (E.P.S. and X.P.S.), at height or on the ground, avoiding bending down.

**Compatible with :**

- Blades 15, 20 and 25 cm ref. 266755, 466755 and 536750.
- Groove cutter  $\varnothing$  30 mm ref. 466555.
- Adjustable blind hole cutter  $\varnothing$  30 to 150 mm ref. 466955.
- Blind hole cutter  $\varnothing$  70 mm ref. 466455.



Ref. : 466955

**NEW**

**ADJUSTABLE BLIND HOLE CUTTER**

**$\varnothing$  30 - 150 MM**

**Kit for hot knife**



**Ideal for inserting electrical boxes and drain pipes.**

**Consists of :**

- 1 perforator frame with a pre-assembled  $\varnothing$  100 mm formed cutting wire.
- 2 spare cutting wires to be formed according to the desired perforation diameter.
- 1 pliers to form the cutting wires.

Ref. : 546690

**SPARE CUTTING WIRE**



Ref. : 466455

**BLIND HOLE CUTTER**

**$\varnothing$  70 mm**

Max. depth : 70 mm.

Min. depth : 25 mm.

Ideal for electrical box.



Ref. : 466555

**GROOVE CUTTER**

**$\varnothing$  30 mm**

Perfect 30 mm groove cut.

Ideal for electrical pipes.



Ref. : 466655

**CUTTING GUIDE**

**210 mm**

Perfect straight cut up to 210 mm width.



**SPARE BLADE**

Ref. : 266755

**15 cm**

Ref. : 466755

**20 cm**

Ref. : 536750

**25 cm**

MAINS OR  
BATTERY  
OPERATED

ALREADY  
ASSEMBLED



CE



Ref. : 368155 **NEW**

## DOUBLE HOT WIRE CUTTING TABLE

For polystyrene, especially for E.T.I.C.S. applications

**Clean cut without polystyrene beads projection.**

For expanded and extruded polystyrene (E.P.S. and X.P.S.).

System with 2 perpendicular hot wires that move in the same frame thanks to 2 sliders.

Mains operated, with integrated 2-battery support for cordless use (18 V - 2 Ah battery sold separately ref. 536831 or in a pack of 2 batteries + double charger ref. 536840).

Delivered assembled, foldable for easy storage and transport.

CE certified.

### SPECIFICATIONS

Max. cutting height	1320 mm
Max. cutting depth	330 mm
Adjustable frame	from 0 to 45°

### Accessories included :

- Carrying case with wheels.
- 3 cutting wires of each length.

### Possible cutting shapes :

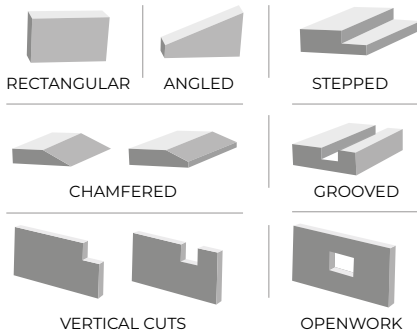

Ref. : 536823  
**1430 MM SPARE CUTTING WIRE**



Ref. : 536824  
**370 MM SPARE CUTTING WIRE**



Ref. : 536825  
**TRANSFORMER**



Ref. : 536840  
**PACK 2 BATTERIES 18 V - 2 AH + DUAL CHARGER**



Ref. : 536826  
**DUAL HOLDER FOR LITHIUM BATTERY 18 V**



Ref. : 536831  
**SPARE BATTERY**  
Lithium battery 18 V - 2 Ah.



Ref. : 536832  
**BATTERY CHARGER**  
For lithium battery 18 V.



Ref. : 536843  
**DUAL BATTERY CHARGER**  
For lithium battery 18 V.



ADJUSTABLE  
HEIGHT

ALREADY  
ASSEMBLED

CE





Ref. : 367155

## FOLDABLE HOT WIRE CUTTING TABLE

For polystyrene, especially for E.T.I.C.S. applications

*Clean* cut without polystyrene beads projection.

For expanded and extruded polystyrene (E.P.S. and X.P.S.).

Already assembled.

Transformer : 42 V / 240 W / 230 V.

CE certified.

### SPECIFICATIONS

Adjustable cutting height	from 810 to 1400 mm
Max. cutting depth	320 mm

### Accessories included :

- Carrying case
- Holder
- 2 wire rolls

#### Possible cutting shapes :

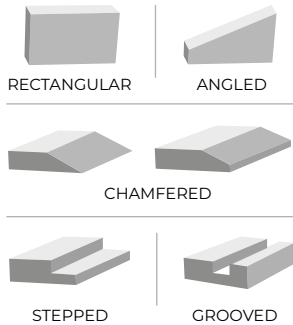

Ref. : 536712  
**HOLDER**



Ref. : 367455  
**2 M SPARE CUTTING WIRE ROLL**



Ref. : 536711  
**TRANSFORMER**



Ref. : 526666  
**PACK LITHIUM BATTERY**  
Composed of a 36 V - 2 Ah lithium battery and its charger + a battery rack to connect to the machine.



Ref. : 526665  
**SPARE BATTERY**  
Lithium battery 36 V - 2 Ah.



Ref. : 526793  
**BATTERY CHARGER**  
For lithium battery 36 V - 2 Ah.



Ref. : 526667  
**FOOT SWITCH**  
Cutting action controlled by foot.  
Allows to get free hands to make step cuts or channels easily on E.P.S. panels.  
Secured by a steel shell.



Ref. : 266555

## HOT WIRE CUTTING TABLE

**For polystyrene, especially for E.T.I.C.S. applications**

*Clean* cut without polystyrene beads projection.

For expanded and extruded polystyrene (E.P.S. and X.P.S.).

Transformer : 40 V / 200 W / 230 V.

CE certified.

### SPECIFICATIONS

Max. cutting depth	330 mm
Max. cutting height	1320 mm
Angle cut	from 0 to 90°
Chamfered cut	from 90 to 15°
Groove cutting	until 300 mm depth

### Accessories included :

- Carrying case with wheels
- Holder
- Folding feet
- 2 cutting wires

### Possible cutting shapes :

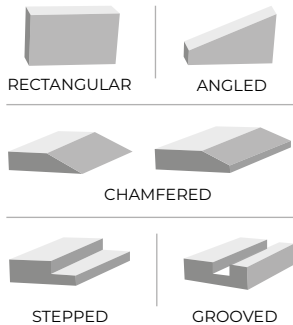

Ref. : 526652  
**HOLDER**



Ref. : 366855  
**1500 MM SPARE CUTTING WIRE**



Ref. : 267155  
**TRANSFORMER**



Ref. : 526666  
**PACK LITHIUM BATTERY**  
Composed of a 36 V - 2 Ah lithium battery and its charger + a battery rack to connect to the machine.



Ref. : 526665  
**SPARE BATTERY**  
Lithium battery 36 V - 2 Ah.



Ref. : 526793  
**BATTERY CHARGER**  
For lithium battery 36 V - 2 Ah.



Ref. : 526667  
**FOOT SWITCH**  
Cutting action controlled by foot. Allows to get free hands to make step cuts or channels easily on E.P.S. panels. Secured by a steel shell.



Ref. : 366655

## HOT WIRE CORNER CUTTER

### For polystyrene

Cutting accessory for expanded polystyrene (E.P.S.) and extruded polystyrene (X.P.S.) to adapt on a hot wire cutting table (ref. 266555/367155).

Allows multiple vertical cutting possibilities.

Operates independently on 18 V - 2 Ah lithium battery.

Possibility of connecting the corner cutter directly to the power supply of the table ref. 367155, using the spring cable ref. 536713. CE certified.

#### ON THE TABLE REF. 266555 :

##### 2 possible positions depending on the height of the panels to be cut :

- High position : for panels up to 1000 mm high.
- Low position : for panels up to 600 mm high.

#### ON THE TABLE REF. 367155 :

##### 3 possible positions depending on the height of the panels to be cut :

- High position : for panels up to 1015 mm high.
- Intermediate position : for panels up to 815 mm high.
- Low position : for panels up to 615 mm high.

#### SPECIFICATIONS

Max. cutting depth	500 mm
Max. cutting thickness	310 mm

#### Accessories included :

- Carrying case.
- Battery + battery charger.
- 2 cutting wires.

#### Possible cutting shapes :

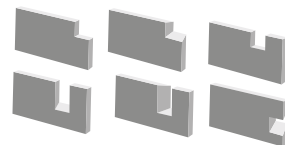

Ref. : 466855  
**610 MM SPARE CUTTING WIRE**



Ref. : 536832  
**BATTERY CHARGER**  
For lithium battery 18 V.



Ref. : 536840  
**PACK 2 BATTERIES 18 V - 2 AH + DUAL CHARGER**



Ref. : 536831  
**SPARE BATTERY**  
Lithium battery 18 V - 2 Ah.



Ref. : 536843  
**DUAL BATTERY CHARGER**  
For lithium battery 18 V.

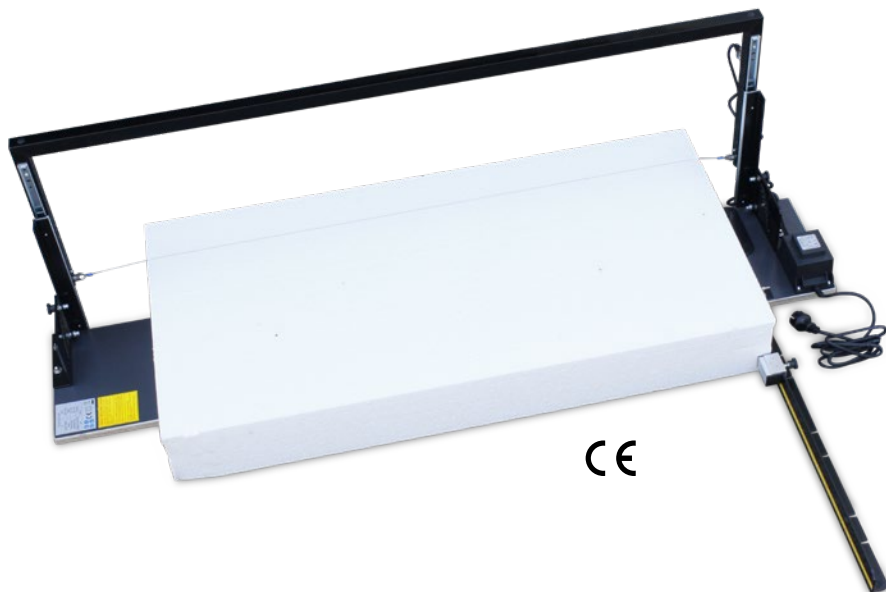

Ref. : 260155

## HORIZONTAL HOT WIRE CUTTING TABLE

For polystyrene

*Clean cut without polystyrene beads projection.*

For expanded and extruded polystyrene (E.P.S. and X.P.S.).

Transformer : 40 V / 200 W / 230 V.

CE certified.

### SPECIFICATIONS

Max. cutting depth	330 mm
Max. cutting width	1 320 mm
Angle cut	from 0 to 90°
Chamfered cut	from 90 to 15°

#### Possible cutting shapes :

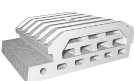
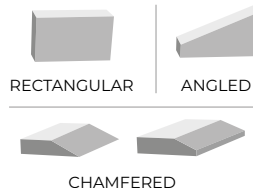

IDEAL FOR CUTTING POLYSTYRENE SLABS



Ref. : 266855  
1370 MM SPARE CUTTING WIRE



Ref. : 267155  
TRANSFORMER



Ref. : 526666  
**PACK LITHIUM BATTERY**  
Composed of a 36 V - 2 Ah lithium battery and its charger + a battery rack to connect to the machine.



Ref. : 526665  
**SPARE BATTERY**  
Lithium battery 36 V - 2 Ah.



Ref. : 526793  
**BATTERY CHARGER**  
For lithium battery 36 V - 2 Ah.



**Battery operated** for greater freedom of work





**STYROGUN** **NEW**

## CORDLESS HOT WIRE CUTTER

For polystyrene

*Clean* cut without polystyrene beads projection.

For expanded and extruded polystyrene (E.P.S. and X.P.S.).

Allows a multitude of precise and fast cuts thanks to its linear translation guide.

Grooving possible thanks to its adjustable depth stop.

Optimized mobility on the worksite : cordless, compact design, light weight.

CE certified.

STYROGUN	WITH BATTERY AND CHARGER	WITHOUT BATTERY OR CHARGER
Ref.	368455	368401
Max. cutting height	630 mm	630 mm
Max. cutting depth	310 mm	310 mm
Adjustable linear guide for angled cuts	from 0 to 45°	from 0 to 45°
Lithium battery	18 V - 2 Ah	18 V - 2 Ah (sold separately)

### ACCESSORIES INCLUDED

Carrying case	1	1
Battery + battery charger	1	--
Cutting wires	3	3

#### Possible cutting shapes :

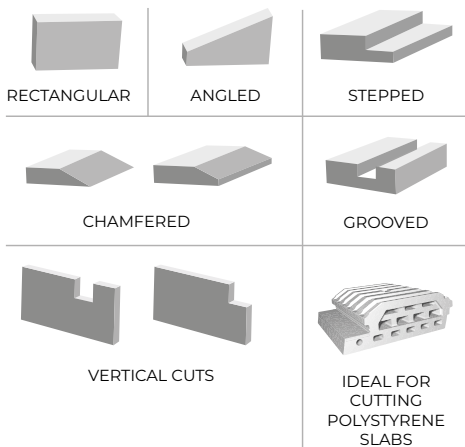

Ref. : 536841  
**678 MM SPARE CUTTING WIRE**



Ref. : 536831  
**SPARE BATTERY**  
Lithium battery 18 V - 2 Ah.



Ref. : 536832  
**BATTERY CHARGER**  
For lithium battery 18 V.



Ref. : 536843  
**DUAL BATTERY CHARGER**  
For lithium battery 18 V.



Ref. : 536840  
**PACK 2 BATTERIES**  
**18 V - 2 AH**  
**+ DUAL CHARGER**



Ref. : 267955

**Battery operated**  
for greater freedom  
of work

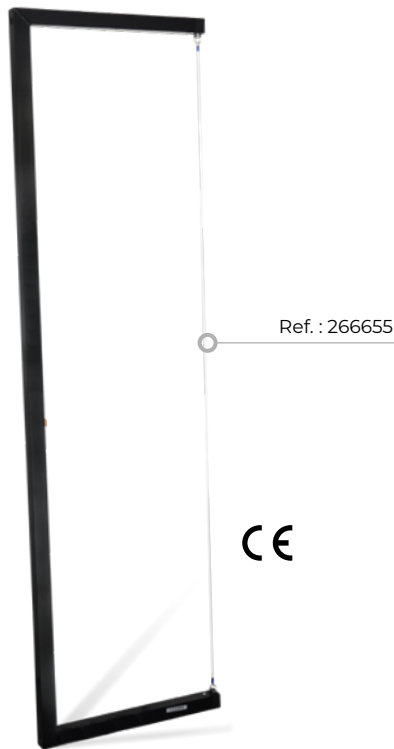

Ref. : 266655

## HOT WIRE CUTTING BOW

For polystyrene

*Clean* cut without polystyrene beads projection.

For expanded and extruded polystyrene (E.P.S. and X.P.S.).  
CE certified.

HOT WIRE CUTTING BOW	BATTERY OPERATED	MAINS OPERATED
Ref.	267955	266655
Max. cutting depth	330 mm	330 mm
Max. cutting width	1 370 mm	1 370 mm
Power supply	Lithium battery 36 V - 2 Ah	Transformer 40 V / 200 W / 230 V

Possible cutting shapes :



RECTANGULAR



ANGLED

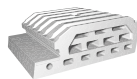

IDEAL FOR  
CUTTING  
POLYSTYRENE  
SLABS



Ref. : 266855  
1370 MM SPARE CUTTING WIRE



Ref. : 267155  
TRANSFORMER



Ref. : 526665  
SPARE BATTERY  
Lithium battery 36 V - 2 Ah.



Ref. : 526793  
BATTERY CHARGER  
For lithium battery 36 V - 2 Ah.



Ref. : 069055 **CANALCUT**

## PRECISION INSULATION CUTTER

**For all types of insulation materials, such as : E.P.S., polyurethane, rock wool, glass wool, underfloor heating.**

Groove stainless steel blade for making 35 mm (width) x 35 mm (depth) channel to insert pipes up to 32 mm diameter max.

### 2 INTERCHANGEABLE BLADES :

#### 1/ 35 x 35 mm groove blade :

Thermal bridges are easily avoided while cutting.

#### 2/ 80 mm blade for curved shape removal :

Scoring E.P.S. plasterboard.

Roofing water insulation grading.

To cut insulation material.



Ref. : 069555  
**GROOVE BLADE**  
**35 X 35 MM**



Ref. : 068155  
**BLADE SET**  
**40, 60, 80, 100 MM**



Ref. : 164955

## ABRASIVE SANDER SPECIAL FOR E.T.I.C.S.

**380 x 160 mm**

Ideal for sanding polystyrene panels and cellular concrete.



Ref. : 283055 **NEW**

## GRADUATED MULTIFUNCTION BUCKET 33 l

Versatile = allows mixing, transporting, storing, distributing...

Integrated graduations (from 5 to 24 l) for dosing glue preparations, jointing, compound, mortars.

Convenient to use thanks to its metal handle and its 2 side handles.

Easy to clean.

Transparent lid sold separately (ref. 528300).

### SPECIFICATIONS

Material	PP
Upper outer diameter	380 mm
Upper inner diameter	357 mm
Lower outer diameter	322 mm
Height	370 mm
Volume to the top edge	33 l

Ref. : 528300

## TRANSPARENT LID

For 33 l graduated  
multifunction bucket



Ref. : 065455

## INSIDE CORNER TROWEL

Stainless steel blade.

To spread compound on both interior sides of the wall in one single pass.

Ergonomic handle.

Angle 103°.



Ref. : 065755

## OUTSIDE CORNER TROWEL

Stainless steel blade.

To spread compound on both exterior sides of the wall in one single pass.

Ergonomic handle.

Angle 87°.





### Flexible blade

Blade thickness : 0,3 mm.

### Stiff blade

Blade thickness : 0,5 mm.

Adaptable to EDMA telescopic poles (handle and poles not included, see page 98).

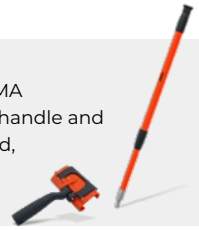

## EDMABLADE

### SMOOTHING BLADE

Allows smoothing of compounds, drywall tapes, plaster.

Easy to use thanks to its light and ergonomic structure.

Stainless steel blade with rounded edges for a result without trace or loss of compound.

EDMABLADE	60 CM	80 CM	100 CM
Flexible blade (Ref.)	172055	172155	172255
Stiff blade (Ref.)	372055	372155	372255

Ref. : 260655

### HAND AND SURFACE CLEANING WIPE

x 90 pcs

**No rinsing, drying or residue.**

Safe for the epidermis, the wipe has a strong cleaning and detergent power.

Effective on hands as well as on smooth, non-porous surfaces such as worktops, tools, machines, computers, copiers/fax, whiteboards, car interiors, wheel rims.

Removes ordinary dirt as well as hard greases, fresh paints, adhesives, oils, lubricants, sludge, inks, waxes, bitumen, tar and other stubborn stains such as coal, graphite and grass marks.

**Composition :** vegetable solvents combined with an abrasive towel, which does not scratch. Classified in cosmetic products.

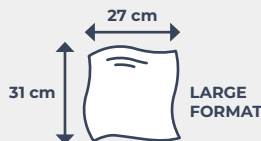

Program listed A1-AB-E4 (Registration #147279).



# ROOFER RANGE

## AGILE SHAPING, FASTENING DURABILITY

EDMA's range of specific tools for roofer is designed to give users a real time and effort saving on daily work.

Find out the entire range of must-have specific tools to build and renovate slate and zinc roofs.









Ref. : 130555

## LEATHER NAIL POUCH

Made of smooth top-grain cowhide leather.  
Adjustable leather/nylon belt.

### SPECIFICATIONS

Large pocket	2
Tool holder	1

Ref. : 260055

## LEATHER TOOL POUCH

Made of smooth top-grain cowhide leather.  
Clip-on, adjustable belt included.

### SPECIFICATIONS

Storage compartment	8
Tool holder	2
Tape measure holder	1





Ref. : 280155

## NYLON CONTRACTOR RIG

Reinforced adjustable belt with roller buckle.

### SPECIFICATIONS

Storage compartment	8
Tool holder	2
Tape measure holder	1

Ref. : 280055

## NYLON CONTRACTOR RIG XL

Reinforced adjustable belt with roller buckle.

### SPECIFICATIONS

Storage compartment	12
Steel hammer holder	2
Tape measure holder	1



Ref. : 283055 **NEW**

## GRADUATED MULTIFUNCTION BUCKET 33 l

Versatile = allows mixing, transporting, storing, distributing...

Integrated graduations (from 5 to 24 l) for dosing glue preparations, jointing, compound, mortars.

Convenient to use thanks to its metal handle and its 2 side handles.

Easy to clean.

Transparent lid sold separately (ref. 528300).

### SPECIFICATIONS

Material	PP
Upper outer diameter	380 mm
Upper inner diameter	357 mm
Lower outer diameter	322 mm
Height	370 mm
Volume to the top edge	33 l



Ref. : 528300

## TRANSPARENT LID

For 33 l graduated  
multifunction bucket

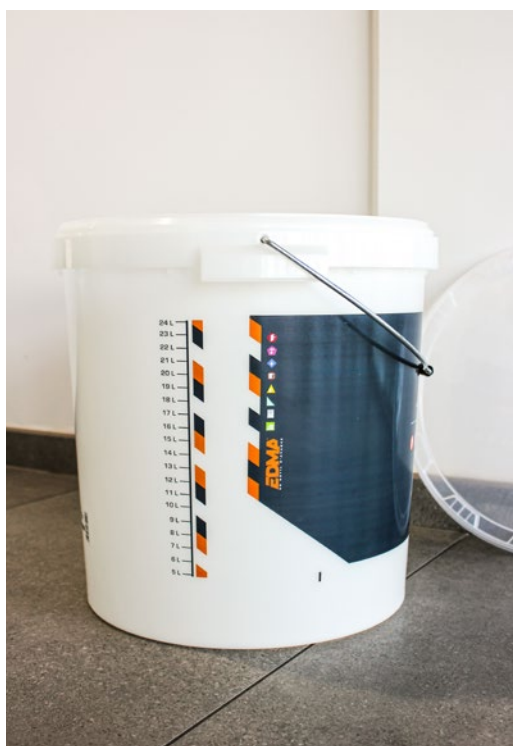



Ref. : 033255 **LIT' UP**

## WOODEN BATTEN REMOVER

For roof renovation.  
Heavy-duty.

### SPECIFICATIONS

Resistance to effort	1 ton
Center distance	150 mm



Ref. : 087555 **DÉCHAUSS' TOUT**

## TELESCOPIC WOODEN BATTEN REMOVER

Telescopic arm  
Heavy-duty.

### SPECIFICATIONS

Telescopic arm	min. 550 mm max. 940 mm
Resistance to effort	1 ton
Center distance	150 mm

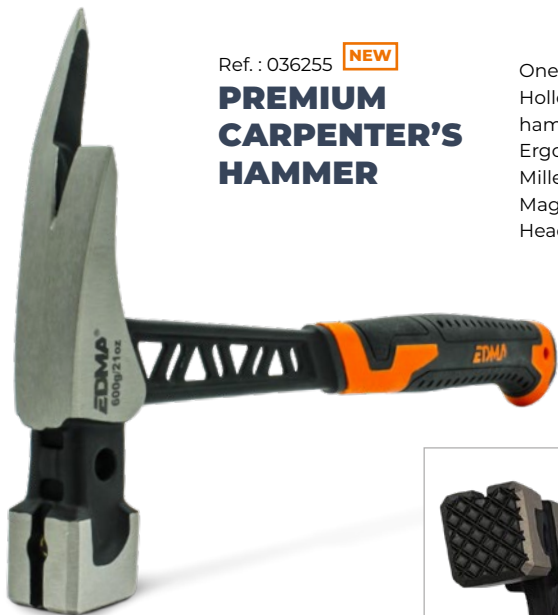

Ref. : 036255 **NEW**

## PREMIUM CARPENTER'S HAMMER

One-piece forged.  
Hollowed-out handle allowing to reduce  
hammering vibration/shock.  
Ergonomic, anti-slip grip.  
Milled face.  
Magnetic nail holder.  
Head weight : 600 g.



Ref. : 035855

## ROOFER'S HAMMER

Steel tube handle.  
PVC grip.  
Magnetic nail holder.  
Polished finish.



Ref. : 035955

## FORGED ROOFER'S HAMMER

All steel forged.  
Leather handle.  
Magnetic nail holder.





Ref. : 036755

## LATHE AXE

Polished blade.  
With nail puller.

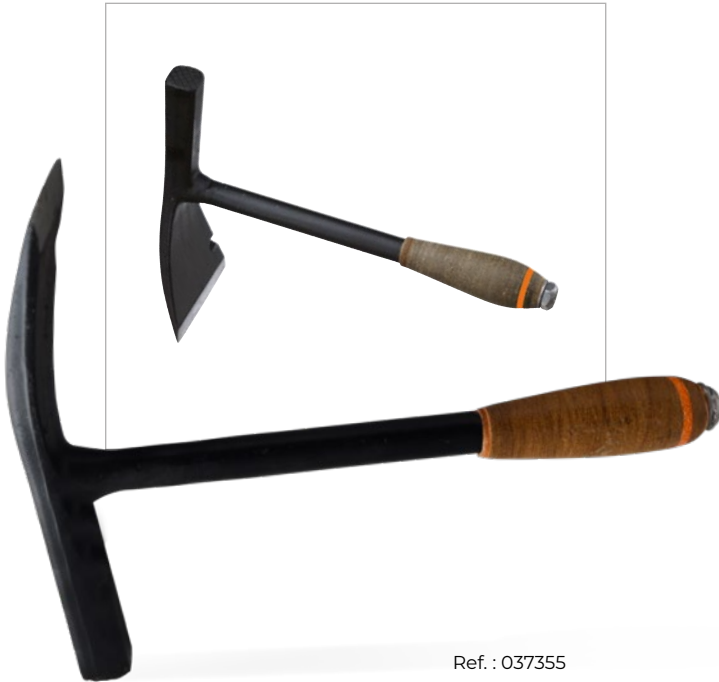

Ref. : 037355

## ROOFER'S ADZE

Hand forged.  
With nail puller and hammer face.  
Leather handle.



Ref. : 060955 **MAX LINE**

## CHALK LINE REEL WITH LARGE HANDLE

**50 m**

For long distance marking.  
Built-in filter system to prevent excess  
chalk.  
Rope diameter: 2,5 mm (braided).  
Capacity: 300 g.



Ref. : 260555  
Ø 2.5 MM BRAIDED  
SPARE ROPE



Ref. : 064255 **ROOF LINE**

## CHALK LINE REEL SPECIAL FOR ROOFERS

**30 m**

Chalk line reel with two handles.  
To reduce movement on the roof.  
Rope diameter : 1,5 mm (braided).  
Capacity : 2 x 100 g.  
Built-in filter system to prevent excess  
chalk.



Ref. : 564255  
Ø 1.5 MM BRAIDED  
SPARE ROPE



## MARKING CHALK

WEIGHT	200 G	400 G	1 000 G	3 500 G
<b>BLUE</b> (Ref.)	063355	063255	063155	065255
<b>RED</b> (Ref.)	063855	064955	064355	065155

Ref. : 283155 **EDMARKER** **NEW**

## CONSTRUCTION PENCIL WITH RETRACTABLE LEAD

Allows marking on a wide range of surfaces and materials, such as : concrete, tiles, metal, wood, parquet...  
ABS and stainless steel for strength and durability.

Push-button with integrated sharpener.

Ergonomic design facilitates marking in tight areas or through holes.

Practical storage holster with belt clip.

Easy-to-clean markings.

Supplied with one lead  $\varnothing$  2.8 x 120 mm, in grey 2B graphite.

Can be fitted with colored leads (sold separately).



Ref. : 283255  
**GREY LEAD**  
**x 6 pcs**  
Made of 2B graphite.



Ref. : 283355  
**COLOR LEAD**  
**x 6 pcs**  
1 grey 2B graphite lead.  
5 wax leads : white, orange, yellow,  
blue and red.

Dimensions :  $\varnothing$  2.8 x 120 mm.  
Suitable for marking on a wide range of  
surfaces and materials, such as : concrete,  
tiles, metal, wood, parquet...



Ref. : 132955  
**CARPENTER PENCIL**  
**x 12 pcs**

To mark on dry wood.



Ref. : 031855 **PUNCHER**  
**HAMMER TACKER**

Recommended for fixing rain barrier, vapour barrier, under-roof radiant barrier films, sealing strips for timber-frame houses and protective strips for wooden joists.

Solidary magazine with quick and easy staple loading.

Magazine capacity : approx. 175 staples.

Large striking range.

Very good balance.

Ultra-comfortable bi-material handle.



**STAPLE**

Galvanised staples.

Width: 10.6 mm.

Thickness: 1.2 mm.

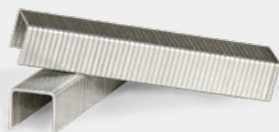

HEIGHT	8 MM	10 MM	12 MM	14 MM
1000 pcs (Ref.)	232055	232155	232255	231955
5000 pcs (Ref.)	---	031955	---	---



Ref. : 133355

## DECLIMETER

Allows to determine the inclination of the roof structure.  
Graduations every degree.



Ref. : 032855

## BATTEN GAUGE

**For wooden batten positioning**

Easy to use.  
Aluminium pattern.  
With scale from 15 to 40 mm.



Ref. : 035555 **ROLL MAT**

## **SLATE CUTTER**

**600 mm**



Registered design.

For natural and synthetic slates.

Max. cutting thickness : 6 mm.

2 different working positions : straight position for ground work and tilted position for roof work.

Can be easily attached to roof battens thanks to its notches.

Large cutting platform graduated every 10 mm.

Square gauges for regular straight and angular cuts.

Cutting trolley guiding on bearings and rubber end stops.

Trolley locking system.

Carrying strap and dust collector included.



Ref. : 503550  
**SPARE CUTTING DISC**





Ref. : 033055 **PRO MAT-COUP 210**

## **SLATE CUTTER**

Clean and effortless cut up to 7 mm thickness.

Easy forward movement of the slate for progressive cutting action.

Easy to move on the roof, with a fixing point for laths.



Ref. : 231055 **MASTERCUT**

## SLATE CUTTING AND PUNCHING PLIERS

**2 in 1 = slate cutting and punching.**

Optimised lever system for effortless cutting.

Innovative design for two different working ways (classic and reverse).

The blade, punch and spring have been reinforced by heat treatment to be much more durable.

The handle guard avoids to get pinched.

Ergonomic pliers with bi-material handles.

Easy maintenance : made of few parts, which makes the tool cleaning much easier.

To cut and to punch natural slate 7 mm thick.

**MAT**

## SLATE CUTTING AND PUNCHING PLIERS

**2 in 1 = slate cutting and punching.**

No breathable dust, no crumbling.

Ergonomic and bi-material grip.

To cut and punch natural and man made slate max. 7 mm thick.

	MAT	MAT 2
Ref.	031055	032455
Blade	35 mm	55 mm



### MAT COUP

## SLATE CUTTING PLIERS

No dust, no crumbling.

Ergonomic and bi-material grip.

To cut natural and man made slate max. 7 mm thick.

	MAT COUP	MAT COUP 2
Ref.	032055	032555
Blade	35 mm	55 mm

Ref. : 523100  
SPARE SPRING FOR  
MASTERCUT



Ref. : 523101  
SPARE PUNCH FOR  
MASTERCUT



Ref. : 031755  
SPRING FOR MAT COUP  
AND MAT COUP 2  
x 5 pcs.



Ref. : 231155  
BLADE FOR MAT AND  
MAT COUP



Ref. : 232655  
BLADE FOR MAT 2  
AND MAT COUP 2



Ref. : 031255  
PUNCH FOR MAT  
AND MAT 2



Ref. : 031555  
REPAIR KIT FOR MAT  
AND MAT 2





## SLATER'S ANVIL

**400 mm**

All edges polished.  
Straightened.  
Curved tip.

	RIGHT HANDED	LEFT HANDED
Ref.	032155	032255



## "FRENCH" SLATER'S HAMMER

Hand forged.  
Leather handle.  
Nail puller.  
Polished finish.

	RIGHT HANDED	LEFT HANDED
Ref.	038155	038255

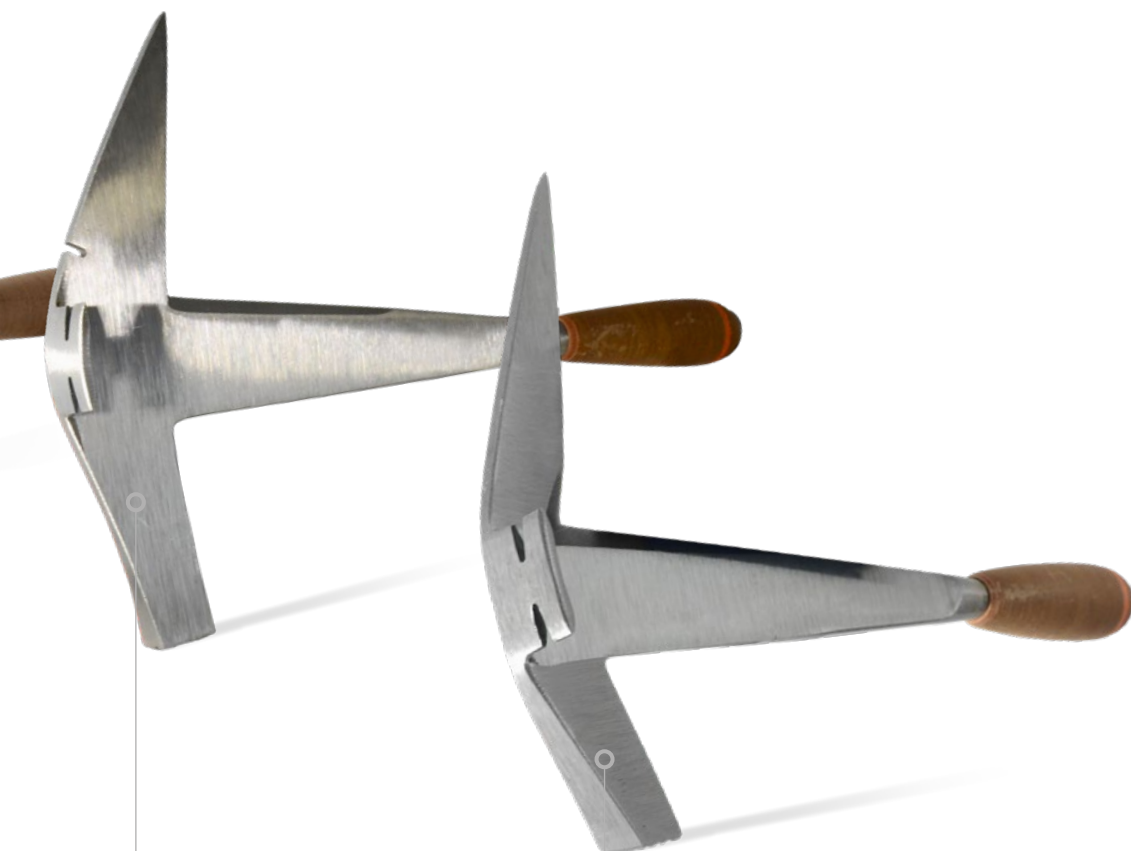

## “TRADITIONAL” SLATER’S HAMMER

Hand forged.  
Leather handle.  
Large face.  
Nail puller.  
Polished finish.

	RIGHT HANDED	LEFT HANDED
Ref.	038355	038455

## “UNIVERSAL” SLATER’S HAMMER

Hand forged.  
Left and right bevel.  
Leather handle.  
Nail puller.  
Polished finish.

	RIGHT HANDED	LEFT HANDED
Ref.	039655	139655



## SLATE RIPPER

Traditional slate ripper.  
Welded.  
Made of steel.

	400 MM	600 MM
Ref.	037655	037755



Ref. : 131255

## BEVEL

200 mm wooden handle.  
Adjustable angle measurement.



Ref. : 131355

## BRACKET

Made of aluminium.





Ref. : 032955

## COMPASS

250 mm

Forged high quality compass.  
Hardened and polished steel tips.



Ref. : 036155

## SCRIBER TOOL

Stainless steel tracing template.  
Graduations from 5 to 100 mm (from 5 to 5 mm).



Ref. : 033155

## ZINC AND LAMINATE SCRIBER

Tungsten carbide tip, ultra-resistant.  
Folding, cutting and marking of zinc  
and laminate sheets.





Ref. : 010755 **FLYER'S**

## FORGED AVIATION SNIP

Drop forged chromium molybdenum steel jaws.

Effortless cut.

Blade length : 42 mm.

Handle spring.

One hand automatic latch release.

Finger guard.



### CUTTING CAPACITIES

Stainless steel	0,8 mm
Soft metal	1,2 mm



Ref. : 010655 **FLYER'SL 75**

## FORGED AVIATION SNIP

**75 mm long blades**

Special for zinc.

Drop forged chromium molybdenum steel jaws.

Powerful and long lasting handle spring.

One hand automatic latch release.

Finger guard.



### CUTTING CAPACITIES

Stainless steel	0,8 mm
Soft metal	1,2 mm

Ref. : 109055  
**Left cut**



Ref. : 010955  
**Right cut**



## APOLLO

### FORGED AVIATION SNIP

Articulated tin snip.  
Drop forged chromium molybdenum steel jaws.  
Blade length : 35 mm.  
Handle spring.  
One hand automatic latch release.  
Finger guard.

#### CUTTING CAPACITIES

Stainless steel	0,9 mm
Blue sheet steel	1 mm
Galvanised sheet, zinc	1,2 mm
Copper, brass, sheet metal	1,5 mm
PVC, aluminium	2 mm
Polycarbonate	2,5 mm

Ref. : 102055  
**Left cut**



Ref. : 010255  
**Right cut**



## UPPER-CUT

### SHEARS "PASSE-FRANC"

Tin snip with offset blades.  
Drop forged chromium molybdenum steel jaws.  
Blade length : 35 mm.  
Handle spring.  
One hand automatic latch release.  
Finger guard.

#### CUTTING CAPACITIES

Stainless steel	0,9 mm
Blue sheet steel	1 mm
Galvanised sheet, zinc	1,2 mm
Copper, brass, sheet metal	1,5 mm
PVC, aluminium	2 mm
Polycarbonate	2,5 mm

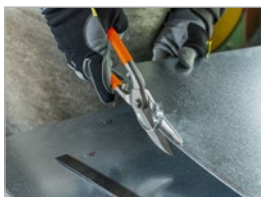

Ref. : 012055

## UNIVERSAL FORGED SHEARS

### 250 mm

Wide and narrow blade shears.  
Carbon steel.

For straight cuts and long curves.

Blade length : 67 mm.

56 HRC long life blades.

Handles with PVC dipping (thermal insulation).

#### CUTTING CAPACITIES

Stainless steel	1 mm
Galvanised sheet, zinc	1,2 mm

Ref. : 126055  
**Left cut**



Ref. : 012655  
**Right cut**



## FORGED SHEARS PELICAN

### 300 mm

Carbon steel.

Specially designed for long straight cut.

Blade length : 62 mm.

56 HRC long life blades.

Handles with PVC dipping (thermal insulation).

#### CUTTING CAPACITIES

Stainless steel	1,2 mm
Galvanised sheet, zinc	1,8 mm





## FIGURE HOLE FORGED SHEARS

### 250 mm

Carbon steel.  
 For straight cuts and short curves.  
 Blade length : 42 mm.  
 56 HRC long life blades.  
 Handles with PVC dipping (thermal insulation).

#### CUTTING CAPACITIES

Stainless steel	1 mm
Galvanised sheet, zinc	1,5 mm



## OFFSET FORGED SHEARS

### 260 mm

Carbon steel.  
 For long straight cuts and long curves.  
 Blade length : 30 mm.  
 56 HRC long life blades.  
 Handles with PVC dipping (thermal insulation).

#### CUTTING CAPACITIES

Stainless steel	1 mm
Galvanised sheet, zinc	1,5 mm



Ref. : 011055 **SUPERCOU**

## NIBBLER SHEARS

**With built-in waste curl cutter**

For flat sheet metal.

### CUTTING CAPACITIES

Stainless steel	0,8 mm
Galvanised steel, zinc, sheet metal	1,2 mm
PVC, vinyl flooring, aluminium	2 mm



Ref. : 105055  
**BLADE**



Ref. : 111055  
**CUTTING UNIT**



Ref. : 010155 **NIBBLER SHEARS NRI**

## NIBBLER SHEARS

For flat sheet metal.

Perfect for cutting stud and track.

### CUTTING CAPACITIES

Stainless steel	0,6 mm
Galvanised steel, zinc, sheet metal	1,2 mm
PVC, vinyl flooring, aluminium	2 mm



Ref. : 101055  
**BLADE**





Ref.: 011355

**SUPERCOUPE NR3**

## NIBBLER SHEARS SPECIAL CORRUGATED IRON

**With built-in waste curl cutter**

Special for corrugated metal.

### CUTTING CAPACITIES

Stainless steel	0,6 mm
Galvanised steel, zinc, sheet metal	1,2 mm
PVC, vinyl flooring, aluminium	2 mm



Ref.: 103055  
**BLADE**



Ref.: 038955

**TURBOSHEAR**

## ADAPTABLE SHEARS ON CORDLESS POWER DRILLS/SCREWDRIVERS

*Neat, quick and easy cut.*

Minimum 14.4 V - 2 Ah power drill/screwdriver.

Single handed operation.

Can be used upside down.

### CUTTING CAPACITIES

Stainless steel	0,9 mm
Galvanised steel, zinc, copper	1,5 mm
Aluminium	2 mm



Ref.: 138955  
**SPARE BLADES KIT**



Ref. : 017255 **NIBBLEX® UNIVERSAL**

## ADAPTABLE NIBBLER SHEARS ON CORDLESS POWER DRILLS/ SCREWDRIVERS

**Neat and quick cut.**

For flat or corrugated metal and PVC surfaces.

Speed 300 rpm minimum.

Multidirectional die.

### CUTTING CAPACITIES

Stainless steel	0,8 mm
Galvanised steel, zinc, sheet metal, copper, brass	1,5 mm
PVC, vinyl flooring, aluminium	2 mm
Polycarbonate	2,5 mm



Ref. : 017455  
**PUNCH + DIE SET**

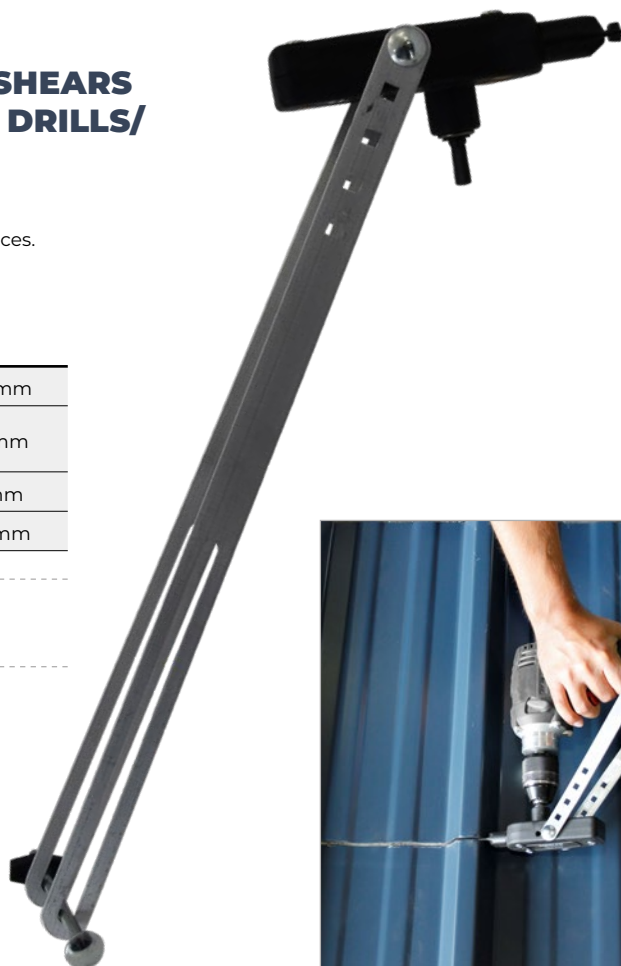

Ref. : 133055

## NIBBLER HAND NOTCHER

Notch dimensions : 33 mm x 3 mm.

Neat cut.

Max. capacity on zinc : 0.8 mm thickness.



Ref. : 034155 **INTERPERFOR**

## NOTCH PUNCHING MACHINE

**3,5 x 15 mm**

Ideal for vinyl coated cladding sheet, zinc or aluminium.  
Makes a notch of 3.5 x 15 mm to prevent buckling.  
Depth of 9 to 21 mm from the oblong axis.



### NOTCHING CAPACITIES

Zinc, sheet metal cladding	0,8 mm
Plastic	1 mm



Ref. : 039055  
**PUNCH + DIE**



Ref. : 018555 **POLYPERFOR**

## PUNCHING MACHINE

**Sheet metal and slate**

Punching power : 740 kg.  
Precise graduation opening to max. 8 mm.  
Adjustable depth guide up to 43 mm.

### Supplied with 5 punches

Sheet metal	Ø 3,3 mm
Slate	Ø 3,3 mm
Steel suspension wires	Ø 4,1 mm
Threaded rod	Ø 4,9 mm and Ø 6,2 mm

**Applications :** roofing, suspended ceilings etc.



PUNCH DIAMETER	Ø 3,3 MM	Ø 4,1 MM	Ø 4,9 MM	Ø 6,2 MM
Stainless steel	1,2 mm	1 mm	0,8 mm	0,5 mm
Sheet metal	1,5 mm	1,5 mm	1,2 mm	0,8 mm
Aluminium	3 mm	2 mm	2 mm	1,5 mm



Ref. : 018455  
**PUNCH SET**

Ø 3,3 mm, Ø 4,1 mm, Ø 4,9 mm, Ø 6,2 mm.



Ref. : 130455

**4 rolls**

4 guide rolls = special long sheets.  
Possibility of separating the tool to get two single benders with 2 rolls (ref. 130355).

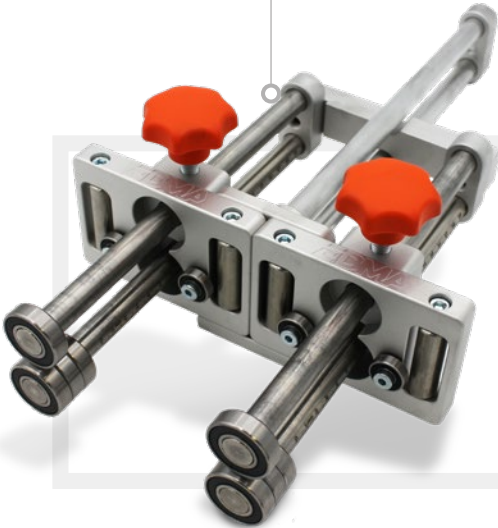

Ref. : 130855

**8 rolls**

8 guide rolls = special long sheets.  
Possibility of separating the tool to get two single benders with 4 rolls (ref. 130155).



**DOUBLE BENDER**

**Tool to make folds, counterfolds, raised areas on sheets**

Machine to make edging and bending of sheet metal.  
For zinc, aluminium, soft metal, stainless steel.  
Height from 5 mm up to 200 mm.

**FOLDING CAPACITIES**

Stainless steel	0,5 mm
Steel, sheet metal	0,7 mm
Copper	0,8 mm
Zinc, aluminium	1 mm





#### 4 rolls

With aluminium handle.

Ref. : 130955    **350 mm**    Folding depth : 350 mm.

Ref. : 130155    **200 mm**    Folding depth : 200 mm.

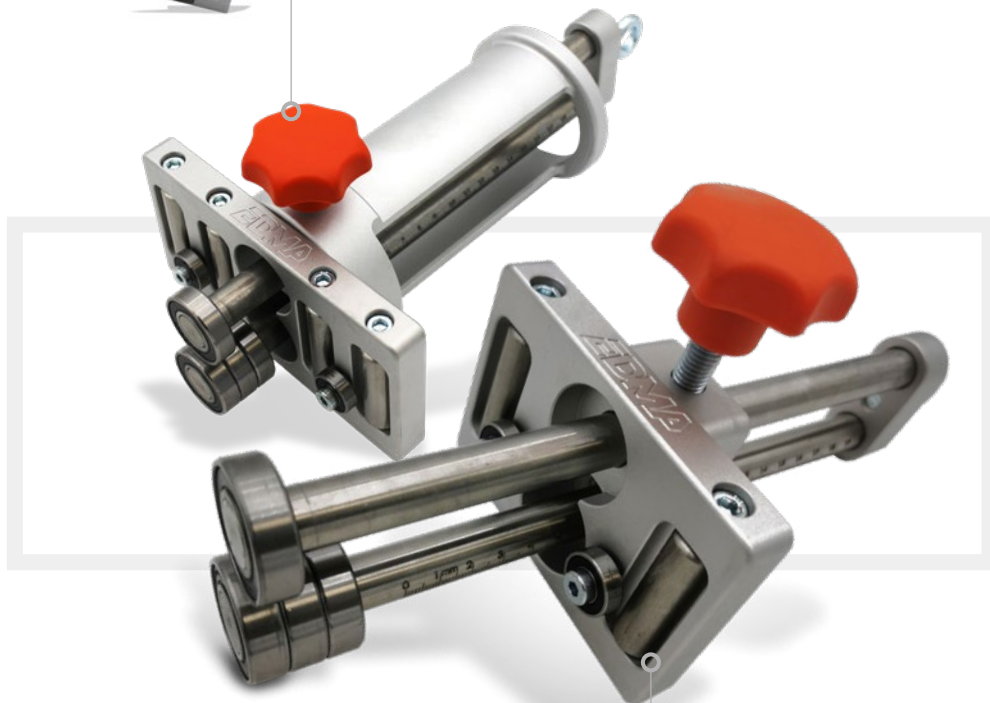

## SINGLE BENDER

**Tool to make folds, counterfolds, raised areas on sheets**

Machine to make edging and bending of sheet metal.

Faster than clinching pliers.



Ref. : 130355

**2 rolls**

Folding depth : 200 mm.

#### FOLDING CAPACITIES

Stainless steel	0,5 mm
Steel, sheet metal	0,7 mm
Copper	0,8 mm
Zinc, aluminium	1 mm



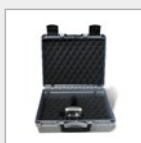

Ref. : 130755

## EDGE ROLLER

**25 mm**

**Tool to make bends from 90° to 180° max.**

For curved fold.  
 Graduated in cm and inches.  
 Handle with leverage effect.  
 Height of raised areas continuously adjustable from 5 to 25 mm.

### FOLDING CAPACITIES

Stainless steel	0,5 mm
Steel, sheet metal	0,7 mm
Copper	0,8 mm
Zinc, aluminium	1 mm



## DISK ROLLER

**Tool to make bends from 90° to 180° max.**

From 8 mm to 40 mm high.  
 Maximum thickness : 1 mm.  
 Tool ready to work : no adjustment necessary.



Ref. : 130255

## SINGLE DISK ROLLER





## FOLDING CAPACITIES

Stainless steel	0,5 mm
Steel, sheet metal	0,7 mm
Copper	0,8 mm
Zinc, aluminium	1 mm



Ref. : 230255

## DISK ROLLER WITH RETRACTABLE STOPPER

Retractable stopper to get out  
the tool while folding.

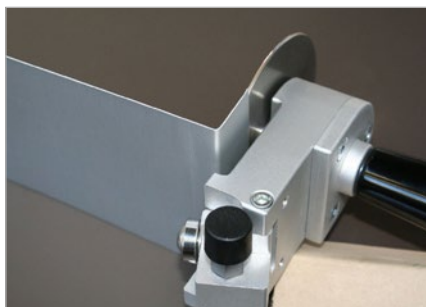

Ref. : 130655

## DOUBLE DISK ROLLER





## CLINCHING PLIERS

### Straight

Lap joint.

Handles with PVC dipping (thermal insulation).

WIDTH	22 MM	60 MM	80 MM	100 MM
Ref.	039155	039355	039455	039555
Folding depth	32 mm	54 mm	54 mm	66 mm



## CLINCHING PLIERS

### Bent of 45°

Lap joint.

Handles with PVC dipping (thermal insulation).

WIDTH	22 MM	60 MM	80 MM
Ref.	034255	034455	034555
Folding depth	20 mm	45 mm	50 mm





Ref.: 034855

## CLINCHING PLIERS

**Bent of 90°**

Lap joint.

Handles with PVC dipping (thermal insulation).



<b>WIDTH</b>	<b>60 MM</b>
Folding depth	55 mm



## SEAMING PLIERS

**Straight**

Lap joint.

Raise large and deep measure.

<b>WIDTH</b>	<b>180 MM</b>	<b>200 MM</b>
Ref.	030555	030655
Folding depth	175 mm	185 mm

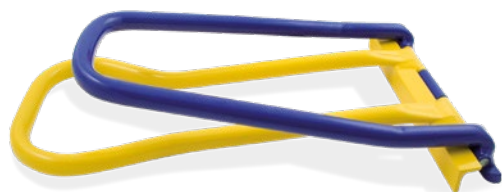

Ref. : 038655

## SQUARE SEAM FOLDER

Operated square seam folder joins SPM 30/80 profiles.

### SPECIFICATIONS

Tool width	220 mm
Claw height	50 mm

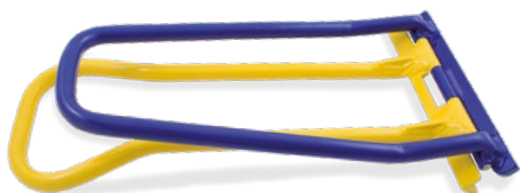
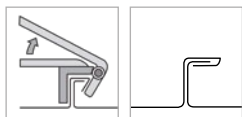

Ref. : 038755

## TWIN SQUARE SEAM FOLDER

Allows simple and quick shaping of locked square seam into double-seam in just one operation.

### SPECIFICATIONS

Tool width	220 mm
Claw height	50 mm



Ref. : 132555

## SEMI-CIRCULAR DORMER SQUARE SEAM FOLDER

Tool joining prefabricated SPM-profiles. Square seam folding without hammering. Recommended for joining flat or curved prefabricated profiles at intervals.

### SPECIFICATIONS

Tool width	65 mm
Claw height	55 mm

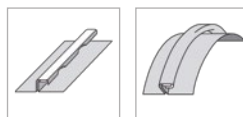

Ref. : 131155

## SEAM OPENING PLIERS

Seam and gutter opening pliers. Forged steel head. Head length : 30 mm. Handles with PVC dipping (thermal insulation).



Ref. : 135955

## EAVES EDGER 105 TK

Allows quick and accurate sheet metal shaping constructing eaves, gutters, dormer windows etc...

Can be rotated 90°, even if the gutter is already installed.



### SPECIFICATIONS

Tool width	250 mm
Claw height	30 mm



Ref. : 132355

## EAVES CLOSING JAWS

Fastening without hammering.

### SPECIFICATIONS

Tool width	220 mm
Claw height	50 mm



Ref. : 132255

## TILE EDGER

To build any slope for tile edges.  
Supplied with a 200 cm measuring tape.

### SPECIFICATIONS

Tool width	70 mm
Claw height	40 mm

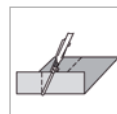

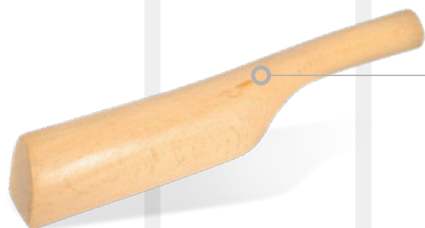

Ref. : 132155

### LEAD DRESSER

Asymmetrical shape.  
For zinc and lead work.  
Its flat shape allows flattening, metal forming and bending.



Ref. : 132755

### BENDING STICK

Round, bent shape.  
For zinc and lead work.  
Allows customized shaping.

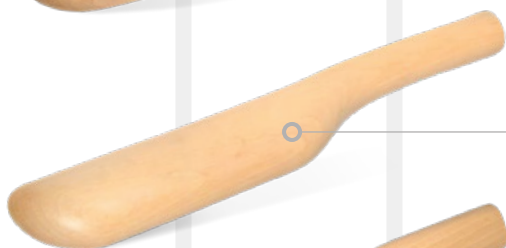

Ref. : 132655

### BOSSING STICK

Slim, rounded shape.  
For zinc and lead work.  
Allows regular bending.

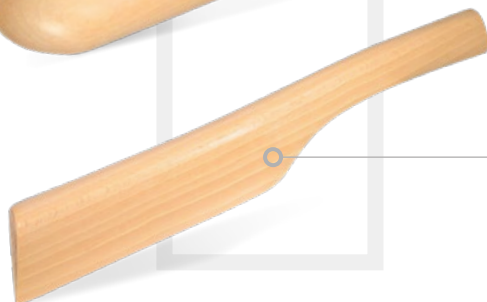

Ref. : 132855

### SETTING STICK

Slim, straight shape.  
Allows modelling and shaping of lead, copper, aluminium, zinc and other soft metals.



Ref. : 037255

### GROOVING HAMMER

1 round face and bent edge.  
Polished finish.  
Allows metal to be shaped, stretched or flattened.





## TINMAN'S MALLET

Made of PVC, limiting marking on the metal during use.



Ref. : 033955

### Angular

Head dimensions :  
85 x 40 x 150 mm.



Ref. : 233955

### Rectangular

Head dimensions :  
145 x 35 x 75 mm.

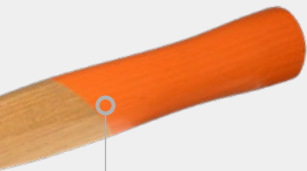

Ref. : 135255

## GROOVING HAMMER DIFFERENT FACES

Fine polished finish.  
Faces differently bent.  
One vertical face.  
One horizontal face.  
Allows precise shaping of  
metal.



Ref. : 135355

## DEAD BLOW SOFT FACED HAMMER

Diameter : 32 mm.  
Polished finish.  
Lacquered.  
Curved.  
Head of shock-resistant nylon.  
Allows metal parts to be  
straightened, shaped and  
assembled without marking.



Ref. : 035155  
**SEAMING IRON**  
**With flat blade**

Forged steel.  
 Block height: 25 mm.  
 Long blade.  
 Block with  $\varnothing 5 \times 15$  mm hole.



Ref. : 035255  
**DOUBLE**  
**SEAMING IRON**

Forged steel.  
 Block height 25 and 35 mm.



Ref. : 035455  
**FOLDING TOOL**  
**«Squeezing folding pliers»**

Special forged steel.  
 Depth : 140 mm.

Ref. : 036455  
**ROOFER'S**  
**HOLDER**

**Soldering iron tip**  
**cleaning set**

Special for zinc.  
 Ammonia salt stripping  
 stone, cleaning brush and  
 plastic container.  
 Stripper not included.



Ref. : 136455  
**BAG OF 25 BRUSHES**



Ref. : 236455  
**STRIPPING STONE**

Ref.: 131855

## GUTTER HANGER BENDER

Head made of malleable casting GTW 40.  
Steel tubes with plastic handles.



### MAX. CAPACITIES

Width	40 mm
Thickness	8 mm

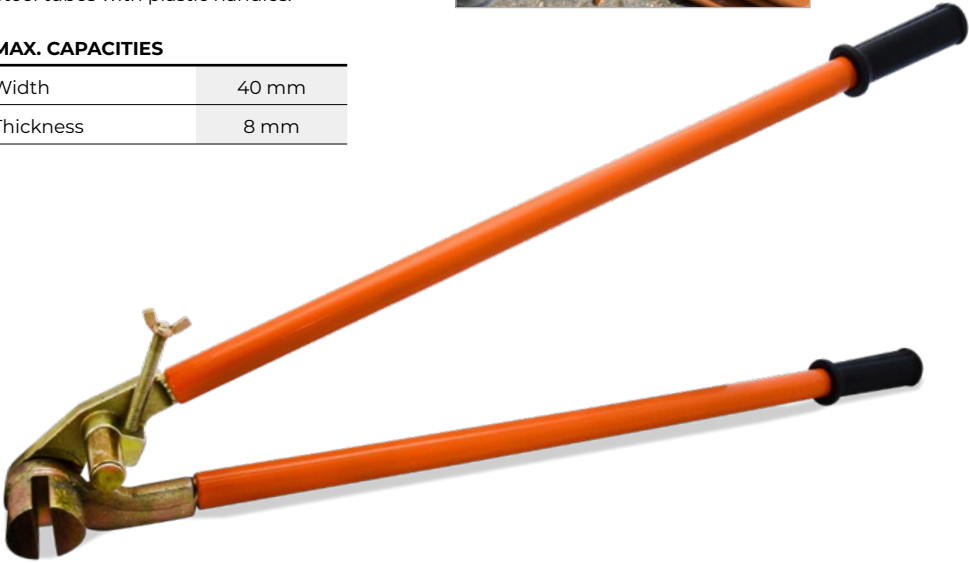

Ref.: 036055

### INTERCLIPS ZINC

## CLINCHING PLIERS FOR ZINC OR ENAMEL-PLATED ALUMINIUM GUTTERS

*Quick* and strong fixing.

6 x 3 mm crimp.

For zinc or enamel-plated aluminium gutters, edge strip.  
Depth of 5 to 20 mm.

### CLINCHING CAPACITIES

Zinc, aluminium	0,8 mm
Sheet metal	0,75 mm

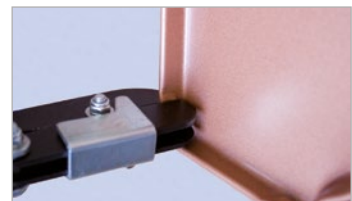



Ref.: 035055 **MAXI-RET®**

## EFFORTLESS SWAGING TOOL

**5 blades**

Pipe crimping tool for all types of metallic pipes. Special for stainless steel pipes up to 0.8 mm. Progressive reduction of the pipe diameter. Swaging by 52 mm with 2 impressions in 1 press.



Ref.: 031755  
**SPRING**  
x 5 pcs.



Ref.: 030055

**5 blades**

Swaging by 30 mm with 2 impressions in 1 press.



Ref.: 030355

**3 blades**

Special for square pipes. Swaging by 30 mm.

**RET**

## SWAGING TOOL

Pipe crimping tool for all types of metallic pipes.



Ref. : 050155

## PIPE POSITIONER

### Small variable angle vice

From 8 to 30 mm diameter tubes.  
To weld all pipes, sections and wrought iron.  
Variable arms span up to 60 mm.



Ref. : 134955

## WELD SEAM TESTER

Ergonomical wooden handle.  
90° angled.



Ref. : 135055

## SCISSORS SPECIAL FOR PLASTIC SHEETS

For roof and sealing sheets.  
Polished blades.  
Varnished black.  
250 mm blades.



Ref. : 135155

## PLASTIC BOTTLE

### 500 ml

LDPE transparent.  
Screw cap and angled brush attachment.



## PRESSURE ROLLER

2 enclosed smooth-running ball bearings.  
Silicone roller.  
Bolted axis.  
Ergonomical wooden handle for maximum pressure.  
Bracket one-sided.  
For overlap welding.  
Ø 33 mm.



Ref. : 134255  
**28 mm width**



Ref. : 134355  
**45 mm width**



Ref. : 134455  
**45° angled**  
**45 mm width**



Ref. : 134655

## PRESSURE ROLLER

Plain bearing.  
Silicone roller.  
Riveted axis.  
Ergonomical wooden handle.  
Bracketed on both sides.  
For overlap welding.  
Ø 33 mm.



**90 mm width**

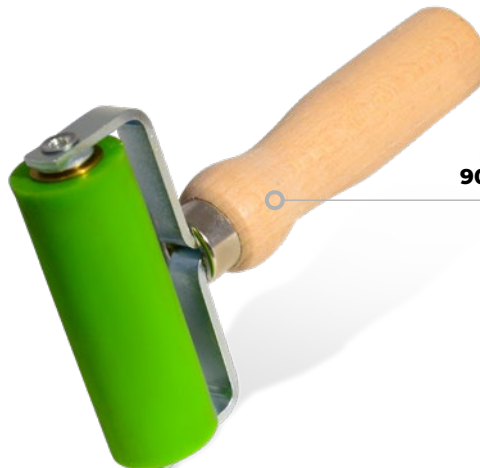



Ref. : 234355

## ERGONOMIC PRESSURE ROLLER

Ergonomic design to provide maximum pressure and to avoid musculoskeletal disorders.

2 enclosed smooth-running ball bearings.

For overlap welding.

Silicone roller.

Ø 33 mm.

45 mm width



Ref. : 134555

## BRASS PRESSURE ROLLER

Enclosed smooth-running ball bearing.

45° angled.

Ergonomical wooden handle.

Ø 28 mm.

6 mm width



## STEEL PRESSURE ROLLER

2 enclosed smooth-running ball bearings.

Steel roller.

Heavy duty design.

Ergonomical wooden handle.

For cold pressure welding.

Ø 40 mm.

Ref. : 134755

40 mm width



Ref. : 134855

60 mm width



## TILE LIFTER

Quick adjustment system.  
 Ideal to easily carry tiles.  
 Centered handle whatever the width of tile to carry.

ADJUSTABLE FROM	280 TO 665 MM	280 TO 800 MM
Ref.	269055	369055
Max. carried load*	35 kg	50 kg

\*Test performed by  on a 40 cm x 40 cm tile.



Ref.: 039855 **CLIN FIX®**

## CLADDING SUPPORTS

Set of 2 pieces.

To install overlap claddings (fiber cement, fiber wood or wood) by 1 person alone.

Allows to hold planks in position before nailing with overlap of 30 mm.

For all claddings from 6 mm to 16 mm thick.

Adjustable for different widths of clinkers from 160 mm to 255 mm.

### EXAMPLES OF FIBER-CEMENT WIDTH

Hardie Plank type	180 mm
Cedral type	190 mm
Duracolor type	210 mm
Hardie Linea type	210 mm
Ced'R-Tex type	225 mm



Ref. : 037055

**ALPHACUT**

## GUILLOTINE TO CUT FIBER CEMENT SIDING

*Neat* cut without any effort.

No sharpening required ever on blade.

No breathable dust.

No noise.

### CUTTING CAPACITIES

Max. width	210 mm
Max. thickness	11 mm



Ref. : 089955

**VARIOCUT**

## **GUILLOTINE TO CUT FIBER CEMENT SIDING**

*Neat* cut without any effort.

Special for length cuts.

No sharpening required ever on blade.

Possible cuts from 0° to 90°.

No breathable dust.

No noise.

### **CUTTING CAPACITIES**

Max. width for straight cutting	320 mm
Max. width for angular cutting	210 mm
Max. thickness	12 mm

### **Also includes :**

- 1 trestle.
- 1 waste collector.





Ref. : 230155 **TURBOSHEAR FIBER CEMENT**

## ADAPTABLE FIBER CEMENT SHEARS ON CORDLESS POWER DRILLS/ SCREWDRIVERS

*Clean* and easy cut on fiber cement panels (such as Aquapanel® Outdoor).

Fits all types of power drills/screwdrivers (from 14,4 V).

Max. cutting thickness : 12,5 mm.

Produce minimal dust.

360° rotating head secures in any position for optimum tool clearance.



Ref. : 073155 **TRIOCOUP'**

## PIPE CUTTING TOOL

Ø 16, 20 and 25 mm

**Effortless and clean cut without distortion nor burr.**

Replaceable stainless steel blade with double sharpening.

Auto-locking barrel, 3 cutting slots.

Rotation of the barrel to select the cutting diameter.

Allows the cutting of plastic pipes (PVC, PER, ICTA, IRL, IRO) and multilayer pipes.



Ref. : 073255  
**STAINLESS STEEL  
BLADE**





Ref.: 065955 **RODCUT**

## **ROD GUILLOTINE**

**Ø 6, 7, 8, 10 mm**

*Clean cut* = immediate bolting.

No noise.

Can be used to repair damaged threaded rod.

No waste (no metal filings).

No sparks - No risk of fire - No special permit.

M7 rod (7 mm diam.) 150 threaded rods, can be cut

on 10 mm diam. slot : special for heating, ventilation,  
air-conditioning and sanitary engineers.

Up to 6.6 soft steel : 60 kg/mm<sup>2</sup>.

Cannot cut stainless steel threaded rod.

650 mm adjustable cutting guide can be positioned  
on the right or left.



Ref.: 165955  
**REPLACEABLE DIE**



Ref. : 038855 **MINI RODCUT M8**

## **ROD GUILLOTINE**

**Ø 4, 6 and 8 mm**

*Clean* cut = immediate bolting.

No noise.

Can be used to repair damaged threaded rod.

No waste (no metal filings).

No sparks - No risk of fire - No special permit.

Up to 6.6 soft steel : 60 kg/mm<sup>2</sup>.

Cannot cut stainless steel threaded rod.

545 mm adjustable cutting guide can be positioned on the right or left.



Ref. : 138855  
**REPLACEABLE DIE**

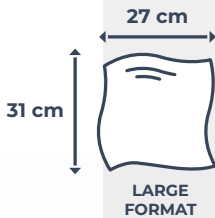

Ref : 260655

## HAND AND SURFACE CLEANING WIPE

**x 90 pcs**

### **No rinsing, drying or residue.**

Safe for the epidermis, the wipe has a strong cleaning and detergent power.

Effective on hands as well as on smooth, non-porous surfaces such as worktops, tools, machines, computers, copiers/fax, whiteboards, car interiors, wheel rims.

Removes ordinary dirt as well as hard greases, fresh paints, adhesives, oils, lubricants, sludge, inks, waxes, bitumen, tar and other stubborn stains such as coal, graphite and grass marks.

**Composition :** vegetable solvents combined with an abrasive towel, which does not scratch.

Classified in cosmetic products.



# MASON RANGE

## **SPEED OF EXECUTION, SOLIDITY OF ACHIEVEMENTS**

EDMA's range of specific tools for mason is designed to give users a real time and effort saving on daily work.

Find out the entire range of must-have specific tools for time-saving masonry you need.





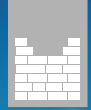

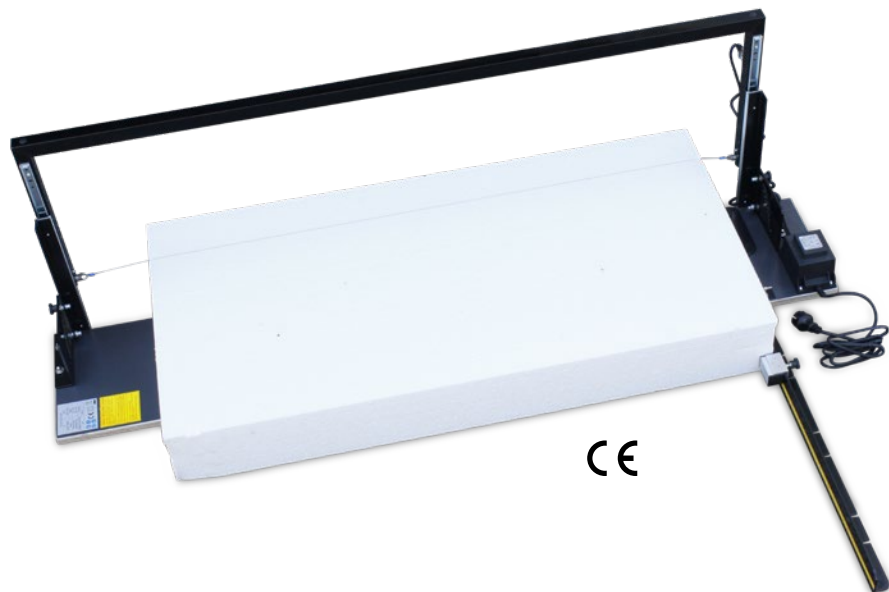

CE

Ref. : 260155

## HORIZONTAL HOT WIRE CUTTING TABLE

**For polystyrene***Clean* cut without polystyrene beads projection.

For expanded and extruded polystyrene (E.P.S. and X.P.S.).

Transformer : 40 V / 200 W / 230 V.

CE certified.

### SPECIFICATIONS

Max. cutting depth	330 mm
Max. cutting width	1 320 mm
Angle cut	from 0 to 90°
Chamfered cut	from 90 to 15°

#### Possible cutting shapes :

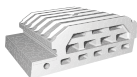
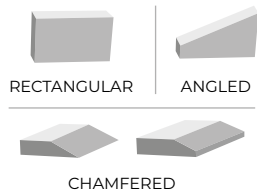

IDEAL FOR  
CUTTING  
POLYSTYRENE  
SLABS



Ref. : 266855  
**1370 MM SPARE CUTTING WIRE**



Ref. : 267155  
**TRANSFORMER**



Ref. : 526666  
**PACK LITHIUM BATTERY**  
Composed of a 36 V - 2 Ah lithium battery and its charger + a battery rack to connect to the machine.



Ref. : 526665  
**SPARE BATTERY**  
Lithium battery 36 V - 2 Ah.



Ref. : 526793  
**BATTERY CHARGER**  
For lithium battery 36 V - 2 Ah.



CE

Ref. : 267955

**Battery operated**  
for greater freedom  
of work



Ref. : 266655

CE



## HOT WIRE CUTTING BOW

For polystyrene

*Clean* cut without polystyrene beads projection.

For expanded and extruded polystyrene (E.P.S. and X.P.S.).  
CE certified.

HOT WIRE CUTTING BOW	BATTERY OPERATED	MAINS OPERATED
Ref.	267955	266655
Max. cutting depth	330 mm	330 mm
Max. cutting width	1 370 mm	1 370 mm
Power supply	Lithium battery 36 V - 2 Ah	Transformer 40 V / 200 W / 230 V

Possible cutting shapes :



RECTANGULAR



ANGLED

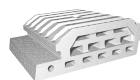

IDEAL FOR CUTTING  
POLYSTYRENE  
SLABS



Ref. : 266855  
**1370 MM SPARE CUTTING WIRE**



Ref. : 267155  
**TRANSFORMER**



Ref. : 526665  
**SPARE BATTERY**  
Lithium battery 36 V - 2 Ah.



Ref. : 526793  
**BATTERY CHARGER**  
For lithium battery 36 V - 2 Ah.



CE

**Battery operated** for greater freedom of work



**STYROGUN** **NEW**

## **CORDLESS HOT WIRE CUTTER**

**For polystyrene**

*Clean* cut without polystyrene beads projection.

For expanded and extruded polystyrene (E.P.S. and X.P.S.).

Allows a multitude of precise and fast cuts thanks to its linear translation guide.

Grooving possible thanks to its adjustable depth stop.

Optimized mobility on the worksite : cordless, compact design, light weight.

CE certified.

<b>STYROGUN</b>	<b>WITH BATTERY AND CHARGER</b>	<b>WITHOUT BATTERY OR CHARGER</b>
Ref.	368455	368401
Max. cutting height	630 mm	630 mm
Max. cutting depth	310 mm	310 mm
Adjustable linear guide for angled cuts	from 0 to 45°	from 0 to 45°
Lithium battery	18 V - 2 Ah	18 V - 2 Ah (sold separately)

### **ACCESSORIES INCLUDED**

Carrying case	1	1
Battery + battery charger	1	--
Cutting wires	3	3

#### **Possible cutting shapes :**

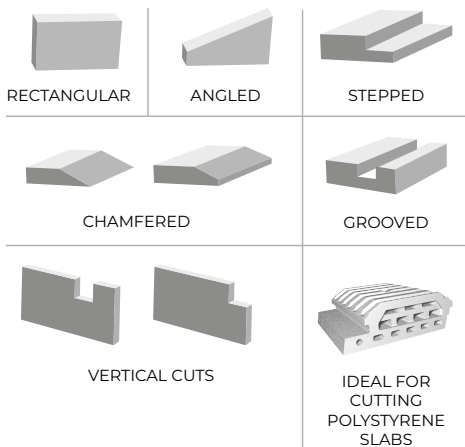

Ref. : 536841  
**678 MM SPARE CUTTING WIRE**



Ref. : 536831  
**SPARE BATTERY**  
Lithium battery 18 V - 2 Ah.



Ref. : 536832  
**BATTERY CHARGER**  
For lithium battery 18 V.



Ref. : 536843  
**DUAL BATTERY CHARGER**  
For lithium battery 18 V.



Ref. : 536840  
**PACK 2 BATTERIES**  
**18 V - 2 AH**  
**+ DUAL CHARGER**

Ref. : 283155 **EDMARKER** **NEW**

## CONSTRUCTION PENCIL WITH RETRACTABLE LEAD

Allows marking on a wide range of surfaces and materials, such as : concrete, tiles, metal, wood, parquet...

ABS and stainless steel for strength and durability.

Push-button with integrated sharpener.

Ergonomic design facilitates marking in tight areas or through holes.

Practical storage holster with belt clip.

Easy-to-clean markings.

Supplied with one lead  $\varnothing$  2.8 x 120 mm, in grey 2B graphite.

Can be fitted with colored leads (sold separately).



Ref. : 283255  
**GREY LEAD**  
**x 6 pcs**  
Made of 2B graphite.



Ref. : 283355  
**COLOR LEAD**  
**x 6 pcs**  
1 grey 2B graphite lead.  
5 wax leads : white, orange,  
yellow, blue and red.

Dimensions :  $\varnothing$  2.8 x 120 mm.  
Suitable for marking on a wide range of  
surfaces and materials, such as : concrete,  
tiles, metal, wood, parquet...



## MAGNETIC TAPE MEASURE

*Magnetic* double hook for easy measuring.

Nylon-coated tape protected against dust and water.

Double marking : horizontal and vertical reading.

Class II accuracy.

Ergonomic and compact design.

Reinforced and anti-slip case.

Equipped with 2 buttons: braking and locking of the  
tape.

Belt hook + leash.

### DIMENSIONS

Ref. : 175555	5 m x 25 mm	
Ref. : 175855	8 m x 25 mm	<b>N</b>

Complies with the applicable essential requirements  
of Directive 2014/32/EU of the European Parliament  
and of the Council of 26 February 2014, Module D1.



Ref. : 175055

## TAPE MEASURE

**5 m x 25 mm**

Antishock rubber box.

Nylon coated tape protected against dust and water.

Class II accuracy.

Equipped with 2 buttons: braking and locking of the  
tape.

Belt hook + leash.



Complies with the applicable essential requirements  
of Directive 2014/32/EU of the European Parliament  
and of the Council of 26 February 2014, Module D1.

Ref. : 060755 **ALU LINE**  
**ALUMINIUM CHALK**  
**LINE REEL**  
**30 m**



Built-in filter system to prevent excess chalk.  
 Rope diameter: 1 mm.  
 Capacity: 80g.

Ref. : 060555 **FAST LINE**  
**FAST REWINDING**  
**CHALK LINE REEL**  
**30 m**



Rewinds 5 times faster.  
 Built-in filter system to prevent excess chalk.  
 Rope diameter: 1 mm.  
 Capacity: 100 g.

Ref. : 060955 **MAX LINE**  
**CHALK LINE REEL**  
**WITH LARGE HANDLE**  
**50 m**



For long distance marking.  
 Built-in filter system to prevent excess chalk.  
 Rope diameter: 2,5 mm (braided).  
 Capacity: 300 g.



Ref. : 160555  
 Ø 1 MM BRAIDED  
 SPARE ROPE FOR  
 FAST LINE AND  
 ALU LINE



Ref. : 260555  
 Ø 2.5 MM BRAIDED  
 SPARE ROPE FOR  
 MAX LINE



## MARKING CHALK

WEIGHT	200 G	400 G	1 000 G	3 500 G
<b>BLUE</b> (Ref.)	063355	063255	063155	065255
<b>RED</b> (Ref.)	063855	064955	064355	065155

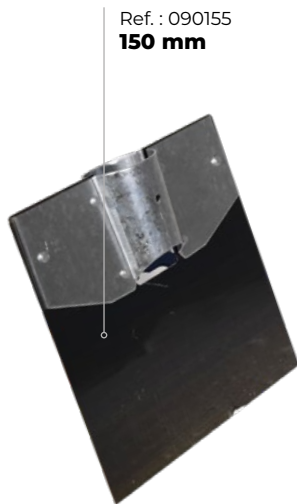

Ref. : 090155  
**150 mm**

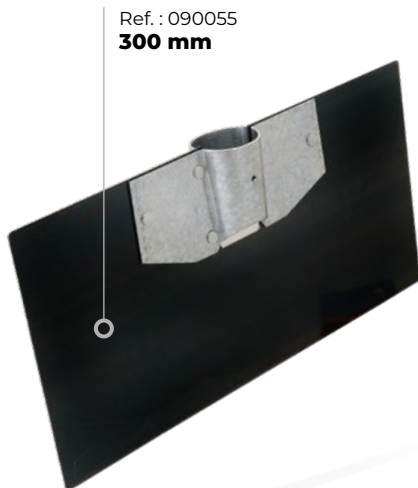

Ref. : 090055  
**300 mm**



Ref. : 095055  
**500 mm**

## HEAVY DUTY SCRAPER

**Hardened steel with riveted standard socket.**

36 mm conical shell to connect to wooden handle.  
Excellent rigidity.

**Examples of application :**

- To clean construction sites.
- To remove easily concrete dust, snow or ice.
- To remove carpet, linoleum, flooring underlay, adhesive remnants.



Ref. : 290255

## 110 CM WOOD HANDLE

Ø 32 mm

**For heavy duty scraper**







Ref. : 266955

## REBAR GUILLOTINE BENDER

Allows to cut and bend steel rebars.  
Double function : cutting and bending.

### SPECIFICATIONS

Max. diameter for cutting application	18 mm
Max. diameter for bending application	16 mm



## CORDLESS REBAR TYER

Light and *compact*.

Enables to quickly, efficiently and effortlessly, tie rebars together.

Automatic adjustment of tying power according to the rebars dimensions to tie.



CE



**Brushless motor** =  
efficiency and durability

### EDMATYER

**24 mm**

To be used with 100 m wire coils,  
i.e. around 260 ties/coil.

Capacity of tying links :  $\varnothing$  12 to 24 mm.



**Interchangeable tying head**  
= adaptability

CE

### EDMATYER XL

**40 mm**

To be used with 100 m wire coils,  
i.e. around 145 ties/coil.

Capacity of tying links :  $\varnothing$  26 to 40 mm.



	<b>EDMATYER</b>	<b>NEW</b> <b>EDMATYER</b> without battery or charger	<b>EDMATYER XL</b>	<b>NEW</b> <b>EDMATYER XL</b> without battery or charger
Ref.	367655	536807	367755	536808
Dimensions	300 x 225 x 68 mm		315 x 225 x 68 mm	
Weight (without battery)	1,2 kg		1,2 kg	
Voltage	14,4 V		14,4 V	
Ø links	12 to 24 mm		26 to 40 mm	
Tying speed	0,8 s		0,8 s	
Tying wraps	2		3	
No of links per full battery cycle	2 250 pcs		1 650 pcs	
Links per coil	Around 260		Around 145	
Battery - Ref. 536760	Lithium-Ion 14,4 V / 2 Ah		Lithium-Ion 14,4 V / 2 Ah	
Charging time	2,8 h		2,8 h	
Dual charger Ref. 536761	14,4 V / 2,9 A		14,4 V / 2,9 A	
<b>DELIVERED WITH</b>				
1 wire coil 100 m	✓	✓	✓	✓
2 batteries 14,4 V - 2 Ah	✓		✓	
1 double charger	✓		✓	
1 cutting pliers	✓	✓	✓	✓
1 allen key	✓	✓	✓	✓
1 carrying case	✓	✓	✓	✓



Ref. : 367855  
**CARTON OF  
20 WIRE COILS**



Ref. : 536760  
**SPARE BATTERY**  
Lithium battery  
14,4 V - 2 Ah.



Ref. : 536761  
**DUAL BATTERY CHARGER**  
For lithium battery  
14,4 V - 2 Ah.



Ref. : 536891  
**24 MM TYING HEAD**



Ref. : 536890  
**40 MM TYING HEAD**



Ref. : 049855 **TURBO 24**



## PNEUMATIC GUN FOR CL 24 STAPLE INSTALLATION

5-8 bar working pressure.  
Magazine capacity : around 100 CL 24 staples.

### Applications :

- Swimming pool formwork.
- Industrial fastening.



		<p><b>CL 24 STAPLE</b> Wire Ø: 1,8 mm.</p>	<p><b>10 000 PCS</b></p>
<p><b>GALVANIZED</b> Wire resistance : 650 - 750 N/mm<sup>2</sup>. Galvanized treatment.</p>			<p>Ref. 190000</p>



Ref. : 045555 **TORNADO**  
**AUTOMATIC BINDER FOR  
 LOOP TIE WIRE**

Allows to tie rebars, fencings, gravel bags.  
 Soft hand grip.



## LOOP TIE WIRE

Allows to fasten elements together.  
 To use with an automatic binder.

**For different kinds of fastening :**  
 rebar, fencing, gravel bags.

Approximative quantity per coil.



**Galvanized  $\varnothing$  1 mm**



**Annealed  $\varnothing$  1,1 mm**

LENGTH QUANTITY	100 MM	120 MM	140 MM	160 MM	180 MM	200 MM
--------------------	--------	--------	--------	--------	--------	--------

### GALVANIZED LOOP TIE WIRE

<b>1 000</b>	--	Ref.: 960452	--	--	--	--
--------------	----	--------------	----	----	----	----

### ANNEALED LOOP TIE WIRE

<b>1 000</b>	Ref. : 960457	Ref. : 960449	Ref. : 961480	Ref. : 960458	Ref. : 963453	Ref. : 962449
<b>2 500</b>	--	Ref. : 961449	Ref. : 961459	Ref. : 962458	--	--
<b>5 000</b>	--	Ref. : 960453	Ref. : 960459	--	--	--

Bucket of  
**25**  
coils



Ref. : 960447 **NEW**

## ANNEALED WIRE

Ø 1,5 mm

In bucket of 25 coils of about 250 g/18 m each.  
Enables to bind rebars together.  
Easy to store and carry.



## CUTTING NIPPERS

Forged tool made of chromium-vanadium (CrV).  
55-61 HRC jaws.  
42-48 HRC arms.  
Induction hardened jaws for greater performance.  
Handles with anti-slip PVC dipping.

Ref. : 040455  
**220 mm**

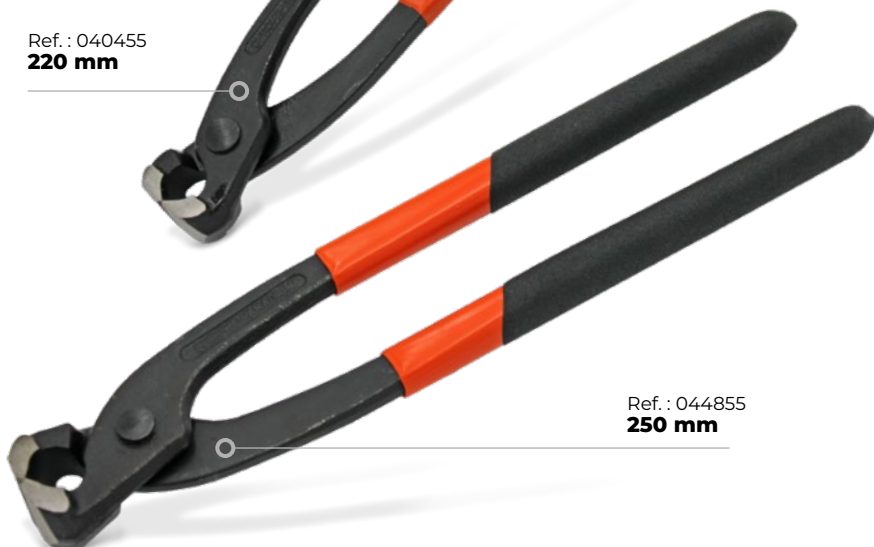
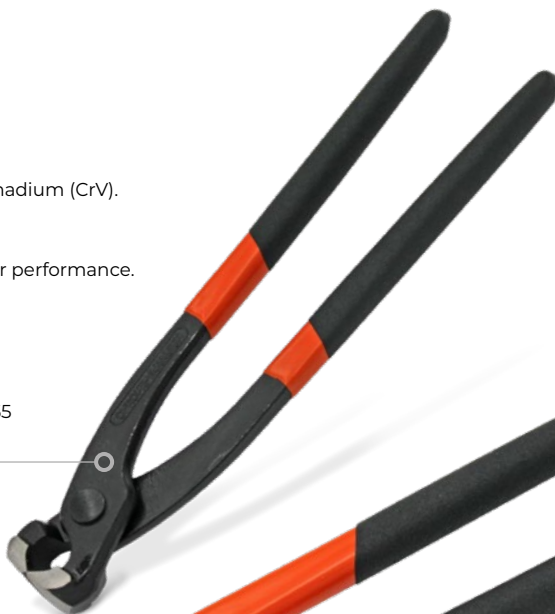

Ref. : 044855  
**250 mm**





Ref. : 283055 **NEW**

## GRADUATED MULTIFUNCTION BUCKET 33 l

Versatile = allows mixing, transporting, storing, distributing...

Integrated graduations (from 5 to 24 l) for dosing glue preparations, jointing, compound, mortars.

Convenient to use thanks to its metal handle and its 2 side handles.

Easy to clean.

Transparent lid sold separately (ref. 528300).

### SPECIFICATIONS

Material	PP
Upper outer diameter	380 mm
Upper inner diameter	357 mm
Lower outer diameter	322 mm
Height	370 mm
Volume to the top edge	33 l



Ref. : 528300

## TRANSPARENT LID

For 33 l graduated  
multifunction bucket

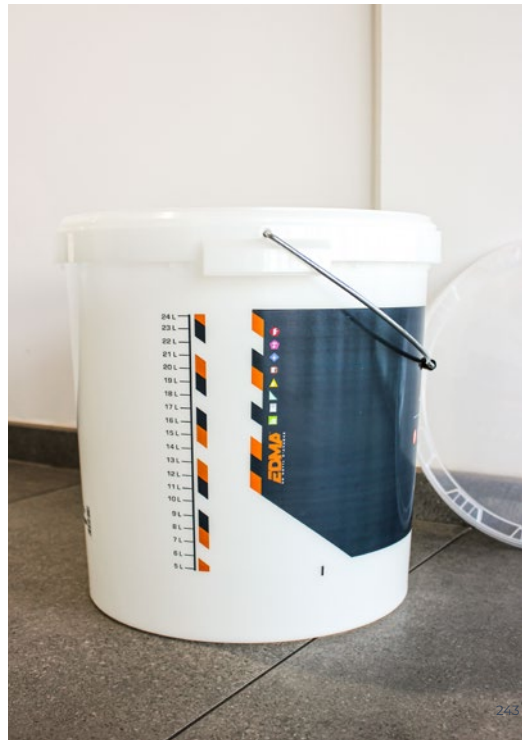



Ref. : 252155

## FLEXIBLE MIXING BUCKET

42 l

Ideal for glue preparation, jointing and transport of rubble.  
Made of polyethylene.  
Integrated graduations (liter and gallon).  
Equipped with 2 handles for easy transport.



Ref. : 096055

## CONCRETE SPREADER

*Ultra resistant.*

Allows to spread concrete easily thanks to its 500 mm width blade.  
Lifting hook (ø 10 mm) for rebar.  
29 mm conical shell for standard wooden handle.



Ref. : 290355

## 180 CM WOOD HANDLE

Ø 28,5 mm

For concrete spreader





Ref. : 266355

## FLOORING TROWEL

**500 mm**

Ideal for levelling and smoothing screeds.  
Steel blade 1,2 mm thick, wear-resistant.  
Polyamide frame reinforced with glass fiber = light and resistant.  
Ergonomic bi-material handle.



Ref. : 092855

**Medium grit 24**

Ref. : 092755

**Fine grit 36**

## ABRASIVE DISC

**Ø 125 mm**

Tungsten carbide universal abrasive disc for grinding machine.  
Heavy duty. Lasts up to 160 times longer than traditional abrasives.  
Polishing, deburring, surface finishing.  
For all types of materials, such as : steel, wood, cement, concrete, plaster, PVC, mild stone and rust.



## TILE LIFTER

Quick adjustment system.

Ideal to easily carry tiles.

Centered handle whatever the width of tile to carry.

ADJUSTABLE FROM	280 TO 665 MM	280 TO 800 MM
Ref.	269055	369055
Max. carried load*	35 kg	50 kg

\*Test performed by  on a 40 cm x 40 cm tile.



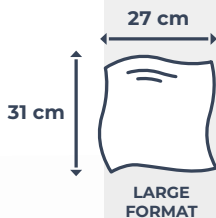

Program listed  
A1-A8-E4  
(Registration  
#147279).

Ref : 260655

## HAND AND SURFACE CLEANING WIPE

**x 90 pcs**

### **No rinsing, drying or residue.**

Safe for the epidermis, the wipe has a strong cleaning and detergent power.

Effective on hands as well as on smooth, non-porous surfaces such as worktops, tools, machines, computers, copiers/fax, whiteboards, car interiors, wheel rims.

Removes ordinary dirt as well as hard greases, fresh paints, adhesives, oils, lubricants, sludge, inks, waxes, bitumen, tar and other stubborn stains such as coal, graphite and grass marks.

**Composition :** vegetable solvents combined with an abrasive towel, which does not scratch.

Classified in cosmetic products.

# LANDSCAPER RANGE

## EASY USE, GARDEN HARMONY

EDMA's range of specific tools for landscaper is designed to give users a real time and effort saving on daily work.

Find out the entire range of must-have specific tools for installing wire mesh and gabion structures.









Ref. : 283055 **NEW**

## GRADUATED MULTIFUNCTION BUCKET 33 l

Versatile = allows mixing, transporting, storing, distributing...

Integrated graduations (from 5 to 24 l) for dosing glue preparations, jointing, compound, mortars.

Convenient to use thanks to its metal handle and its 2 side handles.

Easy to clean.

Transparent lid sold separately (ref. 528300).

### SPECIFICATIONS

Material	PP
Upper outer diameter	380 mm
Upper inner diameter	357 mm
Lower outer diameter	322 mm
Height	370 mm
Volume to the top edge	33 l

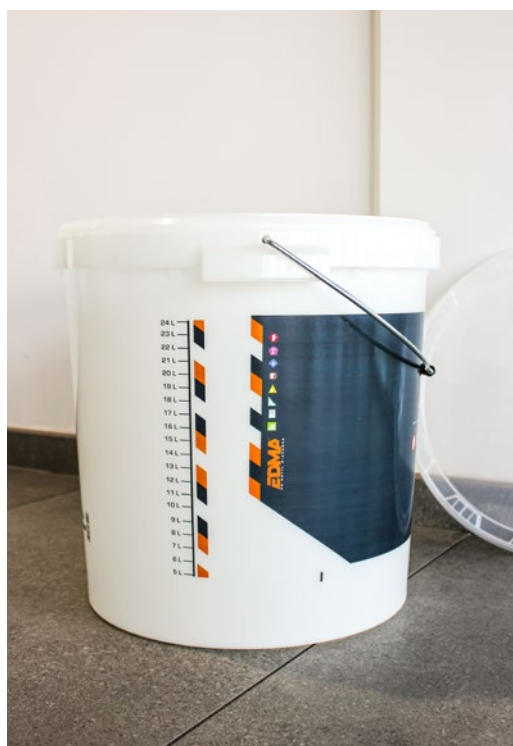



**150 x 45  
x 25 mm**



**90 x 45  
x 15 mm**



**80 x 30  
x 10 mm**

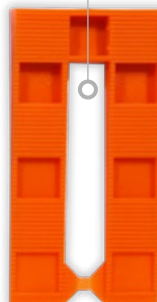

**80 x 40  
x 8 mm**

The split design allows the wedge to be positioned over a screw without falling to the ground.

## WEDGE

To level floorings or wooden decks.  
Fast and efficient level set up.  
Made of polyethylene.



BY COLOR	YELLOW	BROWN	GREEN	ORANGE	ASSORTMENT
In carton box / 100 pcs (Ref.)	--	188555	--	--	--
In storage box / 245 pcs (Ref.)	--	--	--	--	188455 60 orange / 70 green / 75 brown / 40 yellow
In bag (Ref. / Qty)	189355	189255	189055	189155	--
	x 6 pcs	x 16 pcs	x 30 pcs	x 30 pcs	



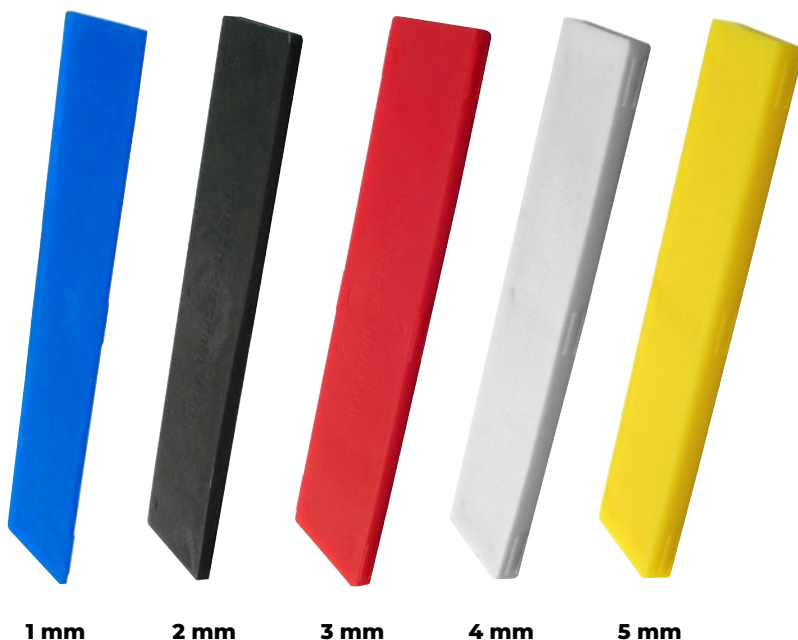

## FLAT SHIM

**Dimensions : 100 x 24 mm**

To level tiles floors, parquet, laminate flooring, panellings, wooden decks, stone decks, masonry works...  
Fast and efficient level set up.  
Made of polyethylene.

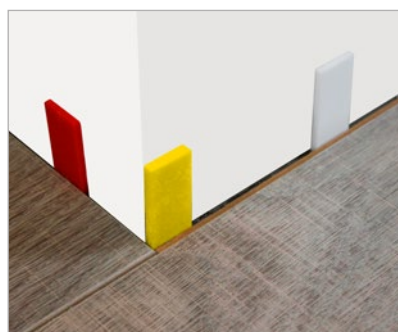

BY COLOR	BLUE	BLACK	RED	WHITE	YELLOW	ASSORTMENT
In carton box / 1000 pcs (Ref.)	186155	186255	186355	186455	186555	186055 200 shims of each thickness
In storage box / 400 pcs (Ref.)	--	--	--	--	--	188955 80 shims of each thickness
In bag / 50 pcs (Ref.)	--	--	--	--	--	188155 10 shims of each thickness

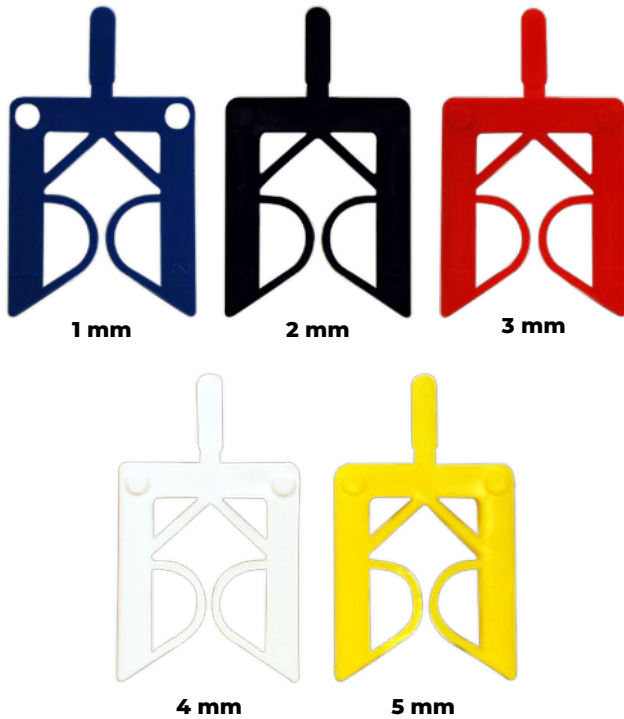

## HANGER SHIM

**Dimensions : 33 x 40 mm**

For windows and doors installation.  
Fast and efficient level set up.  
Made of polyethylene.



BY COLOR	BLUE	BLACK	RED	WHITE	YELLOW	ASSORTMENT
In carton box / 1000 pcs (Ref.)	185155	185255	185355	185455	185555	185055 200 shims of each thickness
In storage box / 500 pcs (Ref.)	--	--	--	--	--	188255 100 shims of each thickness
In bag / 50 pcs (Ref.)	--	--	--	--	--	188355 10 shims of each thickness



## PROTECTION PAD

**x 24 pcs**

To isolate the joist from the ground.  
Protects against moisture.  
Reduces noise transfer from trafficking.  
Stable and resistant.  
Must be used on compact and level floor.

### DIMENSIONS

Ref. : 187055	100 x 100 x 10 mm
Ref. : 187155	78 x 78 x 8 mm



Ref. : 085855

## SELF-ADHESIVE WATERPROOFING STRIP

**20 m x 80 mm**

Thickness: 1.4 mm.  
EPDM cellular foam.  
Protects the joists against water stagnation.  
Self-adhesive = easy to install.  
U.V. resistant.



## PROTECTIVE STRIP

Thickness : 1,9 mm.  
Protection against surface water.  
Sound insulation.  
Flexible waterproofing membrane made of a polyester reinforcement coated with elastomer bitumen.  
Durability : + 30 years.  
Fastening by staples or nails.

DIMENSIONS	<b>N</b>	20 M x 80 MM	<b>N</b>
	20 M x 60 MM		20 M x 100 MM
Ref.	086855	085355	086755
Recommended type of support	Joists, cleats and battens	Joists	Beams





Ref. : 031855 **PUNCHER**  
**HAMMER TACKER**

Recommended for fixing rain barrier, vapour barrier, under-roof radiant barrier films, sealing strips for timber-frame houses and protective strips for wooden joists.  
 Solidary magazine with quick and easy staple loading.  
 Magazine capacity : approx. 175 staples.  
 Large striking range.  
 Very good balance.  
 Ultra-comfortable bi-material handle.

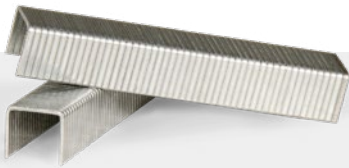

**STAPLE**

Galvanised staples.  
 Width: 10.6 mm.  
 Thickness: 1.2 mm.

HEIGHT	8 MM	10 MM	12 MM	14 MM
1000 pcs (Ref.)	232055	232155	232255	231955
5000 pcs (Ref.)	---	031955	---	---



Ref. : 086555 **PRESS DECK®**

## DECKING LATH STRAIGHTENER

Can be used with dense wood.  
 Decking straightener for all types of woods (even IPE, amongst the most dense woods in the world).  
 For decking planks between 90 and 180 mm width.  
 Also for vertical use.  
 Over 200 kg strength.  
 Straighten up to the last plank along a wall.  
 Pads to avoid damaging the decking.  
 Carrying case included.

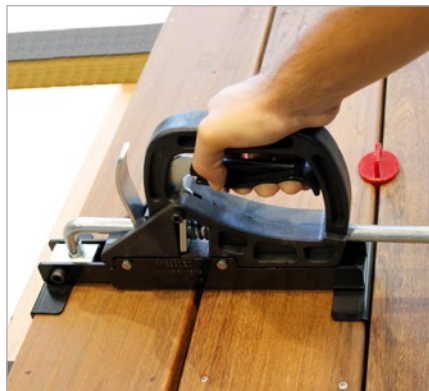

## GAP SPACER

With handle for easy removal.



3 mm



5 mm



7 mm

BY COLOR	BLUE	RED	YELLOW	ASSORTMENT
In storage box / 24 pcs (Ref.)	--	--	--	085755 8 spacers of each thickness
In bag / 10 pcs (Ref.)	085455	085555	085655	--

Ref. : 274855 **NEW**

## WOOD DECKING DRILLING KIT

Allows pre-drilling and countersinking of screw head housing in a single action.  
45° countersink with tungsten carbide tip = longer service life.  
Anti-friction metal stop, depth-adjustable.  
Suitable for hard and soft woods.

### Composed of :

- 1 pc HSS 3-point drill bit  $\varnothing$  4 x 55 mm
- 1 pc HSS 3-point drill bit  $\varnothing$  4 x 75 mm
- 1 pc  $\varnothing$  9.5 mm countersink with 6.35 mm quick-change hex shank
- 1 pc hex key



**NEW**

## PREMIUM MULTIPURPOSE MALLET

Multi-angle head with chamfered edges for easy positioning of flooring without damaging it.  
Avoids traces.  
Ergonomic, anti-slip handle.

PREMIUM MALLET	250 G	500 G
Ref.	261855	261955



Ref. : 074555 **PLURICOUP' ERGO**

## MULTI PURPOSE PLIERS WITH ANGLED BLADES

Light and *handy.*

42 mm stainless steel polished serrated blades.  
Ergonomic handles and easy-to-close latch.  
Angled blades for an optimum comfort while cutting.



Ref. : 042455 **PIC 7**

## MULTI-PURPOSE FARMING TOOL

Made of chromium-vanadium steel (CrV).

44-50 HRC.

Various applications : hammer, wire tensioner, staple remover, 2 wire cutters, splicer.

Handles with anti-slip PVC dipping.

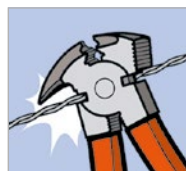
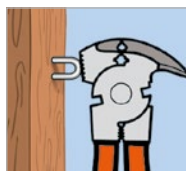
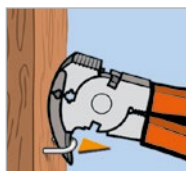

## CUTTING NIPPERS

Forged tool made of chromium-vanadium (CrV).  
 55-61 HRC jaws.  
 42-48 HRC arms.  
 Induction hardened jaws for greater performance.  
 Handles with anti-slip PVC dipping.



Ref. : 040455  
**220 mm**

Ref. : 044855  
**250 mm**



Ref. : 041855

## WIRE NET FENCING PACK

### COMPOSED OF

Ref. : 041155	<b>TOP GRAFER 20/22</b> Hog ring pliers	x 1 pc
Ref. : 043001	<b>OMEGA 20</b> Green PVC coated hog ring	x 1000 pcs
Ref. : 040455	Cutting nippers 220 mm	x 1 pc

For fast and easy installation of chain link fences.



Ref. : 042855 **MASTER GRAFER**

## HOG RING PLIERS FOR ROUND POSTS

Strong stainless steel jaws.  
Very easy to handle thanks to its sprung handles.

Jaw is specially designed to perfectly fix the welded mesh to the round metal post.

**Compatible with CL 29 staples.**



Ref. : 043855 **UNI-CLIP BECA**

## HOG RING PLIERS FOR «BECA» TYPE ROUND POSTS

Strong jaws.  
Very easy to handle thanks to its sprung handles.

**Compatible with CL 35 and CL 40 staples.**

**CL 35 staples Ø 3.5 mm to be used on round posts (BECA type).**

**CL 40 staples Ø 4 mm to be used on decorative gabion baskets.**



Ref. : 049255  
**HANDLE COILED SPRING**  
55 mm x 2 pcs.





Ref. : 041255 **BABY GRAFER 16/20**

## HAND HOG RING PLIERS

With built-in wire cutter up to 3 mm thickness.  
Stop guide for a stronger hold on the hog ring.

**Compatible with : OMEGA 16, 18, 20 and  
DELTA 18, 22.**



Ref. : 040655 **BABY GRAFER 30**

## HAND HOG RING PLIERS

Stop guide for a stronger hold on the hog ring.

**Compatible with : OMEGA 16, 18, 20 and  
DELTA 18, 22, 30.**

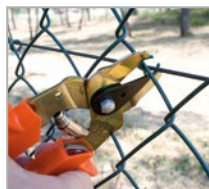

Ref. : 049255  
**HANDLE COILED SPRING**  
55 mm x 2 pcs.

## HAND HOG RING PLIERS WITH MAGAZINE

Light and *handy* tool.

50 staple magazine made of treated steel.  
Fast removal of magazine (less storage space).



Ref. : 040155

**TOP GRAFER 16**

Compatible with  
**OMEGA 16.**

Ref. : 040355

**TOP GRAFER 18**

Compatible with  
**OMEGA 18.**



Ref. : 049255  
**HANDLE COILED SPRING**  
55 mm x 2 pcs.

Ref. : 041155 **TOP GRAFER 20/22**

2 built-in wire cutters up to 3 mm thickness.  
**Compatible with DELTA 22 and OMEGA 20.**



Ref. : 040555

**TOP GRAFER 30**

**Compatible with  
DELTA 30.**



Ref. : 049255  
**HANDLE COILED SPRING**  
55 mm x 2 pcs.

## HAND HOG RING PLIERS WITH MAGAZINE

### Perpendicular fastening.

For wire mesh and rope netting.  
50 staple magazine.



Ref. : 040055

**JUNIOR**

Compatible with  
**OMEGA 16.**

**Max. fastening  $\varnothing$  :**  
2.1 + 2.2 mm (wire netting + tension wire).



Ref. : 049055  
**SPARE HANDLE  
SPRING**



Ref. : 041055

**MAJOR**

Compatible with  
**OMEGA 20.**

**Max. fastening  $\varnothing$  :**  
3.9 + 3.6 mm (wire netting + tension wire).



Ref. : 149155  
**SPARE HANDLE  
SPRING**

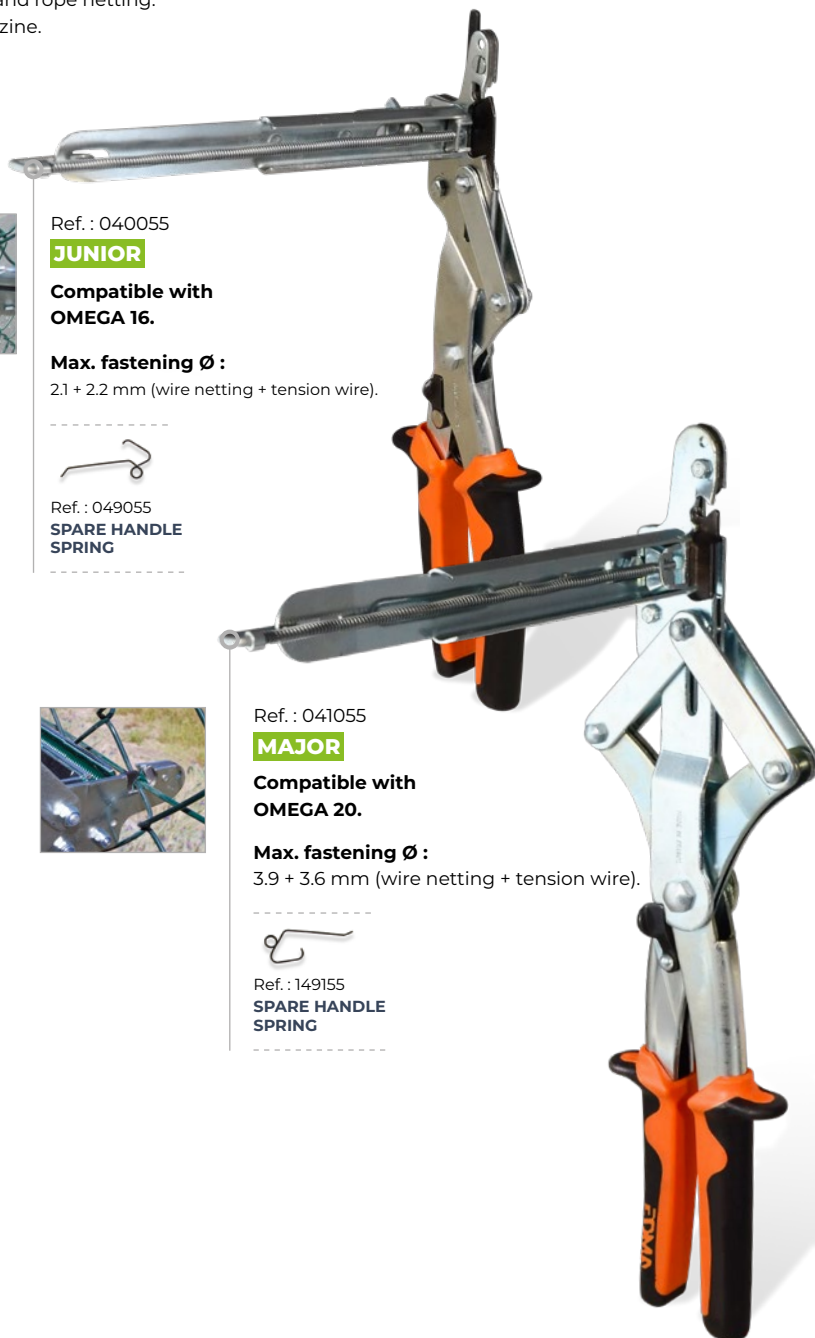



Ref. : 041455

**POWER GRAFER**

## **ADAPTABLE HOG RING PLIERS ON CORDLESS POWER DRILLS/SCREWDRIVERS**

Fits all types of cordless power drills (from 14.4 V).

High speed execution = time-saving.

50 staple magazine.

Magazine positioning for left and right-handed person.

**Compatible with OMEGA 20 and DELTA 22 staples.**



Ref. : 048455

## **FENCING TENSION CLAWS**

Set of 2 universal chain link fencing tensioners for T-section or round posts.

For a perfect and easy installation by one person.





Holds the netting in position while stapling it.







## OMEGA STAPLES

For hog ring pliers

	<b>OMEGA 16 STAPLE</b>	<b>250 PCS</b>	<b>1 250 PCS</b>	<b>2 500 PCS</b>
	<b>Wire Ø : 1,3 mm.</b>			
	<b>GALVANIZED</b> Wire resistance: 600 - 800 N/mm <sup>2</sup> .	Ref. : 041501	Ref. : 041901	Ref. : 041601
	<b>GALVANIZED GREEN PVC COATED</b> Wire resistance: 900 - 1100 N/mm <sup>2</sup> . RAL 6005.	Ref. 044501	Ref. 044201	Ref. : 044001
	<b>GALVANIZED DARK GREY PVC COATED</b> Wire resistance: 900 - 1100 N/mm <sup>2</sup> . RAL 7016.	Ref. : 040801	Ref. : 040901	--
	<b>AISI 316 STAINLESS STEEL</b> Wire resistance: 600 - 750 N/mm <sup>2</sup> .	--	Ref. : 044300	--
<b>COMPATIBLE PLIERS FOR OMEGA 16</b>	Ref. : 041255	BABY GRAFER 16/20		
	Ref. : 040655	BABY GRAFER 30		
	Ref. : 040155	TOP GRAFER 16		
	Ref. : 040055	JUNIOR		





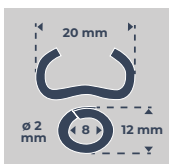

	<b>OMEGA 18 STAPLE</b>	<b>1 200 PCS</b>	<b>3 000 PCS</b>	
	<b>Wire Ø : 2 mm.</b>			
	<b>GALVANIZED</b> Wire resistance: 450 - 550 N/mm <sup>2</sup> .	Ref. : 900470	--	
	<b>GALVANIZED GREEN PVC COATED</b> Wire resistance: 450 - 600 N/mm <sup>2</sup> . RAL 6005.	--	Ref. : 900480	
<b>COMPATIBLE PLIERS FOR OMEGA 18</b>	Ref. : 041255	BABY GRAFER 16/20		
	Ref. : 040655	BABY GRAFER 30		
	Ref. : 040355	TOP GRAFER 18		





### OMEGA 20 STAPLE

Wire Ø : 2 mm.

	200 PCS	1 000 PCS
 <p><b>GALVANIZED</b> Wire resistance: 450 - 550 N/mm<sup>2</sup>.</p>	Ref. : 042501	Ref. : 042001
 <p><b>GALVANIZED GREEN PVC COATED</b> Wire resistance: 450 - 600 N/mm<sup>2</sup>. RAL 6005.</p>	Ref. : 043501	Ref. : 043001
 <p><b>GALVANIZED DARK GREY PVC COATED</b> Wire resistance: 450 - 600 N/mm<sup>2</sup>. RAL 7016.</p>	Ref. 042601	Ref. : 043201
 <p><b>GALVANIZED BLACK PVC COATED</b> Wire resistance: 450 - 600 N/mm<sup>2</sup>. RAL 9005.</p>	--	Ref. : 047201
 <p><b>GALVANIZED WHITE PVC COATED</b> Wire resistance: 450 - 600 N/mm<sup>2</sup>. RAL 9003.</p>	Ref. : 042900	--
 <p><b>ALUMINIUM</b> Wire resistance: 270 N/mm<sup>2</sup>.</p>	--	Ref. : 042101
 <p><b>AISI 316 STAINLESS STEEL</b> Wire resistance: 550 - 650 N/mm<sup>2</sup>.</p>	--	Ref. : 042301
<b>COMPATIBLE PLIERS FOR OMEGA 20</b>	Ref. : 041255	BABY GRAFER 16/20
	Ref. : 040655	BABY GRAFER 30
	Ref. : 041155	TOP GRAFER 20/22
	Ref. : 041055	MAJOR
	Ref. : 041455	POWER GRAFER

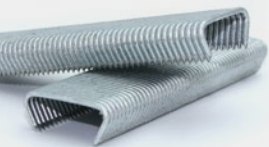

## DELTA STAPLES

For hog ring pliers

	<p><b>DELTA 18 STAPLE</b> Wire Ø : 1,6 mm.</p>	<p><b>3 360 PCS</b></p>	
	<p><b>COOPER</b> Wire resistance: 850 - 950 N/mm<sup>2</sup>.</p>	<p>Ref. 900466</p>	
<p><b>COMPATIBLE PLIERS FOR DELTA 18</b></p>		<p>Ref. : 041255</p>	<p>BABY GRAFER 16/20</p>
		<p>Ref. : 040655</p>	<p>BABY GRAFER 30</p>
	<p><b>DELTA 22 STAPLE</b> Wire Ø : 2 mm.</p>	<p><b>1 000 PCS</b></p>	
	<p><b>GALVANIZED</b> Wire resistance: 450 - 550 N/mm<sup>2</sup>.</p>	<p>Ref. : 900460</p>	
	<p><b>AISI 316 STAINLESS STEEL</b> Wire resistance: 550 - 650 N/mm<sup>2</sup>.</p>	<p>Ref. : 900461</p>	
	<p><b>GALVANIZED GREEN PVC COATED</b> Wire resistance: 450 - 600 N/mm<sup>2</sup>. RAL 6005.</p>	<p>Ref. : 900463</p>	
<p><b>COMPATIBLE PLIERS FOR DELTA 22</b></p>		<p>Ref. : 041255</p>	<p>BABY GRAFER 16/20</p>
		<p>Ref. : 040655</p>	<p>BABY GRAFER 30</p>
		<p>Ref. : 041155</p>	<p>TOP GRAFER 20/22</p>
		<p>Ref. : 041455</p>	<p>POWER GRAFER</p>
	<p><b>DELTA 30 STAPLE</b> Wire Ø : 2 mm.</p>	<p><b>500 PCS</b></p>	<p><b>2 500 PCS</b></p>
	<p><b>GALVANIZED</b> Wire resistance: 450 - 550 N/mm<sup>2</sup>.</p>	<p>Ref. 047101</p>	<p>Ref. 046500</p>
<p><b>COMPATIBLE PLIERS FOR DELTA 30</b></p>		<p>Ref. : 040655</p>	<p>BABY GRAFER 30</p>
		<p>Ref. : 040555</p>	<p>TOP GRAFER 30</p>

## CL STAPLES

For hog ring pliers



	<p><b>CL 29 STAPLE</b>  <b>Wire Ø : 2,9 mm.</b>            In bulk.</p>	<p><b>100 PCS</b></p>	<p><b>500 PCS</b></p>	<p><b>1 000 PCS</b></p>
	<p><b>AISI 304 STAINLESS STEEL</b>            Wire resistance: 650 - 800 N/mm<sup>2</sup>.</p>	<p>Ref. : 046801</p>	<p>Ref. : 146800</p>	<p>Ref. : 047300</p>
	<p><b>GALVANIZED</b>            Wire resistance: 450 - 550 N/mm<sup>2</sup>.</p>	<p>Ref. : 046901</p>	<p>--</p>	<p>Ref. : 047400</p>
<p><b>COMPATIBLE PLIERS FOR CL 29</b></p>		<p>Ref. : 042855</p>	<p>MASTER GRAFER</p>	
	<p><b>CL 35 STAPLE</b>  <b>Wire Ø : 3,5 mm.</b>            In bulk.</p>	<p><b>500 PCS</b></p>		
	<p><b>AISI 304 STAINLESS STEEL</b>            Wire resistance: 719 N/mm<sup>2</sup>.</p>	<p>Ref. 043700</p>		
<p><b>COMPATIBLE PLIERS FOR CL 35</b></p>		<p>Ref. : 043855</p>	<p>UNI-CLIP BECA</p>	
	<p><b>CL 40 STAPLE</b>  <b>Wire Ø : 4 mm.</b> <i>Special for gabion</i>            In bulk.</p>	<p><b>1 000 PCS</b></p>		
	<p><b>ALUZINC</b>            Wire resistance: 486 - 509 N/mm<sup>2</sup>.            Special for decoration gabion cages.</p>	<p>Ref. 140001</p>		
<p><b>COMPATIBLE PLIERS FOR CL 40</b></p>		<p>Ref. : 043855</p>	<p>UNI-CLIP BECA</p>	



Ref. : 045555 **TORNADO**  
**AUTOMATIC BINDER  
 FOR LOOP TIE WIRE**

Allows to tie rebars, fencings, gravel bags.  
 Soft hand grip.



Ref. : 960452  
**Galvanized**  
**Ø 1 mm x 120 mm**  
 x 1000 pcs.



Ref. : 960491  
**Green plastified coated**  
**Ø 1,4 mm x 200 mm**  
 x 1000 pcs.

**LOOP TIE WIRE**

Allows to fasten elements together.  
 To use with an automatic binder.

**For different kinds of fastening :** rebar, fencing,  
 gravel bags.

Approximative quantity per coil.

Ref. : 040755

**DRESS FIL**

## WIRE TENSIONER FOR NETTING AND WELDED NETS

Guarantee of a perfect installation by ensuring rigidity on the fence.  
Effective stiffening by successive pinching of the horizontal wires.  
Creates uniform fencing.



Ref. : 047755

## HAND STAPLER FOR CONCERTINA RING INSTALLATION

Pliers to fix concertina razor wire and barbed wire.  
One hand operation.  
For galvanised (ref. 046601) concertina rings.

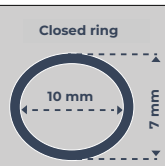

### RING FOR CONCERTINA

1 000 PCS

#### GALVANIZED

In bulk.  
Galvanized treatment.

Ref. 046601



Ref. : 049855 **TURBO 24**  
**PNEUMATIC GUN FOR CL 24**  
**STAPLE INSTALLATION**

**SPECIFICATIONS**

Working pressure	5-8 bars
Magazine capacity	around 100 CL 24 staples

**Applications :**

- Swimming pool formwork.
- Industrial fastening.



	<p><b>CL 24 STAPLE</b>  <b>Wire Ø : 1,8 mm.</b></p>	<p><b>10 000 PCS</b></p>
	<p><b>GALVANIZED</b>          Wire resistance: 650 - 750 N/mm<sup>2</sup>.          Galvanized treatment.</p>	<p>Ref. 190000</p>





Ref. : 049555

**TURBO 50 PREMIUM**

## PNEUMATIC GUN FOR CL 50 GABION STAPLE INSTALLATION

**Special for gabion installations.**  
Quick loading system for staples.

### SPECIFICATIONS

Working pressure	5-7 bars
Magazine capacity	120 CL 50 (45 x 24 x 3 mm) staples
Fastening speed	40 staples per minute

**Applications :** erosion protection, retaining walls, soil reinforcement, road construction, coastal protection, civil engineering, etc...  
Comes in heavy duty, ergonomic plastic case.  
Ultra-rugged machine for an intensive use.  
Magazine protector included.



Ref. : 249818  
**UPPER JAW**



Ref. : 249826  
**LOWER JAW**

### CL 50 STAPLE *Special for gabion*

Wire Ø : 3 mm.

**1 600 PCS**



#### ALUZINC HIGH TENSILE

Wire resistance: 1750 - 1950 N/mm<sup>2</sup>.  
Made of 95% zinc + 5% aluminium.

Ref. 150000

#### AISI 304 STAINLESS STEEL

Wire resistance: 1500 - 1700 N/mm<sup>2</sup>  
AISI 304 stainless steel.

Ref. 160000



Ref. : 046455

## HAND STAPLER WITH MAGAZINE FOR CL 50 GABION STAPLE INSTALLATION

Quick to use.  
Easy loading of the staples.  
Locking security.

### SPECIFICATIONS

Magazine capacity	+/- 50 CL 50 (45 x 24 x 3 mm) staples
-------------------	---------------------------------------

**Applications :** erosion protection, retaining walls, soil reinforcement, road construction, coastal protection, civil engineering, etc...



**CL 50 STAPLE** *Special for gabion*  
Wire Ø : 3 mm.

**1 600 PCS**



#### ALUZINC HIGH TENSILE

Wire resistance: 1750 - 1950 N/mm<sup>2</sup>.  
Made of 95% zinc + 5% aluminium.

Ref. 150000

#### AISI 304 STAINLESS STEEL

Wire resistance: 1500 - 1700 N/mm<sup>2</sup>  
AISI 304 stainless steel.

Ref. 160000

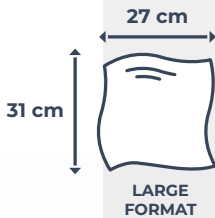

Ref : 260655

## HAND AND SURFACE CLEANING WIPE

**x 90 pcs**

### **No rinsing, drying or residue.**

Safe for the epidermis, the wipe has a strong cleaning and detergent power.

Effective on hands as well as on smooth, non-porous surfaces such as worktops, tools, machines, computers, copiers/fax, whiteboards, car interiors, wheel rims.

Removes ordinary dirt as well as hard greases, fresh paints, adhesives, oils, lubricants, sludge, inks, waxes, bitumen, tar and other stubborn stains such as coal, graphite and grass marks.

**Composition :** vegetable solvents combined with an abrasive towel, which does not scratch.

Classified in cosmetic products.

# ALPHABETIC INDEX

## A

ABRASIVE BLOCK - 150 x 50 x 25 mm	112		
ABRASIVE DISC - 125 mm - Medium grit 24 / Fine grit 36	245		
Abrasive hand sander - <b>EASY LOCK SANDER</b>	76		
Abrasive hand sander adaptable to a telescopic pole <b>EASY LOCK TELESCOPIC SANDER</b>	76		
ABRASIVE MESH SANDING SHEET 290 x 100 MM - x 10 pcs Grit 80 / Grit 120 / Grit 240	76		
ABRASIVE SANDER SPECIAL FOR E.T.I.C.S. - 380 x 160 mm	173		
ACCESS PANEL TO BE TILED - 30 x 30 cm / 40 x 40 cm	118		
Adaptable hog ring pliers on cordless power drills/screwdrivers <b>POWER GRAFER</b>	265		
Adaptable nibbler shears on cordless power drills/screwdrivers <b>NIBBLEX® UNIVERSAL</b>	202		
Adaptable shears on cordless power drills/screwdrivers <b>TURBOSHEAR</b>	201		
ADAPTOR FOR INSULACUT SAW FOR BIO-BASED INSULATION CUTTING TABLE	153		
ADAPTOR FOR VACUUM CLEANER FOR WOOLCUT	155		
ADAPTOR FOR WOOLCUT, BOSCH GFZ 16-35 AC, FESTOOL ISC 240, DEWALT DWE 397/DSC 397 SAWS FOR BIO-BASED INSULATION CUTTING TABLE	153		
ADJUSTABLE ANGLE SQUARE	43		
ADJUSTABLE BLIND HOLE CUTTER Ø 30 TO 150 MM Kit for hot knife	161		
<b>ALPHACUT</b> - Guillotine to cut fiber cement siding	222		
<b>ALU LINE</b> - 30 m aluminium chalk line reel	27	235	
Aluminium chalk line reel - 30 m - <b>ALU LINE</b>	27	235	
ANGULAR ABRASIVE SPONGE - Grit 60	76		
ANGULAR TINMAN'S MALLET	213		
ANNEALED LOOP TIE WIRE - Ø 1,1 x 100 mm - x 1000 pcs	241		
ANNEALED LOOP TIE WIRE - Ø 1,1 x 120 mm x 1000 pcs / x 2500 pcs / x 5000 pcs	241		
ANNEALED LOOP TIE WIRE - Ø 1,1 x 140 mm x 1000 pcs / x 2500 pcs / x 5000 pcs	241		
ANNEALED LOOP TIE WIRE - Ø 1,1 x 160 mm x 1000 pcs / x 2500 pcs	241		
ANNEALED LOOP TIE WIRE - Ø 1,1 x 180 mm - x 1000 pcs	241		
ANNEALED LOOP TIE WIRE - Ø 1,1 x 200 mm - x 1000 pcs	241		
ANNEALED WIRE Ø 1.5 MM	242		
<b>APOLLO</b> - Forged aviation snip - Right cut / Left cut	20	197	
Automatic binder for loop tie wire - <b>TORNADO</b>	241	270	
Automatic section setting pliers for all types of studs and tracks, fits on cordless power drills/screwdrivers <b>POWER PROFIL</b>	34		

## B

<b>BABY GRAFER 16/20</b> - Hand hog ring pliers	261		
<b>BABY GRAFER 30</b> - Hand hog ring pliers	261		
<b>BABY-FIX® BRICO</b> - Expansion tool for all metal anchors	78		
<b>BABY-FIX® JUNIOR</b> - Expansion tool for all metal anchors For <b>EDMATILE</b> and <b>EDMATILE XXL</b>	78		
BAG OF 25 BRUSHES - For roofer's holder	214		
BALL BEARING CUTTING WHEEL - Ø 22 x Ø 6 x 2 mm For <b>EDMATILE</b> and <b>EDMATILE XXL</b>	105	106	
BATTEN GAUGE - For wooden batten positioning	187		
BENDING STICK	212		
BEVEL	194		
BLADE FOR <b>MAT 2</b> AND <b>MAT COUP 2</b> - 55 mm	191		
BLADE FOR <b>MAT</b> AND <b>MAT COUP</b> - 35 mm	191		
BLADE FOR <b>NIBBLER SHEARS NR1</b>	200		
BLADE FOR <b>SUPERCROUP</b>	200		
BLADE FOR <b>SUPERCROUP NR3</b>	201		
BLADE HOLDER FOR <b>WOOLCUT</b> - 240 MM / 350 MM	155		
BLADE SET FOR <b>CANALCUT</b> - 40, 60, 80, and 100 mm	36	173	
BLIND HOLE CUTTER FOR HOT KNIFE - Ø 70 mm	161		
<b>BLOC PARKET</b> Tapping block for hardwood and laminate flooring	144		
<b>BLOCPLAC</b> - Board holder	39		
BLUE MARKING CHALK - 200 g / 400 g / 1000 g / 3500 g	27	185	235
Board carrier handles - <b>DUOPLAC</b>	39		
Board holder - <b>BLOCPLAC</b>	39		
Board lever with steel stirrup - <b>FOOTPLAC</b>	39	147	
BOSSING STICK	212		
BOX OF 10 DIAMOND CORE DRILLS Ø 6, 8, 10, 12, 28, 35, 40, 45, 65, 68 mm	111		
BOX OF 8 DIAMOND DRILL BITS Ø 6, 8, 10, 12, 28, 35, 43, 68 mm	111		
BRACKET	194		
BRASS PRESSURE ROLLER - 6 mm width	219		
BUCKET SCOOP KNIFE	54	89	

## C

<b>CAMELEON 130</b> - Mitre guillotine	146		
<b>CANALCUT</b> - Precision insulation cutter	36	173	
CARPENTER PENCIL - x 12 pcs	185		
CARRYING CASE SIZE - M / L / XL	105		
CARTON OF 20 WIRE COILS FOR <b>EDMATYER</b>	239		

Chalk line reel special for roofers - 30 m - <b>ROOF LINE</b>	184			
Chalk line reel with large handle - 50 m - <b>MAX LINE</b>	27	185	235	
Chamfering plane for plasterboard - <b>RAP-PLAC VERSATILE</b>	43			
CHARGER FOR LITHIUM BATTERY 14.4 V - 1.5 AH	159			
CHARGER FOR LITHIUM BATTERY 18 V	155	157	163	168
	171	233		
CHARGER FOR LITHIUM BATTERY 36 V - 2 AH	165	167	169	172
	230	231		
CL 24 STAPLE - Galvanized - x 10000 pcs	240	272		
CL 29 STAPLE - AISI 304 stainless steel x 100 pcs / x 500 pcs / x 1000 pcs	269			
CL 29 STAPLE - Galvanized A - x 100 pcs / x 1000 pcs	269			
CL 35 STAPLE - AISI 304 stainless steel - x 500 pcs	269			
CL 40 STAPLE - Aluzinc - x 1000 pcs	269			
CL 50 STAPLE - AISI 304 stainless steel - x 1600 pcs	273	274		
CL 50 STAPLE - Aluzinc high tensile - x 1600 pcs	273	274		
Cladding supports - <b>CLIN FIX®</b>	221			
Clamping head - <b>EDMALEVEL SCREW</b>	125			
CLEANING BRUSH + SQUEEGEE - 42 cm	130			
CLEANING FLOAT - Self-gripping	129			
<b>CLIN FIX®</b> - Cladding supports	221			
CLINCHING PLIERS - Bent of 45° - 22 mm / 60 mm / 80 mm	208			
CLINCHING PLIERS - Bent of 90° - 60 mm	209			
CLINCHING PLIERS - Straight 22 mm / 60 mm / 80 mm / 100 mm	208			
COLOR LEAD FOR EDMARKER - x 6 pcs	185	234		
COMPASS - 250 mm	195			
COMPLETE MAGNETIC CUTTING TROLLEY - For <b>EDMATILE</b>	105			
Complete set for installing laminate flooring - <b>SET TAK-TIK</b>	143			
CONCRETE SPREADER - Ultra resistant	244			
Construction pencil with retractable lead - <b>EDMARKER</b>	185	234		
Cordless electric saw for biobased and mineral insulation materials - <b>WOOLCUT</b>	154	155		
CORDLESS ELECTRIC SUCTION CUP	117			
Cordless hot wire cutter for polystyrene - <b>STYROGUN</b>	170	171	232	233
Cordless hot wire cutter for polystyrene <b>STYROGUN</b> WITHOUT BATTERY OR CHARGER	170	171	232	233
CORDLESS HOT WIRE CUTTING BOW - For polystyrene	172	231		
Cordless LED surface inspection light - <b>EDMALIGHT</b>	74	84		
Cordless rebar tyer - 24 mm - <b>EDMATYER</b>	238	239		
Cordless rebar tyer - 24 mm - <b>EDMATYER</b> WITHOUT BATTERY OR CHARGER	238	239		
Cordless rebar tyer - 40 mm - <b>EDMATYER XL</b>	238	239		
Cordless rebar tyer - 40 mm - <b>EDMATYER XL</b> WITHOUT BATTERY OR CHARGER	238	239		
CORE DRILL Ø 6 mm / Ø 10 mm / Ø 12 mm / Ø 28 mm / Ø 35 mm / Ø 40 mm / Ø 45 mm / Ø 65 mm / Ø 68 mm / Ø 100 mm / Ø 120 mm	110			
CORNER COATING KNIFE	66	93		
<b>CORNER FIX</b> - Hand tool for fixing corner beads	48			
<b>COVERABSORB 10</b> - 10 m protection and packing cover	49			
<b>COVERABSORB 25</b> - 25 m protection and packing cover	49			
<b>COVERPROTECT</b> - Anti-slip and reusable protective cover	49			
<b>COVERUP</b> - Anti-slip and breathable protective cover	49			
<b>CROCOPLAC II</b> - jab saw with teeth on both sides 150 mm / 250 mm	42			
Cross spacer - x 200 pcs - <b>EDMALEVEL SCREW</b> 1 mm / 2 mm / 3 mm	125			
CUTTED SPONGE FLOAT - 280 x 140 mm	128			
CUTTING GUIDE FOR HOT KNIFE - 210 mm	161			
CUTTING GUIDE WITH ADJUSTABLE ANGLE FOR <b>WOOLCUT</b>	155			
CUTTING GUIDE WITH WHEELS FOR <b>WOOLCUT</b>	155			

CUTTING NIPPERS - 220 mm / 250 mm	242	259		
Cutting system for large tiles - <b>EDMATILE XXL</b>	106			
CUTTING TABLE FOR BIO-BASED INSULATION MATERIALS	152	153		
CUTTING UNIT FOR <b>SUPERCOP</b>	200			

## D

DEAD BLOW SOFT FACED HAMMER	213			
DECHAUSS' TOUT - Telescopic wooden batten remover	181			
Decking lath straightener - <b>PRESS DECK®</b>	256			
DECLIMETER	187			
DELTA 18 STAPLE - Cooper - x 3360 pcs	268			
DELTA 22 STAPLE - AISI 316 stainless steel - x 1000 pcs	268			
DELTA 22 STAPLE - Galvanized A - x 1000 pcs	268			
DELTA 22 STAPLE - Galvanized green PVC coated - x 1000 pcs	268			
DELTA 30 STAPLE - Galvanized A - x 500 pcs / x 2500 pcs	268			
DISK ROLLER WITH RETRACTABLE STOPPER Tool to make bends from 90° to 180° maximum	207			
DOUBLE BENDER 4 ROLLS Tool to make folds, counterfolds, raised areas on sheets	204			
DOUBLE BENDER 8 ROLLS Tool to make folds, counterfolds, raised areas on sheets	204			
DOUBLE BLADE FOR COMPRESSED INSULATION FOR <b>WOOLCUT</b> 240 MM / 350 MM	155			
DOUBLE BLADE FOR FLEXIBLE INSULATION FOR <b>WOOLCUT</b> 240 MM / 350 MM	155			
DOUBLE DISK ROLLER Tool to make bends from 90° to 180° maximum	207			
DOUBLE HOT WIRE CUTTING TABLE For polystyrene, especially for E.T.I.C.S. applications	162	163		
DOUBLE SEAMING IRON	214			
DOUBLE SUCTION CUP	116			
<b>DRESS FIL</b> - Wire tensioner for netting and welded nets	271			
DRILL BIT Ø 6 mm / Ø 8 mm / Ø 10 mm / Ø 12 mm / Ø 28 mm / Ø 35 mm / Ø 43 mm / Ø 68 mm / Ø 100 mm / Ø 120 mm	110			
DRILL GUIDE FOR DRILL BITS - Ø 6 to 84 mm	111	257		
DRILLING TEMPLATE FOR BOSCH SAW GFZ 16-35 AC FOR BIO-BASED INSULATION CUTTING TABLE	153			
DRILLING TEMPLATE FOR DEWALT SAWS DWE 397/DSC 397 FOR BIO-BASED INSULATION CUTTING TABLE	153			
DRILLING TEMPLATE FOR FESTOOL SAW ISC 240 FOR BIO-BASED INSULATION CUTTING TABLE	153			
DRYWALL BENCH	50			
DRYWALL SCORING SQUARE	40			
Drywall stripper - <b>PLAC &amp; ROLL</b>	43			
DRYWALL TAPE HOLDER	55			
Drywall taper with corner roller - <b>EDMAPLIC</b>	56	57		
DRYWALL UTILITY KNIFE - With 25 mm snap-off blades	41			
DRYWALLER STILTS	51			
DUAL CHARGER FOR LITHIUM BATTERY 14.4 V - 2 AH FOR <b>EDMATYER</b>	239			
DUAL CHARGER FOR LITHIUM BATTERY 18 V	155	157	163	168
	171	233		
DUAL HOLDER FOR LITHIUM BATTERY 18 V FOR DOUBLE HOT WIRE CUTTING TABLE	163			
DUAL-SYSTEM KNIFE	41			
<b>DUO PROFIL</b> - Section setting pliers for back-to-back studs	33			
<b>DUOPLAC</b> - Board carrier handles	39			
<b>DUOTOP</b> Guillotine for 48 mm metal studs and tracks, M6 threaded rod	25			
<b>DUPLIC FORM</b> - 250 mm contour gauge	108	137		

# E

<b>EASY LOCK SANDER</b> - Abrasive hand sander	76			
<b>EASY LOCK TELESCOPIC SANDER</b> Abrasive hand sander adaptable to a telescopic pole	76			
<b>EASY RAP</b> - Mini plane for plasterboard	40			
EAVES CLOSING JAWS	211			
EAVES EDGER 105 TK	211			
<b>EDGE ROLLER</b> - 25 mm Tool to make bends from 90° to 180° maximum	206			
<b>EDMABLADE</b> - Flexible smoothing blade 15 cm / 25 cm / 35 cm / 45 cm / 60 cm / 80 cm / 100 cm	68	69	94	95
<b>EDMABLADE</b> - Flexible smoothing blade 60 cm / 80 cm / 100 cm	175			
<b>EDMABLADE</b> - Stiff smoothing blade 15 cm / 25 cm / 35 cm / 45 cm / 60 cm / 80 cm / 100 cm	68	69	94	95
<b>EDMABLADE</b> - Stiff smoothing blade 60 cm / 80 cm / 100 cm	175			
<b>EDMABLADE HANDLE</b>	73	98		
<b>EDMABOX</b> - Stackable storage box	16			
<b>EDMACLEAN</b> - 24 l tile joint kit + accessories	126			
<b>EDMAFOAM</b> - Hot knife with air-cooling system Hot knife + 3 blades set	160			
<b>EDMAFOAM</b> - Hot knife with air-cooling system - Starting kit	160			
<b>EDMAGNETIK</b> - Magnetic system for making inspection hatches	118			
<b>EDMALEVEL SCREW</b> - Clamping head	125			
<b>EDMALEVEL SCREW</b> - Cross spacer - x 200 pcs 1 mm / 2 mm / 3 mm	125			
<b>EDMALEVEL SCREW</b> - Linear spacer - x 200 pcs 1 mm / 2 mm / 3 mm	125			
<b>EDMALEVEL SCREW</b> - Self-levelling system starting kit 1 mm / 2 mm	124			
<b>EDMALEVEL SCREW</b> - T spacer - x 200 pcs 1 mm / 2 mm / 3 mm	125			
<b>EDMALEVEL SELF-LEVELLING SYSTEM</b> - Adjusting pliers	123			
<b>EDMALEVEL SELF-LEVELLING SYSTEM</b> - Starting kit 100 pcs 1.5 mm / 2 mm	122			
<b>EDMALEVEL SELF-LEVELLING SYSTEM</b> - Tile spacer - 1 mm x 500 pcs	123			
<b>EDMALEVEL SELF-LEVELLING SYSTEM</b> - Tile spacer - 1.5 mm 250 pcs / x 500 pcs / x 1000 pcs	123			
<b>EDMALEVEL SELF-LEVELLING SYSTEM</b> - Tile spacer - 2 mm 250 pcs / x 500 pcs / x 1000 pcs	123			
<b>EDMALEVEL SELF-LEVELLING SYSTEM</b> - Tile spacer - 3 mm x 500 pcs	123			
<b>EDMALEVEL SELF-LEVELLING SYSTEM</b> - Tile wedge - x 250 pcs	123			
<b>EDMALEVEL SELF-LEVELLING SYSTEM</b> - XL tile spacer 1.5 mm - x 250 pcs	123			
<b>EDMALEVEL SELF-LEVELLING SYSTEM</b> - XL tile spacer 2 mm - x 250 pcs	123			
<b>EDMALIGHT</b> - Cordless LED surface inspection light	74	84		
<b>EDMALIGHT COMPATIBLE TELESCOPIC TRIPOD</b>	75	85		
<b>EDMAPLAC 450</b> - Rack and pinion panel lifter	44	45	46	
<b>EDMAPLIC</b> - Drywall taper with corner roller	56	57		
<b>EDMARKER</b> - Construction pencil with retractable lead	185	234		
<b>EDMATILE 650</b> - Monorail tile cutter	104			
<b>EDMATILE 650 IN CARRYING CASE</b> - Monorail tile cutter	104			
<b>EDMATILE 950</b> - Monorail tile cutter	104			
<b>EDMATILE 950 IN CARRYING CASE</b> - Monorail tile cutter	104			
<b>EDMATILE 1350</b> - Monorail tile cutter	104			
<b>EDMATILE 1350 IN CARRYING CASE</b> - Monorail tile cutter	104			
<b>EDMATILE XXL</b> - Cutting system for large tiles	106			
<b>EDMATYER</b> - 24 mm cordless rebar tyer	238	239		
<b>EDMATYER WITHOUT BATTERY OR CHARGER</b> 24 mm cordless rebar tyer	238	239		

<b>EDMATYER XL</b> - 40 mm cordless rebar tyer	238	239		
<b>EDMATYER XL WITHOUT BATTERY OR CHARGER</b> 40 mm cordless rebar tyer	238	239		
ERGONOMIC JOINT KNIFE - 25 cm / 35 cm / 60 cm	65			
ERGONOMIC PRESSURE ROLLER - 45 mm width	219			
<b>ERGOTOP®</b> Section setting pliers for all types of studs and tracks	31			
Expansion gun for all metal anchors - <b>SUPER-FIX®</b>	79			
Expansion gun for all metal anchors - <b>SUPRA-FIX®</b>	79			
Expansion tool for all metal anchors - <b>BABY-FIX® BRICO</b>	78			
Expansion tool for all metal anchors - <b>BABY-FIX® JUNIOR</b>	78			
Expansion tool for all metal anchors - <b>FIX</b>	78			
EXTENSION 120 CM - For hot knife	161			

# F

F530 ADAPTOR FOR <b>STUD CUTTER</b> AND <b>DUOTOP</b>	22	25		
<b>FAST LINE</b> - 30 m fast rewinding chalk line reel	27	235		
Fast rewinding chalk line reel - 30 m - <b>FAST LINE</b>	27	235		
FENCING TENSION CLAWS	265			
FIGURE HOLE FORGED SHEARS - 250 mm - Right cut / Left cut	199			
FIX - Expansion tool for all metal anchors	78			
<b>FLAT RASP FOR EASY RAP</b>	40			
<b>FLAT RASP FOR VARIO RAP</b>	40			
<b>FLAT SHIM</b> - 100 x 24 mm - Assortment x 50 pcs / x 400 pcs / x 1000 pcs	142	252		
<b>FLAT SHIM</b> - x 1000 pcs 100 x 24 x 1 mm / 2 mm / 3 mm / 4 mm / 5 mm	142	252		
<b>FLEXIBLE BLADE JOINT KNIFE</b> 2,5 cm / 4 cm / 6 cm / 8 cm / 10 cm / 12 cm / 15 cm / 18 cm / 20 cm / 22 cm / 24 cm	60			
<b>FLEXIBLE BLADE PREMIUM JOINT KNIFE</b> 4 cm / 6 cm / 8 cm / 10 cm / 12 cm / 15 cm / 20 cm / 25 cm	62	90		
<b>FLEXIBLE MIXING BUCKET</b> - 42 l	113	244		
Flexible smoothing blade - <b>EDMABLADE</b> 15 cm / 25 cm / 35 cm / 45 cm / 60 cm / 80 cm / 100 cm	68	69	94	95
Flexible smoothing blade - <b>EDMABLADE</b> 60 cm / 80 cm / 100 cm	175			
FLOOR SQUEEGEE - 55 cm / 75 cm	130			
FLOORING TROWEL - 500 mm	245			
<b>FLYER'S</b> - Forged aviation snip	20	196		
<b>FLYER'S L 75</b> - Forged aviation snip - 75 mm long blades	196			
FOLDABLE HOT WIRE CUTTING TABLE For polystyrene, especially for E.T.I.C.S. applications	164	165		
FOLDABLE KNIFE	41			
FOLDABLE KNIFE WITH HOLSTER	41			
FOLDING TOOL - "Squeezing folding pliers"	214			
FOOT SWITCH FOR HOT WIRE CUTTING TABLES	165	167		
<b>FOOTPLAC</b> - Board lever with steel stirrup	39	147		
Forged aviation snip - 75 mm long blades - <b>FLYER'S L 75</b>	196			
Forged aviation snip - <b>FLYER'S</b>	20	196		
Forged aviation snip - Right cut / Left cut - <b>APOLLO</b>	20	197		
FORGED ROOFER'S HAMMER	182			
FORGED SHEARS PELICAN - 300 mm - Right cut / Left cut	198			
FRENCH SLATER'S HAMMER - Right handed / Left handed	192			

# G

GALVANIZED LOOP TIE WIRE - Ø 1 mm x 120 mm - x 1000 pcs	241	270		
GAP SPACER - x 10 pcs - 3 mm / 5 mm / 7 mm	256			
GAP SPACER - Assortment 3, 5, 7 mm - x 24 pcs	256			
GEL KNEE PADS	102	134		
GEL KNEE PADS WITH STABILIZING REINFORCEMENT	102	134		



GRADUATED MULTIFUNCTION BUCKET - 33 L	54	88	112	142
	174	180	243	250
GREEN PLASTIFIED LOOP TIE WIRE - Ø 1,4 mm x 200 mm x 1000 pcs	270			
GREY LEAD FOR <b>EDMARKER</b> - x 6 pcs	185	234		
GROOVE BLADE FOR <b>CANALCUT</b> - 35 x 35 mm	36	173		
GROOVE CUTTER FOR HOT KNIFE - Ø 30 mm	161			
GROOVING HAMMER	212			
GROOVING HAMMER DIFFERENT FACES	213			
GROUT FLOAT - Hard - 250 x 100 mm	127			
GROUT FLOAT - Medium - 270 x 130 mm	127			
GROUT SAW	131			
GROUT SPREADER - 200 mm	127			
GROUT SPREADER - 300 mm	127			
Guillotine for 48 mm metal studs and tracks, M6 threaded rod <b>DUOTOP</b>	25			
Guillotine for metal profiles up to 100 mm wide <b>PROFILCUT® MEGA</b>	24			
Guillotine for metal studs and tracks - <b>PROFILCUT®</b>	23			
Guillotine for metal studs and tracks - <b>STUD CUTTER</b>	22			
Guillotine to cut fiber cement siding - <b>ALPHACUT</b>	222			
Guillotine to cut fiber cement siding - <b>VARIOCUT</b>	223			
GUTTER HANGER BENDER	215			

## H

HALF MOON NOTCHED SPREADER - 300 mm - 20 x 10 mm	119			
HALF MOON NOTCHED TROWEL - 280 mm - 20 x 10 mm	119			
HALF ROUND KNIFE	66	93		
Hammer tackler - <b>PUNCHER</b>	186	255		
	81	99	131	147
HAND AND SURFACE CLEANING WIPE - x 90 pcs	175	227	247	275
Hand hog ring pliers - <b>BABY GRAFER 16/20</b>	261			
Hand hog ring pliers - <b>BABY GRAFER 30</b>	261			
Hand hog ring pliers with magazine - <b>JUNIOR</b>	264			
Hand hog ring pliers with magazine - <b>MAJOR</b>	264			
Hand hog ring pliers with magazine - <b>TOP GRAFER 16</b>	262			
Hand hog ring pliers with magazine - <b>TOP GRAFER 18</b>	262			
Hand hog ring pliers with magazine - <b>TOP GRAFER 20/22</b>	263			
Hand hog ring pliers with magazine - <b>TOP GRAFER 30</b>	263			
HAND STAPLER - For concertina ring installation	271			
HAND STAPLER WITH MAGAZINE For CL 50 gabion staple installation	274			
Hand tool for fixing corner beads - <b>CORNER FIX</b>	48			
HANDLE COILED SPRING - For hand hog ring pliers	260	261	262	263
HANGER SHIM - 33 x 40 mm - Assortment x 50 pcs / x 500 pcs / x 1000 pcs	253			
HANGER SHIM - x 1000 pcs 33 x 40 x 1 mm / 2 mm / 3 mm / 4 mm / 5 mm	253			
HAWK - 330 x 330 mm	67			
Heavy duty board lifter - <b>TRANSPLAC</b>	38			
HEAVY DUTY SCRAPER 150 mm / 300 mm / 500 mm	236			
HEAVY DUTY SCRAPER - 8 cm	53	87		
Hog ring pliers for "BECA" type round posts - <b>UNI-CLIP BECA</b>	260			
Hog ring pliers for round posts - <b>MASTER GRAFER</b>	260			
HOLDER FOR FOLDABLE HOT WIRE CUTTING TABLE	165			
HOLE SAW SET - Ø 60, 67, 74 mm	52			
HOLE SAW SET - Ø 60, 68, 74, 80, 90, 100 mm	52			
HORIZONTAL HOT WIRE CUTTING TABLE - For polystyrene	169	230		
<b>HOT BALL</b> - Stainless steel hot ball - Ø 35 mm	52			

Hot knife with air-cooling system - Hot knife + 3 blades set <b>EDMAFOAM</b>	160			
Hot knife with air-cooling system - Starting kit - <b>EDMAFOAM</b>	160			
HOT WIRE CORNER CUTTER - For polystyrene	168			
HOT WIRE CUTTING BOW - For polystyrene	172	231		
HOT WIRE CUTTING TABLE For polystyrene, especially for E.T.I.C.S. applications	166	167		

## I

INSIDE CORNER ROLLER	58			
INSIDE CORNER TROWEL	66	174		
<b>INSULACUT</b> Reciprocating electric saw for mineral insulation material	159			
INSULATION CUTTER - 300 mm / 420 mm	37	159		
<b>INTERCLIPS ZINC</b> Clinching pliers for zinc or enamel-plated aluminium gutters	215			
<b>INTERPERFOR</b> - Notch punching machine 3.5 x 15 mm	203			

## J

Job saw with teeth on both sides - 150 mm / 250 mm <b>CROCOPLAC II</b>	42			
JOINT KNIFE - 10 cm / 12.5 cm / 15 cm with 4 removable bits	61			
JOINT KNIFE STORAGE POUCH	18	61		
JOINT KNIFE WITH ROUNDED BLADE 10 cm / 12 cm / 14 cm / 16 cm / 18 cm / 20 cm / 22 cm / 24 cm / 30 cm	64	92		
<b>JUNIOR</b> - Hand hog ring pliers with magazine	264			

## L

Laminate and vinyl flooring guillotine - <b>STRATICUT® 230 LVT</b>	139			
Laminate flooring guillotine - 400 mm - <b>MEGA STRATICUT® 400</b>	141			
Laminate flooring guillotine - <b>STRATICUT® 230</b>	140			
LATHE AXE	183			
LEAD DRESSER	212			
LEATHER NAIL POUCH	178			
LEATHER TOOL POUCH	18	178		
LEVEL WITH XL MAGNETIC SLOTS - 90 cm / 120 cm	28			
Linear spacer - x 200 pcs - <b>EDMALEVEL SCREW</b> 1 mm / 2 mm / 3 mm	125			
<b>LIT' UP</b> - Wooden batten remover	181			
LITHIUM BATTERY 14.4 V - 1.5 AH FOR <b>INSULACUT</b>	159			
LITHIUM BATTERY 14.4 V - 2 AH FOR <b>EDMATYER</b>	239			
LITHIUM BATTERY 18 V - 2 AH	157	163	168	171
	233			
LITHIUM BATTERY 18 V - 4 AH	155			
LOWER JAW FOR TURBO 50 PREMIUM	273			

## M

Magnetic drywall screw retainer - <b>THE DIMPLER®</b>	48			
Magnetic system for making inspection hatches - <b>EDMAGNETIK</b>	118			
MAGNETIC TAPE MEASURE - 5 m x 25 mm / 8 m x 25 mm	19	234		
MAIN GAUGE - For <b>EDMATILE 600</b>	105			
MAIN GAUGE - For <b>EDMATILE 925</b>	105			
MAIN GAUGE - For <b>EDMATILE 1350</b>	105			
<b>MAJOR</b> - Hand hog ring pliers with magazine	264			
MARGIN TROWEL - 80 mm	120			
MARKLESS MALLET - 250 g / 500 g	121	145		
<b>MASTER GRAFER</b> - Hog ring pliers for round posts	260			

<b>MASTERCUT</b> - Slate cutting and punching pliers	190		
<b>MASTER-PROFIL®</b> One hand section setting pliers for studs and tracks	31		
<b>MAT</b> - Slate cutting and punching pliers, 35 mm blade	190		
<b>MAT 2</b> - Slate cutting and punching pliers, 55 mm blade	190		
<b>MAT COUP</b> - Slate cutting pliers, 35 mm blade	191		
<b>MAT COUP 2</b> - Slate cutting pliers, 55 mm blade	191		
<b>MAX LINE</b> - 50 m chalk line reel with large handle	27	185	235
<b>MAXI RET®</b> - 5 blades effortless swaging tool	216		
<b>MEGA STRATICUT®</b> 400 - 400 mm laminate flooring guillotine	141		
<b>MINERAL WOOL CUTTING TABLE</b>	158		
Mini plane for plasterboard - <b>EASY RAP</b>	40		
<b>MINI RODCUT M8</b> - Ø 4, 6, 8 mm rod guillotine	226		
<b>MINI RODUT M6</b> 6 mm (M6) threaded rod and 4 mm suspension wire cutter	26		
Mini trolley for board carrying - <b>ROLL PLAC</b>	38		
Mitre guillotine - <b>CAMELEON 130</b>	146		
Mitre shear for variable corners and angles - <b>MULTI-COUP®</b>	80	107	
Mitre shears with variable angle cuts - <b>MULTI-COUP® EXTRA</b>	146		
<b>MIXING PADDLE</b> - Ø 100 mm / 120 mm / 140 mm	113		
<b>MODULAR TRANSPORT CART</b>	114		
Monorail tile cutter - <b>EDMATILE 650</b>	104		
Monorail tile cutter - <b>EDMATILE 650 IN CARRYING CASE</b>	104		
Monorail tile cutter - <b>EDMATILE 950</b>	104		
Monorail tile cutter - <b>EDMATILE 950 IN CARRYING CASE</b>	104		
Monorail tile cutter - <b>EDMATILE 650</b>	104		
Monorail tile cutter - <b>EDMATILE 650 IN CARRYING CASE</b>	104		
Mouldings and PVC electric baseboards cutting pliers <b>PLURI COUP EXTRA</b>	80		
<b>MULTI COUP BOX</b>	81		
<b>MULTI PURPOSE TOOL</b> - 8 cm	53	87	
<b>MULTI-ANGLE CONTOUR GAUGE</b>	109	136	
<b>MULTI-COUP®</b> - Mitre shear for variable corners and angles	80	107	
<b>MULTI-COUP® EXTRA</b> - Mitre shears with variable angle cuts	146		
Multi-purpose farming tool - <b>PIC 7</b>	258		

## N

<b>NIBBLER HAND NOTCHER</b>	202		
<b>NIBBLER SHEARS NR1</b> - Nibbler shears	200		
Nibbler shears special corrugated iron with built-in waste curl cutter - <b>SUPERCOUPL NR3</b>	201		
Nibbler shears with built-in waste curl cutter - <b>SUPERCOUPL</b>	200		
<b>NIBBLEX® UNIVERSAL</b> - Adaptable nibbler shears on cordless power drills/screwdrivers	202		
Notch punching machine 3.5 x 15 mm - <b>INTERPERFOR</b>	203		
<b>NOTCHED SPREADER</b> - 300 mm 4 x 4 mm / 6 x 6 mm / 8 x 8 mm / 10 x 10 mm	119		
<b>NOTCHED TROWEL</b> - 280 mm 4 x 4 mm / 6 x 6 mm / 8 x 8 mm / 10 x 10 mm / 10 x 10 mm - 45° / 12 x 12 mm	119		
<b>NYLON CONTRACTOR RIG</b>	18	179	
<b>NYLON CONTRACTOR RIG XL</b>	18	179	

## O

Ø 1 MM BRAIDED SPARE ROPE FOR <b>FAST LINE</b> AND <b>ALU LINE</b>	27	235	
Ø 1.5 MM BRAIDED SPARE ROPE FOR <b>ROOF LINE</b>	184		
Ø 2.5 MM BRAIDED SPARE ROPE FOR <b>MAX LINE</b>	27	184	235
Ø 4, 6, 8 mm rod guillotine - <b>MINI RODCUT M8</b>	226		
Ø 6, 7, 8, 10 mm rod guillotine - <b>RODCUT</b>	225		
<b>OFFSET FORGED SHEARS</b> - 260 mm - Right cut / Left cut	199		

<b>OMEGA 16 STAPLE</b> - AISI 316 stainless steel - x 1250 pcs	266		
<b>OMEGA 16 STAPLE</b> - Galvanized A - x 250 pcs / x 1250 pcs / x 2500 pcs	266		
<b>OMEGA 16 STAPLE</b> - Galvanized dark grey PVC coated x 250 pcs / x 1250 pcs	266		
<b>OMEGA 16 STAPLE</b> - Galvanized green PVC coated x 250 pcs / x 1250 pcs / x 2500 pcs	266		
<b>OMEGA 18 STAPLE</b> - Galvanized A - x 1200 pcs	266		
<b>OMEGA 18 STAPLE</b> - Galvanized green PVC coated - x 3000 pcs	266		
<b>OMEGA 20 STAPLE</b> - AISI 316 stainless steel - x 1000 pcs	267		
<b>OMEGA 20 STAPLE</b> - Aluminium - x 1000 pcs	267		
<b>OMEGA 20 STAPLE</b> - Galvanized A - x 200 pcs / x 1000 pcs	267		
<b>OMEGA 20 STAPLE</b> - Galvanized black PVC coated - x 1000 pcs	267		
<b>OMEGA 20 STAPLE</b> - Galvanized dark grey PVC coated 200 pcs / x 1000 pcs	267		
<b>OMEGA 20 STAPLE</b> - Galvanized green PVC coated 200 pcs / x 1000 pcs	267		
<b>OMEGA 20 STAPLE</b> - Galvanized white PVC coated - x 200 pcs	267		
One hand section setting pliers for all types of studs and tracks, without any effort - <b>ULTRA PROFIL®</b>	32		
One hand section setting pliers for studs and tracks <b>MASTER-PROFIL®</b>	31		
<b>OSCILOCUT</b> Vibrating wire cutting table for insulation materials	156	157	
<b>OSCILOCUT IN CARRYING CASE</b> Vibrating wire cutting table for insulation materials	156	157	
<b>OSCILOCUT XL IN CARRYING CASE</b> Vibrating wire cutting table for large size insulation materials	156	157	
<b>OUTSIDE CORNER ROLLER</b>	58		
<b>OUTSIDE CORNER TROWEL</b>	66	174	

## P

<b>PACK 2 BATTERIES 18 V - 2 AH + DUAL CHARGER</b> FOR LITHIUM BATTERY 18 V	157	163	168	171
	231			
<b>PACK LITHIUM BATTERY 36 V - 2 AH</b>	165	167	169	172
	230	231		
<b>PACK LITHIUM BATTERY 36 V - 2 AH</b>	165	167	169	230
<b>PATCHUP</b> - 15 cm plasterboard repairer	53			
<b>PH2 DRYWALL BIT</b> - x 6 pcs	48			
<b>PH2 DRYWALL BIT FOR THE DIMPLER®</b>	48			
<b>PIC 7</b> - Multi-purpose farming tool	258			
Pipe cutting tool - Ø 16, 20 and 25 mm - <b>TRIOCOUP'</b>	224			
<b>PIPE POSITIONER</b> - Small variable angle vice	217			
<b>PLAC &amp; ROLL</b> - Drywall stripper	43			
Plane for plasterboards & wood - <b>VARIO RAP</b>	40			
Plasterboard repairer - 15 cm - <b>PATCHUP</b>	53			
<b>PLASTERBOARD SAW</b> - 550 mm	42			
<b>PLASTERING TROWEL</b> - Beveled stainless steel blade	67			
<b>PLASTERING TROWEL</b> - Curved stainless steel blade	67			
<b>PLASTERING TROWEL</b> - Flat stainless steel blade	67			
<b>PLASTIC BOTTLE</b> - 500 ml	217			
<b>PLASTIC MUD PAN</b> - 250 mm	55			
<b>PLURI COUP EXTRA</b> Mouldings and PVC electric baseboards cutting pliers	80			
<b>PLURICOUP® ERGO</b> - Multi purpose pliers with angled blades	20	258		
Pneumatic gun for CL 50 gabion staple installation <b>TURBO 50 PREMIUM</b>	273			
<b>POLYPERFOR</b> - Punching machine	203			
<b>POWER GRAFER</b> Adaptable hog ring pliers on cordless power drills/screwdrivers	265			
<b>POWER PROFIL</b> - Automatic section setting pliers for all types of studs and tracks, fits on cordless power drills/screwdrivers	34			

Precision insulation cutter - <b>CANALCUT</b>	36	173		
PRECISION SCRAPER + 7 BLADES	86			
PREMIUM CARPENTER'S HAMMER	182			
PREMIUM MULTIPURPOSE Mallet - 250 g / 500 g	121	145	257	
<b>PRESS DECK®</b> - Decking lath straightener	256			
PRESSURE ROLLER - 28 mm / 45 mm / 90 mm width	218			
PRESSURE ROLLER - 45° angled - 45 mm width	218			
<b>PRO MAT-COUP 210</b> - Slate cutter	189			
<b>PROFIL</b> - Section setting pliers for studs and tracks	30			
<b>PROFIL 2 RM</b> - Section setting pliers for studs and tracks	30			
<b>PROFILCUT®</b> - Guillotine for metal studs and tracks	23			
<b>PROFILCUT® MEGA</b> Guillotine for metal profiles up to 100 mm wide	24			
PROTECTION PAD - x 24 pcs 78 x 78 x 8 mm / 100 x 100 x 10 mm	254			
PROTECTIVE STRIP 16 m x 80 mm / 20 m x 60 mm / 20 m x 100 mm	254			
Pulling bar for laminate flooring installation - <b>SUPER TAK-TIK</b>	144			
PUNCH + DIE FOR <b>INTERPERFOR 3,5 x 15 MM</b>	203			
PUNCH + DIE SET FOR <b>NIBBLEX® UNIVERSAL</b>	202			
PUNCH FOR <b>MAT AND MAT 2</b>	191			
PUNCH SET FOR <b>POLYPERFOR</b> : Ø 3,3 mm / Ø 4,1 mm / Ø 4,9 mm / Ø 6,2 mm	203			
<b>PUNCHER</b> - Hammer tackler	186	255		
Punching machine - <b>POLYPERFOR</b>	203			

## Q

QUICK SUPPORT 75-125 cm / 101-177 cm / 160-290 cm / 210-390 cm	44			
---	----	--	--	--

## R

Rack and pinion panel lifter - <b>EDMAPLAC 450</b>	44	45	46	
<b>RAP-PLAC VERSATILE</b> - Chamfering plane for plasterboard	43			
REBAR GUILLOTINE	237			
Reciprocating electric saw for mineral insulation material <b>INSULACUT</b>	159			
RECOVERABLE TILE SPACER - x 100 pcs 1.5 mm / 2 mm / 2.5 mm	120			
RECOVERABLE TILE SPACER - 3 mm - x 75 pcs	120			
RECOVERABLE TILE SPACER - 4 mm - x 50 pcs	120			
RECOVERABLE TILE SPACER - 5 mm - x 40 pcs	120			
RECTANGULAR TINMAN'S Mallet	213			
RED MARKING CHALK - 200 g / 400 g / 1000 g / 3500 g	27	185	235	
REINFORCED JOINT KNIFE - 20 cm / 25 cm / 30 cm / 35 cm	65			
REPAIR KIT FOR <b>MAT AND MAT 2</b>	191			
REPLACEABLE DIE FOR <b>RODCUT</b>	225			
REPLACEABLE JAW FOR <b>CORNER FIX</b> - x 2 pcs	48			
REPLACEABLE TIP FOR <b>CORNER FIX AND SUPER TAK-TIK</b>	48	144		
RET 3 BLADES - 3 blades swaging tool - Special for square pipes	216			
RET 5 BLADES - 5 blades swaging tool	216			
RING FOR CONCERTINA - Galvanized - x 1000 pcs	271			
<b>RODCUT</b> - Ø 6, 7, 8, 10 mm rod guillotine	225			
<b>ROLL MAT</b> - 600 mm slate cutter	188			
<b>ROLL PLAC</b> - Mini trolley for board carrying	38			
ROLLER KNEE SUPPORTS	103	135		
<b>ROOF LINE</b> - 30 m chalk line reel special for roofers	184			
ROOFER'S HAMMER	182			
ROOFER'S ADZE	183			
ROOFER'S HOLDER - Soldering iron tip cleaning set	214			
RUBBER JOINT KNIFE	67			

## S

SAFETY KNIFE	41			
SCAFFOLDING SUPPORT FOR HOT WIRE CUTTING TABLE	167			
SCISSORS SPECIAL FOR PLASTIC SHEETS	217			
SCRIBE TIP	107			
SCRIBER TOOL	195			
SEAM OPENING PLIERS	210			
SEAMING IRON - With flat blade	214			
SEAMING PLIERS - Straight - 180 mm / 200 mm	209			
Section setting pliers for all types of studs and tracks <b>ERGOTOP®</b>	31			
Section setting pliers for back-to-back studs - <b>DUO PROFIL</b>	33			
Section setting pliers for back-to-back studs - <b>TWIN PROFIL®</b>	33			
Section setting pliers for studs and tracks - <b>PROFIL</b>	30			
Section setting pliers for studs and tracks - <b>PROFIL 2 RM</b>	30			
SELF-ADHESIVE WATERPROOFING STRIP - 20 m x 80 mm	254			
Self-levelling system starting kit - <b>EDMALEVEL SCREW</b> 1 mm / 2 mm	124			
SEMI-CIRCULAR DORMER SQUARE SEAM FOLDER	210			
SET OF EDMABLADE + STORAGE CASE S / XL	70	96		
SET OF JOINT KNIVES + STORAGE POUCH	61			
SET OF PREMIUM JOINT KNIVES + STORAGE POUCH	63	91		
<b>SET TAK-TIK</b> - Complete set for installing laminate flooring*	143			
SETTING STICK	212			
Shears "PASSE-FRANC" - Right cut / Left cut - <b>UPPER-CUT</b>	197			
SINGLE BENDER 2 ROLLS Tool to make folds, counterfolds, raised areas on sheets	205			
SINGLE BENDER 4 ROLLS - Tool to make folds, counterfolds, raised areas on sheets - 200 mm / 350 mm	205			
SINGLE DISK ROLLER Tool to make bends from 90° to 180° maximum	206			
SINGLE SUCTION CUP	116			
SINGLE USE TILE SPACER x 1000 pcs / 2 mm / 3 mm	120			
SINGLE VACUUM SUCTION CUP	116			
SINGLE-USE TILE SPACER - x 300 pcs / 1.5 mm / 2 mm	120			
SINGLE-USE TILE SPACER - x 200 pcs / 3 mm / 4 mm	120			
Slate cutter - 600 mm - <b>ROLL MAT</b>	188			
Slate cutter - <b>PRO MAT-COUP 210</b>	189			
Slate cutting and punching pliers - <b>MASTERCUT</b>	190			
Slate cutting and punching pliers, 35 mm blade - <b>MAT</b>	190			
Slate cutting and punching pliers, 55 mm blade - <b>MAT 2</b>	190			
Slate cutting pliers, 35 mm blade - <b>MAT COUP</b>	191			
Slate cutting pliers, 55 mm blade - <b>MAT COUP 2</b>	191			
SLATE RIPPER - 400 mm / 600 mm	194			
SLATER'S ANVIL - 400 mm - Right handed / Left handed	192			
SNAP OFF KNIFE WITH ZINC-ALLOY BODY - 9 mm / 18 mm	41			
SNAP-OFF BLADE - 25 mm - x 10 pcs	41			
SPACER BLOCK - x 48 pcs	143			
SPARE BLADE FOR GROUT SAW	131			
SPARE BLADE FOR HOT KNIFE - 15 cm / 20 cm / 25 cm	161			
SPARE BLADE FOR <b>INSULACUT</b> - 300 mm	159			
SPARE BLADE FOR PRECISION SCRAPER - x 6 pcs	86			
SPARE BLADE FOR TRIANGULAR PAINTER'S SCRAPER	86			
SPARE BLADES KIT FOR <b>TURBOSHEAR</b>	201			
SPARE CUTTING DISC FOR <b>ROLL MAT</b>	188			
SPARE CUTTING WIRE FOR ADJUSTABLE BLIND HOLE CUTTER	161			
SPARE CUTTING WIRE FOR BOWS AND HORIZONTAL TABLE 1370 MM	169	172	230	231

SPARE CUTTING WIRE FOR DOUBLE HOT WIRE CUTTING TABLE 370 MM / 1430 MM	163			
SPARE CUTTING WIRE FOR HOT WIRE CORNER CUTTER 610 MM	168			
SPARE CUTTING WIRE FOR HOT WIRE CUTTING TABLE 1500 MM	167			
SPARE CUTTING WIRE FOR <b>STYROGUN</b> - 678 MM	171	233		
SPARE CUTTING WIRE ROLL FOR FOLDABLE HOT WIRE CUTTING TABLE - 2 M	165			
SPARE DIE FOR <b>MINI RODCUT M6</b> AND <b>DUOTOP</b>	25	26		
SPARE HANDLE SPRING FOR <b>JUNIOR</b>	264			
SPARE HANDLE SPRING FOR <b>MAJOR</b>	264			
SPARE PAD FOR CLEANING FLOAT - 250 x 100 mm	129			
SPARE PUNCH FOR <b>MASTERCUT</b>	191			
SPARE PUNCHING BLADE FOR <b>DUO PROFIL</b>	33			
SPARE PUNCHING BLADE FOR <b>MASTER-PROFIL®</b>	31			
SPARE PUNCHING BLADE FOR <b>PROFIL</b>	30			
SPARE PUNCHING BLADE FOR <b>PROFIL 2 RM, ERGOTOP®, POWER PROFIL ET TWIN PROFIL®</b>	30	31	33	34
SPARE PUNCHING BLADE FOR <b>ULTRA PROFIL®</b>	32			
SPARE SPRING FOR <b>MASTERCUT</b>	191			
SPARE SPRING FOR <b>MASTER-PROFIL®</b> - x 5 pcs	31			
SPARE TRIANGULAR BLADE FOR PRECISION SCRAPER	86			
SPARE WHEEL FOR <b>PLAC &amp; ROLL</b> - x 2 pcs	43			
SPONGE FLOAT - 280 X 140 mm	128			
SPRING FOR <b>MAT COUP, MAT COUP 2</b> AND <b>MAXI RET®</b> x 5 pcs	191	216		
SQUARE SEAM FOLDER	210			
Stackable storage box - <b>EDMABOX</b>	16			
STAINLESS STEEL BLADE FOR <b>MULTI-COUP® EXTRA</b> AND <b>PLURI COUP EXTRA</b> - 65 mm	80	146		
STAINLESS STEEL BLADE FOR <b>TRIOCOUP'</b>	224			
Stainless steel hot ball - Ø 35 mm - <b>HOT BALL</b>	52			
STAINLESS STEEL MUD PAN - 300 mm	55			
<b>STAPLE FOR PUNCHER</b> 8 mm x 1000 pcs / 10 mm x 1000 pcs / 10 mm x 5000 pcs 12 mm x 1000 pcs / 14 mm x 1000 pcs	186	255		
Starting kit 100 pcs - <b>EDMALEVEL SELF-LEVELLING SYSTEM</b> 1.5 mm / 2 mm	122			
STEEL PRESSURE ROLLER - 40 mm width / 60 mm width	219			
STEP DRILL Use for precision drilling of sheet metal and plastic up to 30 mm	36			
STEP STOOL - 3 steps double sided	50			
STIFF BLADE JOINT KNIFE - 4 cm / 5 cm / 8 cm / 10 cm	60			
STIFF BLADE PREMIUM JOINT KNIFE 4 cm / 5 cm / 8 cm / 10 cm	62	90		
Stiff smoothing blade - <b>EDMABLADE</b> 15 cm / 25 cm / 35 cm / 45 cm / 60 cm / 80 cm / 100 cm	68	69	94	95
Stiff smoothing blade - <b>EDMABLADE</b> 60 cm / 80 cm / 100 cm	175			
STORAGE CASE S / XL	16	72	99	
<b>STRATICUT® 230</b> - Laminate flooring guillotine	140			
<b>STRATICUT® 230 LVT</b> - Laminate and vinyl flooring guillotine	139			
STRIPPING STONE - For roofer's holder	214			
<b>STUD CUTTER</b> - Guillotine for metal studs and tracks	22			
<b>STYROGUN</b> - Cordless hot wire cutter for polystyrene	170	171	232	233
<b>STYROGUN WITHOUT BATTERY OR CHARGER</b> Cordless hot wire cutter for polystyrene	170	171	232	233
<b>SUPER TAK-TIK</b> - Pulling bar for laminate flooring installation	144			
<b>SUPERCOUNP</b> - Nibbler shears with built-in waste curl cutter	200			
<b>SUPERCOUNP NR3</b> - Nibbler shears special corrugated iron with built-in waste curl cutter	201			
<b>SUPER-FIX®</b> - Expansion gun for all metal anchors	79			
<b>SUPRA-FIX®</b> - Expansion gun for all metal anchors	79			

Swaging tool - 5 blades - <b>MAXI RET®</b>	216			
Swaging tool - <b>RET 5 BLADES</b>	216			
Swaging tool - Special for square pipes - <b>RET 3 BLADES</b>	216			

## T

T spacer 2 mm - x 200 pcs - <b>EDMALEVEL SCREW</b>	125			
Tapping block for hardwood and laminate flooring <b>BLOC PARKET</b>	144			
TELESCOPIC POLE 0,55 - 0,90 m / 1,50 m / 2,40 m	73	98		
Telescopic wooden batten remover - <b>DECHAUSS' TOUT</b>	181			
<b>THE DIMPLER®</b> - Magnetic drywall screw retainer	48			
Threaded rod and 4 mm suspension wire cutter - 6 mm (M6) <b>MINI RODUT M6</b>	27			
TILE CUTTING PLIERS	107			
Tile joint kit + accessories - 24 I - <b>EDMACLEAN</b>	126			
TILE LIFTER - Adjustable from 280 to 665 mm / 280 to 800 mm	115	220	246	
Tile spacer - 1 mm - x 500 pcs <b>EDMALEVEL SELF-LEVELLING SYSTEM</b>	123			
Tile spacer - 1.5 mm - x 250 pcs / x 500 pcs / x 1000 pcs <b>EDMALEVEL SELF-LEVELLING SYSTEM</b>	123			
Tile spacer - 2 mm - x 250 pcs / x 500 pcs / x 1000 pcs <b>EDMALEVEL SELF-LEVELLING SYSTEM</b>	123			
Tile spacer - 3 mm - x 500 pcs <b>EDMALEVEL SELF-LEVELLING SYSTEM</b>	123			
TILE SPONGE - 190 x 130 x 50 mm / 200 x 100 x 60 mm	128			
TILE WEDGE - 5 mm - x 500 pcs	120			
Tile wedge - x 250 pcs - <b>EDMALEVEL SELF-LEVELLING SYSTEM</b>	123			
TOOL TRAY - <b>EDMABOX</b> compatible	17			
<b>TOP GRAFER 16</b> - Hand hog ring pliers with magazine	262			
<b>TOP GRAFER 18</b> - Hand hog ring pliers with magazine	262			
<b>TOP GRAFER 20/22</b> - Hand hog ring pliers with magazine	263			
<b>TOP GRAFER 30</b> - Hand hog ring pliers with magazine	263			
<b>TORNADO</b> - Automatic binder for loop tie wire	241	270		
TRADITIONAL SLATER'S HAMMER - Right handed / Left handed	193			
TRANSFORMER FOR FOLDABLE HOT WIRE CUTTING TABLE	165			
TRANSFORMER FOR HOT WIRE CUTTING TABLES AND BOW	167	169	172	230
TRANSFORMER FOR TABLE 368155	231			
TRANSFORMER FOR TABLE 368155	163			
TRANSPARENT LID FOR 33 L GRADUATED MULTIFUNCTION BUCKET	54	88	112	142
<b>TRANSPAC</b> - Heavy duty board lifter	174	180	243	250
TRAPEZE BLADE FOR CUTTER - x 10 pcs	38			
TRAPEZE CUTTER BLADE DISPENSER	41	43	80	107
TRIANGULAR PAINTER'S SCRAPER	41			
TRIOCOUP' - Pipe cutting tool - Ø 16, 20 and 25 mm	86			
TRIOCOUP' - Pipe cutting tool - Ø 16, 20 and 25 mm	224			
TRIPLE SUCTION CUP	116			
T-Spacer x 200 pcs - 1 mm / 2mm / 3 mm - <b>EDMALEVEL SCREW</b>	125			
<b>TURBO 24</b> - Pneumatic gun for CL 24 staple installation	240	272		
<b>TURBO 50 PREMIUM</b> Pneumatic gun for CL 50 gabion staple installation	273			
<b>TURBOSHEAR</b> Adaptable shears on cordless power drills/screwdrivers	201			
<b>TURBOSHEAR FIBER CEMENT</b> - Adaptable fiber cement shears on cordless power drills/screwdrivers	224			
<b>TWIN PROFIL®</b> - Section setting pliers for back-to-back studs	33			
TWIN SQUARE SEAM FOLDER	210			
TYING HEAD FOR <b>EDMATYER</b> - 24 mm / 40 mm	239			

## U

<b>ULTRA PROFIL®</b> - One hand section setting pliers for all types of studs and tracks, without any effort	32			
--	----	--	--	--

<b>ULTRA-FIX®</b> - Expansion gun for all metal anchors	79			
<b>UNI-CLIP BECA</b> - Hog ring pliers for "BECA" type round posts	260			
UNIVERSAL FORGED SHEARS - 250 mm Wide and narrow blade shears	198			
UNIVERSAL SLATER'S HAMMER - Right handed / Left handed	193			
UPPER JAW FOR TURBO 50 PREMIUM	273			
<b>UPPER-CUT</b> - Shears "PASSE-FRANC" - Right cut / Left cut	197			

## V

VACUUM HOOD FOR WOOLCUT	155			
<b>VARIO RAP</b> - Plane for plasterboards & wood	40			
<b>VARIOCUT</b> - Guillotine to cut fiber cement siding	223			
Vibrating wire cutting table for insulation materials <b>OSCILOCUT</b>	156	157		
Vibrating wire cutting table for insulation materials <b>OSCILOCUT IN CARRYING CASE</b>	156	157		
Vibrating wire cutting table for large size insulation materials <b>OSCILOCUT XL IN CARRYING CASE</b>	156	157		

## W

WATERPROOF FLOOR HATCH - 60 x 60 cm	118			
WATERPROOF STAINLESS STEEL FLOOR HATCH 30 x 30 cm / 40 x 40 cm	118			
WEDGE - 150 x 45 x 25 mm - x 6 pcs	251			
WEDGE - 80 x 30 x 10 mm - x 30 pcs	251			
WEDGE - 80 x 40 x 8 mm - x 30 pcs	251			
WEDGE - 90 x 45 x 15 mm - 100 pcs	251			
WEDGE - 90 x 45 x 15 mm - x 16 pcs	251			
WEDGE - Assortment - x 245 pcs	251			
WELD SEAM TESTER	217			
WIRE FOR <b>OSCILOCUT XL</b>	157			
WIRE NET FENCING PACK	259			
Wire tensioner for netting and welded nets - <b>DRESS FIL</b>	271			
WOOD HANDLE Ø 28,5 mm - 180 CM - For concrete spreader	244			
WOOD HANDLE Ø 32 MM - 110 CM - For heavy duty scraper	236			
Wooden batten remover - <b>LIT' UP</b>	181			
<b>WOOLCUT</b> - Cordless electric saw for biobased and mineral insulation materials	154	155		

## X

XL tile spacer - 1.5 mm / 2 mm - x 250 pcs <b>EDMALEVEL SELF-LEVELLING SYSTEM</b>	123			
--	-----	--	--	--

## Z

ZINC AND LAMINATE SCRIBER	195			
---------------------------	-----	--	--	--

# BIBLIOGRAPHICAL INDEX

Ref.	EAN code	Net weight	PCB	Pages		Ref.	EAN code	Net weight	PCB	Pages	
010155	3476060001016	0,47	5	200		032155	3476060003218	0,8	20	192	
010255	3476060001023	0,53	5	197		032255	3476060003225	0,8	20	192	
010655	3476060001061	0,376	5	196		032455	3476060003249	0,82	5	190	
010755	3476060001078	0,46	5	20	196	032555	3476060003256	0,661	5	191	
010955	3476060001092	0,496	5	20	197	032855	3476060003287	0,225	10	187	
011055	3476060001108	0,489	5	200		032955	3476060003294	0,25	20	195	
011355	3476060001139	0,48	5	201		033055	3476060003300	2,182	1	189	
012055	3476060001207	0,48	5	198		033155	3476060003317	0,125	5	195	
012255	3476060001221	0,515	5	199		033255	3476060003324	1,59	2	181	
012355	3476060001238	0,52	5	199		033955	3476060003393	0,487	5	213	
012455	3476060001245	0,52	5	199		034155	3476060003416	0,53	5	203	
012555	3476060001252	0,53	5	199		034255	3476060003423	0,169	5	208	
012655	3476060001269	0,73	5	198		034455	3476060003447	0,655	5	208	
017255	3476060001726	0,38	5	202		034555	3476060003454	0,95	5	208	
017455	3476060001740	0,08	50	202		034855	3476060003485	0,57	5	209	
018455	3476060001849	0,135	50	203		035055	3476060003508	0,72	5	216	
018555	3476060001856	1,12	5	203		035155	3476060003515	2,3	1	214	
020155	3476060002013	0,3	5	78		035255	3476060003522	3,12	2	214	
020355	3476060002037	0,435	5	78		035455	3476060003546	0,82	10	214	
021155	3476060002112	0,41	5	78		035555	3476060355553	11,93	1	188	
021355	3476060002136	0,42	5	79		035855	3476060003584	0,813	5	182	
023155	3476060002310	0,41	5	79		035955	3476060003591	0,961	5	182	
023255	3476060002327	0,51	5	79		036055	3476060003607	0,49	5	215	
030055	3476060003003	0,487	5	216		036155	3476060003614	0,07	100	195	
030355	3476060003034	0,419	5	216		036255	3476060362551	0,96	5	182	
030555	3476060003058	2,51	5	209		036455	3476060003645	0,205	5	214	
030655	3476060003065	2,59	5	209		036755	3476060003676	0,88	5	183	
031055	3476060003102	0,8	5	190		037055	3476060003706	5,12	1	222	
031255	3476060003126	0,014	100	191		037255	3476060003720	0,44	5	212	
031555	3476060003157	0,023	100	191		037355	3476060003737	1,175	2	183	
031755	3476060003171	0,036	50	191	216	037655	3476060003768	0,7	5	194	
031855	3476060003188	0,98	5	186	255	037755	3476060003775	0,85	5	194	
031955	3476060003195	0,695	20	186	255	038155	3476060003812	0,65	5	192	
032055	3476060003201	0,61	5	191		038255	3476060003829	0,676	5	192	
						038355	3476060003836	0,78	5	193	



Ref.	EAN code	Net weight	PCB	Pages
038455	3476060003843	0,666	5	193
038655	3476060003867	1,93	5	210
038755	3476060003874	2,33	5	210
038855	3476060003881	4,21	1	226
038955	3476060003898	1,02	5	201
039055	3476060003904	0,163	50	203
039155	3476060003911	0,21	5	208
039355	3476060003935	0,64	5	208
039455	3476060003942	1,01	5	208
039555	3476060003959	0,87	5	208
039655	3476060003966	0,697	5	193
039855	3476060003980	1,528	10	221
040055	3476060004000	0,54	5	264
040155	3476060004017	0,33	5	262
040355	3476060004031	0,361	5	262
040455	3476060004048	0,341	6	242 259
040555	3476060004055	0,4	5	263
040655	3476060004062	0,215	5	261
040755	3476060004079	0,275	5	271
040801	3476060408013	0,064	25	266
040901	3476060409010	0,27	30	266
041055	3476060004109	0,98	5	264
041155	3476060004116	0,39	5	263
041255	3476060004123	0,2	5	261
041455	3476060004147	0,989	5	265
041501	3476060004154	0,076	25	266
041601	3476060004161	0,713	24	266
041855	3476060004185	1,427	5	259
041901	3476060004192	0,355	30	266
042001	3476060004208	0,8	20	267
042101	3476060004215	0,283	30	267
042301	3476060004239	0,878	30	267
042455	3476060004246	0,596	5	258
042501	3476060004253	0,173	15	267
042601	3476060426017	0,168	15	267
042855	3476060004284	0,52	5	260
042900	3476060004291	0,15	15	267
043001	3476060004307	0,715	20	267
043201	3476060432018	0,725	20	267
043501	3476060004352	0,149	15	267
043700	3476060004376	1,54	8	269
043855	3476060004383	0,495	5	260
044001	3476060004406	0,446	24	266
044201	3476060004420	0,27	30	266
044300	3476060004437	0,384	30	266
044501	3476060004451	0,055	25	266
044855	3476060004482	0,4	6	242 259
045555	3476060004550	0,324	20	241 270
046455	3476060004642	5,055	1	274
046500	3476060004659	2,971	6	268
046601	3476060004666	3,03	1	271
046801	3476060004680	0,24	30	269

Ref.	EAN code	Net weight	PCB	Pages
046901	3476060004697	0,239	30	269
047101	3476060004710	0,553	30	268
047201	3476060004727	0,625	20	267
047300	3476060004734	2,48	8	269
047400	3476060004741	2,3	8	269
047755	3476060004772	0,26	50	271
048455	3476060004840	0,39	5	265
049055	3476060004901	0,01	50	264
049255	3476060004925	0,013	50	260 261 262 263
049555	3476060495556	6,735	1	273
049855	3476060004987	1,213	1	240 272
050155	3476060005014	0,206	5	217
060055	3476060006004	0,89	5	30
060155	3476060006011	0,045	50	30
060355	3476060603555	1,356	5	33
060555	3476060006059	0,128	15	27 235
060655	3476060006066	0,214	6	41
060755	3476060006073	0,14	15	27 235
060955	3476060006097	0,6	18	27 185 235
061055	3476060006103	0,67	5	30
061655	3476060616555	6,225	1	25
061755	3476060006172	8,305	1	23
061855	3476060006189	0,011	50	30 31 33 34 35
061955	3476060006196	0,72	5	31
062055	3476060006202	0,68	5	31
062155	3476060006219	0,015	100	31
062255	3476060006226	0,031	50	31
062855	3476060006288	0,86	5	48
062955	3476060006295	0,75	6	43
063155	3476060006318	1	12	27 185 235
063255	3476060006325	0,4	6	27 185 235
063355	3476060006332	0,2	6	27 185 235
063855	3476060006387	0,2	6	27 185 235
064055	3476060006400	1,1	5	39
064255	3476060006424	0,25	6	184
064355	3476060006431	1	12	27 185 235
064555	3476060006455	1,37	2	38
064655	3476060646552	2,68	4	38
064755	3476060006479	0,22	5	40
064955	3476060006493	0,4	6	27 185 235
065055	3476060006509	4,12	1	26
065155	3476060006516	3,5	6	27 185 235
065255	3476060006523	3,5	6	27 185 235
065455	3476060006547	0,18	2	66 174
065755	3476060006578	0,18	2	66 174
065855	3476060006585	14,2	1	24
065955	3476060006592	7,41	1	225
066055	3476060006608	1,025	5	39 147
066155	3476060006615	2,2	2	44
066355	3476060006639	1,37	10	44
066455	3476060006646	0,2	10	37 159

Ref.	EAN code	Net weight	PCB	Pages
066555	3476060006653	1,6	6	39
066655	3476060006660	0,542	5	55
066755	3476060006677	0,1	50	40
066855	3476060006684	0,781	5	32
066955	3476060006691	0,322	5	55
067055	3476060006707	0,18	5	42
067255	3476060006721	0,195	5	42
067855	3476060006783	3,1	2	44
068155	3476060006813	0,135	10	36 173
068655	3476060006868	0,162	20	22 25
068855	3476060688552	2,1	2	44
069055	3476060006905	0,635	10	36 173
069255	3476060006929	0,53	5	43
069555	3476060006950	0,105	15	36 173
069855	3476060006981	0,29	5	55
069955	3476060006998	0,6	6	67
070055	3476060007001	0,39	5	80 107
071055	3476060007100	0,35	5	146
071155	3476060007117	0,028	50	80 146
073155	3476060007315	0,47	5	224
073255	3476060007322	0,045	50	224
074555	3476060007452	0,13	10	20 258
075055	3476060007506	0,346	5	80
085055	3476060008503	2,95	1	146
085355	3476060008534	3,348	1	254
085455	3476060008541	0,104	10	256
085555	3476060008558	0,124	10	256
085655	3476060008565	0,144	10	256
085755	3476060008572	0,297	6	256
085855	3476060858559	0,5	24	254
086555	3476060008657	2,4	2	256
086755	34760600867551	4,3	1	254
086855	3476060868558	2,8	1	254
087055	3476060008701	0,834	18	143
087255	3476060008725	1,95	2	144
087355	3476060008732	0,272	10	143
087555	3476060008756	2,246	2	181
088255	3476060008824	0,4	32	108 137
089055	3476060008909	6,2	1	140
089355	3476060893550	6,6	1	139
089955	3476060008992	10,44	1	223
090055	3476060009005	0,54	10	236
090155	3476060009012	0,345	10	236
092755	3476060009272	0,231	6	245
092855	3476060009289	0,23	6	245
095055	3476060009500	0,78	6	236
096055	3476060009609	1,3	5	244
101055	3476060010100	0,023	50	200
102055	3476060010209	0,508	5	197
103055	3476060010308	0,024	100	201
105055	3476060010506	0,022	100	201

Ref.	EAN code	Net weight	PCB	Pages
109055	3476060010902	0,486	5	20 197
111055	3476060011107	0,035	50	200
126055	3476061260559	0,75	5	198
130155	3476060013019	1,925	1	205
130255	3476060013026	0,905	1	206
130355	3476060013033	1,415	1	205
130455	3476060013040	3,49	1	204
130555	3476060013057	0,494	5	178
130655	3476060013064	2,605	1	207
130755	3476060013071	0,855	1	206
130855	3476060013088	3,92	1	204
130955	3476060013095	2,29	1	205
131155	3476060013118	0,44	5	210
131255	3476060013125	0,177	5	194
131355	3476060013132	0,49	10	194
131855	3476060013187	3,85	6	215
132155	3476060013217	0,289	5	212
132255	3476060013224	0,887	10	211
132355	3476060013231	2,1	10	211
132555	3476060013255	0,745	5	210
132655	3476060013262	0,249	5	212
132755	3476060013279	0,297	5	212
132855	3476060013286	0,182	5	212
132955	3476060013293	0,204	10	185
133055	3476060013309	0,59	5	202
133355	3476060013330	0,044	100	187
134255	3476060013422	0,158	15	218
134355	3476060013439	0,195	5	218
134455	3476060013446	0,2	15	218
134555	3476060013453	0,129	15	219
134655	3476060013460	0,372	15	218
134755	3476060013477	0,445	15	219
134855	3476060013484	0,61	15	219
134955	3476060013491	0,11	15	217
135055	3476060013507	0,375	15	217
135155	3476060013514	0,079	20	217
135255	3476060013521	0,368	5	213
135355	3476060013538	0,43	5	213
135955	3476060013590	1,7	10	211
136455	3476060013644	0,125	20	214
138855	3476060013880	0,113	20	226
138955	3476060013897	0,195	10	201
139655	3476060013965	0,675	5	193
140001	3476060014009	4,78	1	269
146800	3476060014689	1,25	10	269
149155	3476060014917	0,008	100	264
150000	3476060015006	6,625	1	273 274
160000	3476060016003	6,725	1	273 274
160455	3476060016041	1,36	5	33
160555	3476060016058	0,021	10	27 235
160655	3476060016065	0,292	6	41
160755	3476060016072	0,18	12	41

Ref.	EAN code	Net weight	PCB	Pages
161155	3476060016119	7,02	2	51
161255	3476060016126	0,278	5	76
161355	3476060016133	0,19	8	76
161455	3476060016140	1,075	5	34
161555	3476060016157	3,645	1	22
162255	3476060016225	0,241	10	52
162355	3476060016232	0,65	5	52
162655	3476060016263	0,153	10	36
162855	3476060016287	0,023	50	48
163155	3476060016317	0,61	10	40
163355	3476060016331	0,035	24	76
163555	3476060016355	0,123	12	76
163655	3476060016362	0,123	12	76
163755	3476060016379	0,123	12	76
164055	3476060016409	0,135	12	67
164355	3476060016430	0,14	5	53 87
164555	3476060016454	0,18	5	53 87
164755	3476060016478	0,019	250	40
164955	3476060016492	0,83	5	173
165055	3476060016508	0,101	10	25 26
165255	3476060016522	0,1	5	60
165355	3476060016539	0,104	5	60
165455	3476060016546	0,122	5	60
165555	3476060016553	0,122	5	60
165655	3476060016560	0,133	5	60
165755	3476060016577	0,135	5	60
165855	3476060016584	0,153	5	60
165955	3476060016591	0,101	10	225
166355	3476060016638	0,518	10	65
166755	3476060016676	0,035	72	40
167055	3476060016706	0,128	6	66 93
167955	3476060016799	0,127	6	66 93
168055	3476060016805	0,23	10	37 159
169055	3476060016904	0,125	5	61
169155	3476060016911	0,13	5	61
169255	3476060016928	0,149	5	61
169355	3476060016935	0,2	5	65
169455	3476060016942	0,234	5	65
169555	3476060016959	0,26	25	65
169655	3476060016966	0,28	5	65
169955	3476060016997	0,64	30	73 98
170055	3476060017000	0,454	5	81
170155	3476061701557	0,244	6	41
170255	3476061702554	0,13	12	41
170355	3476061703551	0,09	12	41
170455	3476061704558	0,165	12	41
170655	3476061706552	0,081	12	41
170755	3476061707559	0,247	6	41
171655	3476060017161	0,151	4	68 69 94 95
171755	3476060017178	0,25	4	68 69 94 95
171855	3476060017185	0,37	4	68 69 94 95
171955	3476060017192	0,47	4	68 69 94 95

Ref.	EAN code	Net weight	PCB	Pages
172055	3476060017208	0,7	2	68 69 94 95 175
172155	3476060017215	0,85	2	68 69 94 95 175
172255	3476060017222	1,075	2	68 69 94 95 175
173055	3476060017307	0,955	6	43
174255	3476061742550	0,45	10	42
174355	3476061743557	0,287	10	65
174455	3476061744554	0,354	10	65
175055	3476061750555	0,283	6	19 234
175355	3476061753556	1,31	10	28
175455	3476061754553	0,99	10	28
175555	3476061755550	0,27	12	19 234
175855	3476061758551	0,38	6	19 234
178055	3476061780552	0,027	100	53
178555	3476061785557	1,85	15	49
178655	3476061786554	4,4	6	49
178755	3476061787551	3,80	1	49
178855	3476061788558	3,461	12	49
179555	3476061795556	0,27	48	73 98
179655	3476061796553	0,36	24	73 98
181055	3476061810556	0,11	8	62 90
181155	3476061811553	0,12	8	62 90
181255	3476061812550	0,14	8	62 90
181355	3476061813557	0,14	8	62 90
181455	3476061814554	0,15	8	62 90
181555	3476061815551	0,16	8	62 90
181655	3476061816558	0,13	8	62 90
181755	3476061817555	0,14	8	62 90
181855	3476061818552	0,16	8	62 90
181955	3476061819559	0,18	8	62 90
182055	3476061820555	0,16	8	62 90
182155	3476061821552	0,21	8	62 90
185055	3476061850552	1,2	1	253
185155	3476061851559	0,71	1	253
185255	3476061852556	1,135	1	253
185355	3476061853553	1,385	1	253
185455	3476061854550	1,94	1	253
185555	3476061855557	2	1	253
186055	3476061860551	4,26	1	142 252
186155	3476061861558	2,3	1	142 252
186255	3476061862555	3,15	1	142 252
186355	3476061863552	4,485	1	142 252
186455	3476061864559	5,045	1	142 252
186555	3476061865556	6,27	1	142 252
187055	3476061870550	2,3	1	254
187155	3476061871557	1,01	1	254
188155	3476060018816	0,215	50	142 252
188255	3476060018823	0,725	1	253
188355	3476060018830	0,08	50	253

Ref.	EAN code	Net weight	PCB	Pages
188455	3476060018847	3,25	1	251
188555	3476060018854	1,26	1	251
188955	3476061889552	1,72	1	142 252
189055	3476060018908	0,17	30	251
189155	3476060018915	0,205	30	251
189255	3476060018922	0,2	25	251
189355	3476060018939	0,155	50	251
190000	3476060019004	7,64	1	240 272
199255	3476060019929	0,053	12	41 43 80 107
230155	3476062301558	1,36	5	224
230255	3476062302555	0,937	1	207
231055	3476060023100	0,77	5	190
231155	3476060023117	0,054	100	191
231955	3476060023193	0,17	80	186 255
232055	3476062320559	0,14	100	186 255
232155	3476062321556	0,14	100	186 255
232255	3476062322553	0,16	100	186 255
232655	3476060023261	0,064	100	191
233955	3476062339551	0,52	5	213
234355	3476062343558	0,235	10	219
236455	3476060023643	0,105	20	214
249818	3476062498180	0,653	10	273
249826	3476062498265	0,649	10	273
250155	3476062501552	0,4	10	116
250255	3476062502559	0,76	10	116
250355	3476062503556	1,04	10	116
251001	3476062510011	17,6	1	104
251055	3476062510554	10,52	1	104
251101	3476062511018	23,7	1	104
251155	3476062511551	13,1	1	104
251201	3476062512015	31,3	1	104
251255	3476062512558	16,7	1	104
251355	3476062513555	6,8	1	106
251455	3476062514552	0,11	70	107
251655	3476062516556	0,35	40	107
251755	3476062517553	0,64	1	107
251955	3476062519557	1,22	5	111
252055	3476062520553	2	5	111
252155	3476062521550	0,89	20	113 244
252355	3476062523554	0,06	60	120
252455	3476062524551	0,09	72	120
252555	3476062525558	0,115	60	120
252655	3476062526555	0,1	66	120
252755	3476062527552	0,065	36	120
252855	3476062528559	0,073	36	120
252955	3476062529556	0,09	36	120
253055	3476062530552	0,075	36	120
253155	3476062531559	0,066	50	120
253255	3476062532556	0,077	40	120
253955	3476062539555	0,2	60	120
254055	3476062540551	0,32	5	121 145

Ref.	EAN code	Net weight	PCB	Pages
254155	3476062541558	0,53	5	121 145
254255	3476062542555	0,041	58	128
254355	3476062543552	0,295	30	130
254555	3476062545556	0,41	6	123
254655	3476062546553	0,32	6	130
254755	3476062547550	0,12	12	131
254855	3476062548557	0,45	10	113
254955	3476062549554	0,56	10	113
255055	3476062550550	1,14	6	113
255155	3476062551557	0,17	50	119
255255	3476062552554	0,17	50	119
255355	3476062553551	0,17	50	119
255455	3476062554558	0,17	50	119
255555	3476062555555	0,16	50	119
255655	3476062556552	0,34	30	119
255755	3476062557559	0,34	30	119
255855	3476062558556	0,34	30	119
255955	3476062559553	0,33	30	119
256055	3476062560559	0,16	6	120
256155	3476062561556	0,12	100	127
256255	3476062562553	0,16	80	127
256355	3476062563550	2,64	1	126
256455	3476062564557	0,38	30	127
256555	3476062565554	0,31	10	127
256655	3476062566551	0,3	20	129
256755	3476062567558	0,06	30	129
256855	3476062568555	0,04	30	129
256955	3476062569552	0,08	30	129
257055	3476062570558	0,29	15	128
257155	3476062571555	0,29	15	128
257255	3476062572552	0,78	10	116
257355	3476062573559	4,61	4	114
257455	3476062574556	0,95	1	118
257555	3476062575553	1,5	1	118
257655	3476062576550	0,1	20	118
257755	3476062577557	8,4	1	118
257855	3476062578554	12,8	1	118
257955	3476062579551	23,46	1	118
258055	3476062580557	1,6	8	123
258155	3476062581554	1,7	8	123
258255	3476062582551	1,56	10	123
258355	3476062583558	0,315	28	112
258455	3476062584555	0,024	80	128
258555	3476062585552	2,52	1	103 135
258655	3476062586559	0,34	30	119
258855	3476062588553	1,7	8	123
258955	3476062589550	0,85	16	123
259055	3476062590556	0,86	16	123
259255	3476062592550	1,6	1	122
259355	3476062593557	1,6	1	122
259455	3476062594554	0,35	10	119
259555	3476062595551	0,8	16	123

Ref.	EAN code	Net weight	PCB	Pages
259655	3476062596558	0,9	16	123
259755	3476062597555	0,44	6	102 134
259855	3476062598552	0,88	6	102 134
259955	3476062599559	0,37	30	130
260055	3476060026002	0,35	10	18 178
260155	3476062601559	12,3	1	169 230
260255	3476062602556	2,9	1	50
260355	3476062603553	7,4	1	50
260455	3476060026040	0,034	50	33
260555	3476062605557	0,295	10	27 184 235
260655	3476062606554	0,985	6	81 99 131 147 175 227 247 275
260755	3476062607551	0,35	10	119
261255	3476060026125	0,69	6	52
261855	3476062618557	0,7	5	121 145 257
261955	3476062619554	0,88	5	121 145 257
262055	3476062620550	0,21	50	109 136
262255	3476062622554	0,3	20	120
262355	3476062623551	0,001	12	120
262855	3476060026286	0,05	50	48 144
263955	3476060026392	0,081	12	48
264055	3476062640558	0,055	10	48
265555	3476060026552	0,16	5	60
265655	3476060026569	0,17	5	60
265755	3476060026576	0,17	5	60
265855	3476060026583	0,19	5	60
266055	3476060026606	0,352	10	67
266155	3476060026613	0,35	10	67
266255	3476060026620	0,383	10	67
266355	3476060026637	0,57	6	245
266555	3476060026651	13,25	1	166 167
266655	3476060026668	3,79	1	172 231
266755	3476062667555	0,03	50	161
266855	3476060026682	0,008	50	169 172 230 231
266955	3476060026699	17,16	1	237 167 169 172 230
267155	3476060026712	2,8	10	231
267355	3476060026736	54	1	46 47
267955	3476062679558	3	19	172 231
268155	3476062681551	0,11	5	60
268255	3476062682558	0,12	5	60
268355	3476062683555	0,15	5	60
268455	3476062684552	0,17	5	60
268655	3476062686556	42,5	1	45
269055	3476060026903	1,491	10	115 220 246
269155	3476060026910	0,85	5	144
269455	3476062694551	1	1	117
271555	3476062715553	0,28	4	73 98
272355	3476062723558	0,016	150	110
272455	3476062724555	0,018	150	110
272555	3476062725552	0,02	200	110
272655	3476062726559	0,09	60	110

Ref.	EAN code	Net weight	PCB	Pages
272755	3476062727556	0,1	40	110
272855	3476062728553	0,23	28	110
272955	3476062729550	0,47	15	110
273055	3476062730556	0,77	12	110
273155	3476062731553	0,05	50	110
273255	3476062732550	0,05	50	110
273355	3476062733557	0,05	50	110
273455	3476062734554	0,13	50	110
273555	3476062735551	0,17	50	110
273655	3476062736558	0,28	32	110
273755	3476062737555	0,5	15	110
273855	3476062738552	0,57	10	110
273955	3476062739559	0,6	10	111
274055	3476062740555	1,6	4	74 84
274155	3476062741552	3,3	4	75 85
274255	3476062742559	0,06	100	110
274355	3476062743556	0,12	100	110
274455	3476062744553	0,06	100	110
274555	3476062745550	0,12	100	110
274655	3476062746557	0,167	100	110
274755	3476062747554	0,298	50	110
274855	3476062748551	0,14	10	257
276655	3476062766555	1,6	8	123
276755	3476062767552	0,28	10	54 89
277055	3476062770552	0,13	20	64 92
277155	3476062771559	0,165	20	64 92
277255	3476062772556	0,176	12	64 92
277355	3476062773553	0,205	12	64 92
277455	3476062774550	0,213	15	64 92
277555	3476062775557	0,245	12	64 92
277655	3476062776554	0,265	15	64 92
277755	3476062777551	0,275	8	64 92
277855	3476062778558	0,25	12	86
277955	3476062779555	0,28	6	86
278055	3476062780551	0,48	5	58
278155	3476062781558	0,4	5	58
278255	3476062782555	0,34	12	64 92
280055	3476062800556	1	10	18 179
280155	3476062801553	0,49	20	18 179
280255	3476062802550	0,8	10	18 61
281055	3476062810555	0,55	15	125
281155	3476062811552	0,59	15	125
281255	3476062812559	0,57	15	125
281355	3476062813556	0,59	15	125
281455	3476062814553	0,61	15	125
281555	3476062815550	0,61	15	125
281655	3476062816557	0,65	15	125
281755	3476062817554	0,7	15	125
281855	3476062818551	0,65	15	125
281955	3476062819558	0,65	20	125
282055	3476062820554	0,25	1	124
282155	3476062821551	0,92	1	124

Ref.	EAN code	Net weight	PCB	Pages			
283055	3476062830553	0,853	1	54	88	112	142
				174	180	243	250
283155	3476062831550	0,029	10	185	234		
283255	3476062832557	0,024	10	185	234		
283355	3476062833554	0,024	10	185	234		
283455	3476062834551	2,6	1	123			
283555	3476062835558	2,48	1	123			
289955	3476060028990	11,6	1	141			
290255	3476060029027	0,76	10	236			
290355	3476062903554	0,7	10	244			
366255	3476060036629	1,7	5	159			
366355	3476060036636	0,082	100	159			
366655	3476060036667	3	1	168			
366755	3476060036674	0,654	1	160			
366855	3476060036681	0,007	50	167			
366955	3476060036698	14	1	158			
367155	3476063671551	16,8	1	164	165		
367455	3476063674552	0,019	50	165			
367555	3476063675559	0,78	1	160			
367655	3476063676556	2,71	5	238	239		
367755	3476063677553	2,676	5	238	239		
367855	3476063678550	8,109	3	239			
367955	3476063679557	1,18	6	56	57		
368155	3476063681550	31	1	162	163		
368301	3476063683011	16,65	1	156	157		
368355	3476063683554	16,65	1	156	157		
368401	3476063684018	1,5	1	170	171	232	233
368455	3476063684551	1,25	1	170	171	232	233
368555	3476063685558	59	1	156	157		
368655	3476063686555	14	1	152	153		
368755	3476063687552	2,5	1	154	155		
369055	3476063690552	1,8	6	115	220	246	
371655	3476063716559	0,16	4	68	69	94	95
371755	3476063717556	0,29	4	68	69	94	95
371855	3476063718553	0,412	4	68	69	94	95
371955	3476063719550	0,52	4	68	69	94	95
372055	3476063720556	0,7	2	68	69	94	95
				175			
372155	3476063721553	0,954	2	68	69	94	95
				175			
372255	3476063722550	1,18	2	68	69	94	95
				175			
466455	3476060046642	0,071	15	161			
466555	3476060046659	0,052	15	161			
466655	3476060046666	0,26	6	161			
466755	3476060046673	0,042	50	161			
466855	3476060046680	0,01	50	168			
466955	3476064669557	0,26	25	161			
503550	3476065035504	0,24	20	188			
506292	3476065062920	0,022	100	43			
506583	3476065065839	0,878	10				

Ref.	EAN code	Net weight	PCB	Pages			
523100	3476065231005	0	100	191			
523101	3476065231012	0	100	191			
525100	3476065251003	0,022	100	105	106		
525101	3476065251010	0,87	5	105			
525104	3476065251041	1	20	105			
525105	3476065251058	1,2	20	105			
525109	3476065251096	1,15	1	105			
525470	3476065254707	0,1	100	131			
526652	3476065266526	0,272	2	167			
526665	3476065266656	0,721	1	165	167	169	172
526666	3476065266663	1,285	1	165	167	169	230
526667	3476065266670	1,214	1	165	167		
526793	3476065267936	0,333	10	165	167	169	172
527781	3476065277812	0,05	50	86			
527782	3476065277829	0,006	100	86			
527791	3476065277911	0,086	30	86			
528300	3476065283004	0,15	1	54	88	112	142
				174	180	243	250
536621	3476065366219	0,165	5	159			
536622	3476065366226	0,165	5	159			
536671	3476065366714	0,83	30	161			
536711	3476065367117	1,52	1	165			
536712	3476065367124	0,51	10	165			
536750	3476065367506	0,045	50	161			
536760	3476065367605	0,29	10	239			
536761	3476065367612	0,4	4	239			
536807	3476065368077	2,75	5	238	239		
536808	3476065368084	1,7	5	238	239		
536823	3476065368237	0	100	163			
536824	3476065368244	0	100	163			
536825	3476065368251	1,589	5	163			
536826	3476065368268	0,356	6	163			
536830	3476065368305	0	100	157			
536831	3476065368312	0,35	5	157	163	168	171
				233			
536832	3476065368329	0,4	10	155	157	163	168
				171	233		
536840	3476065368404	1,271	4	157	163	168	171
				233			
536841	3476065368411	0,008	50	171	233		
536843	3476065368435	0,753	12	155	157	163	168
				171	233		
536850	3476065368503	0,013	100	157			
536860	3476065368602	0,5	30	153			
536861	3476065368619	0,5	30	153			
536862	3476065368626	0,5	30	153			
536864	3476065368640	0,5	20	153			
536865	3476065368657	0,08	40	153			
536881	3476065368817	0,45	5	155			
536887	3476065368879	0,19	15	155			
536888	3476065368886	0,32	30	155			
536889	3476065368893	0,40	50	155			



Ref.	EAN code	Net weight	PCB	Pages	
536890	3476065368909	1,179	50	239	
536891	3476065368916	0,185	20	239	
536892	3476065368923	0,24	15	155	
536893	3476065368930	0,008	100	155	
536894	3476065368947	0,009	50	155	
536895	3476065368954	0,008	100	155	
536896	3476065368961	0,009	50	155	
536897	3476065368978	0,002	20	155	
536898	3476065368985	0,04	20	155	
546690	3476065466902	0,02	50	161	
564055	3476065640555	0,007	100	48	
564255	3476065642559	0,045	20	184	
566855	3476060056689	0,035	100	32	
610160	3476066101604	1,7	5	61	
610161	3476066101611	1,75	5	63	91
610190	3476066101901	3,4	1	70	96
610191	3476066101918	8,3	1	71	97
743006	3476067430062	2,05	1	16	
743021	3476067430215	6,3	1	105	
743022	3476067430222	8,3	1	105	
743023	3476067430239	11,6	1	105	
743032	3476067430321	2,63	1	17	
743035	3476067430352	0,85	10	16	72 99
743036	3476067430369	2,5	1	16	72 99
900460	3476060004604	0,907	20	268	
900461	3476060004611	0,895	20	268	
900463	3476069004636	0,74	20	268	
900466	3476069004667	1,829	8	268	
900470	3476060004703	0,784	20	266	
900480	3476060004802	1,829	8	266	
960447	3476069604478	6,1	1	242	
960449	3476060004499	1,353	1	241	
960452	3476060004529	1,193	1	241	270
960453	3476060004536	5,95	1	241	
960457	3476060004574	1,315	1	241	
960458	3476060004581	1,695	1	241	
960459	3476060004598	6,895	1	241	
960491	3476060004918	1,99	1	270	
961449	3476060014498	3,795	1	241	
961459	3476069614590	3,895	1	241	
961480	3476060014801	1,593	1	241	
962449	3476060024497	1,55	1	241	
962458	3476069624582	4,245	1	241	
963453	3476060034533	1,793	1	241	



## HEADQUARTERS

Actiparc Pierre Maurel  
214 Avenue Pierre Maurel  
83480 Puget-sur-Argens  
France

Tel. : +33 (0)4 94 44 70 70

Website : [www.edma.fr](http://www.edma.fr)

Email : [contactedma@edma.fr](mailto:contactedma@edma.fr)

## COPYRIGHTS

© All rights reserved - 2024.

## PHOTO CREDIT

EDMA, ADOBE STOCK

EDMA company, whose headquarters are located at Actiparc Pierre Maurel, 214 Avenue Pierre Maurel, 83480 Puget-sur-Argens, with a capital of 2 007 320 €, is registered at Registre du Commerce et des Sociétés of Fréjus, under No 480 074 327.

EDMA general catalogue presents non contractual pictures and a content subject to omissions or typographical errors.

The descriptive elements of the products such as dimensions, weight or colour are presented for information only and have no contractual value. Any difference between these descriptive statements and the delivered product cannot be the subject of claims on this sole and exclusive basis. Suggestions for presentation.

EDMA reserves the right to modify the articles presented without prior notice in order to improve their technical or aesthetic specifications.

Do not throw on the public road.

Reproduction of the present document, even partial, is prohibited.

